

InfoServer

System Operations Guide

Order Number: AA-PJXJC-TE

October 1994

This document explains how to manage an InfoServer system.

Revision/Update Information: This document supersedes the *InfoServer System Operations Guide* for Version 3.0.

Software Version: InfoServer Software Version 3.2

**Digital Equipment Corporation
Maynard, Massachusetts**

First Edition, October 1990
Second Edition, October 1991
Third Edition, April 1993
Fourth Edition, October 1994

Digital Equipment Corporation makes no representations that the use of its products in the manner described in this publication will not infringe on existing or future patent rights, nor do the descriptions contained in this publication imply the granting of licenses to make, use, or sell equipment or software in accordance with the description.

Possession, use, or copying of the software described in this publication is authorized only pursuant to a valid written license from Digital or an authorized sublicensor.

© Digital Equipment Corporation 1994. All rights reserved.

The postpaid Reader's Comments forms at the end of this document request your critical evaluation to assist in preparing future documentation.

The following are trademarks of Digital Equipment Corporation: DEC, DECnet, DECserver, Digital, InfoServer, LASTport, LAT, OpenVMS, PATHWORKS, RRD42, RZ, ULTRIX, VAX, VAX DOCUMENT, VT100, and the DIGITAL logo.

Apple and Macintosh are registered trademarks of Apple Computer, Inc.

MS-DOS is a registered trademark of Microsoft Corporation.

PostScript is a registered trademark of Adobe Systems Incorporated.

This document is available on CD-ROM.

This document was prepared using VAX DOCUMENT Version 2.1.

Contents

Preface	ix
1 Server Description	
1.1 InfoServer Functions	1-1
1.2 Server/Client Relationship	1-3
1.3 Automatic Service Policies and Availability Features	1-4
1.4 Establishing an InfoServer Management Session	1-4
1.5 InfoServer Command Summary	1-6
1.6 InfoServer Help Facility	1-7
2 Server Features and Functions	
2.1 LASTport Protocols	2-1
2.1.1 LASTport Protocol	2-2
2.1.2 LASTport/Disk Protocol	2-2
2.1.3 LASTport/Tape Protocol	2-3
2.2 Automatic Mounting of Compact Discs	2-3
2.3 Installation of Functional Upgrades from Compact Discs	2-4
2.4 Internal Read/Write Device Functions	2-4
2.4.1 Partitions	2-4
2.4.2 Serving an Entire Disk to the Network	2-5
2.5 Tape Functions	2-6
2.6 X Terminal Clients	2-6
2.7 Service Ratings	2-7
2.8 InfoServer Naming Conventions	2-8
2.8.1 InfoServer Name	2-8
2.8.2 Service Names	2-9
2.8.3 Partition Names	2-9
2.8.4 Device Names	2-10
2.9 Service Classes	2-11
2.10 InfoServer Read/Write-Access Policies	2-12
2.11 MOP Functions	2-13

2.11.1	MOP Identify Self Message	2-13
2.11.2	MOP Request Counters Message	2-13
2.11.3	MOP Loop Messages	2-13
2.11.4	MOP Downline Loading	2-13

3 Server Management Commands

3.1	Command Syntax Conventions	3-1
3.1.1	Wildcard Matching	3-1
3.1.2	Special Keys	3-2
3.2	InfoServer Commands	3-2
	BACKUP	3-4
	BIND	3-6
	CLEAR	3-7
	COPY	3-8
	CRASH	3-10
	CREATE PARTITION	3-11
	CREATE SERVICE	3-13
	DELETE PARTITION	3-17
	DELETE SERVICE	3-18
	DISCONNECT	3-20
	ERASE	3-21
	EXIT	3-22
	HELP	3-23
	INITIALIZE	3-24
	LOOP	3-25
	MONITOR	3-26
	PURGE VXT	3-27
	REBOOT	3-28
	RECORD	3-29
	RESTORE	3-31
	RETRIEVE	3-33
	REWIND	3-34
	SAVE	3-35
	SET DEVICE	3-37
	SET PARTITION	3-38
	SET SERVER AUTOMOUNT	3-39
	SET SERVER CACHE BUCKETSIZE	3-40

SET SERVER CACHE SIZE	3-41
SET SERVER CRASHDUMP	3-42
SET SERVER EXTENSION	3-44
SET SERVER GROUP	3-45
SET SERVER IDENTIFICATION	3-47
SET SERVER LASTPORT GROUP	3-48
SET SERVER LAT_RESPONDER	3-49
SET SERVER MOP	3-50
SET SERVER MULTICAST	3-52
SET SERVER NAME	3-53
SET SERVER PASSWORD	3-54
SET SERVER PROMPT	3-55
SET SERVER REMOTE	3-56
SET SERVER STATE	3-58
SET SERVER WRITE ACCESS	3-59
SET SERVICE	3-60
SHOW DEVICE	3-63
SHOW ETHERNET	3-66
SHOW FUNCTIONS	3-71
SHOW LAST	3-72
SHOW LAT	3-73
SHOW MOP	3-78
SHOW PARTITIONS	3-82
SHOW SERVER	3-85
SHOW SERVICE	3-91
SHOW TAPE	3-96
UNBIND	3-99
UNLOAD	3-100
UPDATE FUNCTIONS	3-101
UPDATE SYSTEM	3-102
UPDATE VXT	3-106
VERIFY	3-107
ZERO ALL	3-108
ZERO ETHERNET	3-109
ZERO LAT	3-110
ZERO MOP	3-111
ZERO SERVER	3-112

4 Advanced Operations

4.1	Serving Regularly Updated Compact Discs	4-2
4.2	Assigning Passwords to Protect Compact Discs	4-3
4.3	Serving Media Under Several Names	4-3
4.4	Creating and Serving Partitions	4-4
4.5	Serving an External Read/Write Disk	4-5
4.6	Backing Up Read/Write Data	4-6
4.6.1	Backing Up Data Locally	4-6
4.6.2	Backing Up Data Remotely	4-7
4.7	Defragmenting an InfoServer Disk	4-8
4.8	Replicating an InfoServer Disk	4-9
4.9	Making Downline Loadable Images Available to Clients	4-10
4.9.1	MOP Downline Loading by Ethernet Address	4-11
4.9.2	Automatic Installation of MOP Partitions	4-12
4.10	Configuring X terminals	4-12
4.11	Enforcing Network License Limits for Devices	4-14
4.12	Compact Disc Recorder (CD-R) Function	4-14
4.12.1	Component Setup	4-15
4.12.2	Recording Procedures	4-16
4.13	Performing Network Installations and Updates	4-18
4.13.1	Connecting to a Remote Service	4-18
4.13.2	Performing Updates Using a Remote Service	4-19
4.13.3	Disconnecting from a Remote Service	4-19
4.13.4	Restrictions	4-19

5 Troubleshooting

5.1	Client System Cannot Connect to InfoServer Device	5-1
5.2	Access to InfoServer Devices Seems Slow	5-8
5.3	Cannot Enter InfoServer Commands from a Local Console	5-9
5.4	Cannot Enter InfoServer Commands from a Remote Console	5-11
5.5	InfoServer Software Does Not Boot	5-16
5.6	Online Help No Longer Available	5-19
5.7	InfoServer System Does Not Boot Completely	5-19
5.8	InfoServer System Does Not Downline Load Clients	5-21
5.9	InfoServer Password Forgotten	5-26

A Server Command Syntax Summary

B Server Messages

B.1	Informational Messages	B-2
B.2	Error Messages	B-3
B.3	Warning Messages	B-8

Index

Figures

1-1	InfoServer System Serving Clients	1-3
4-1	Recording Configuration	4-15

Tables

1-1	InfoServer Command Set	1-6
2-1	DKn: Devices	2-10
3-1	InfoServer Special Keys	3-2
3-2	Valid Class Names	3-14
3-3	SHOW DEVICE Display Fields	3-64
3-4	SHOW ETHERNET Display Fields	3-67
3-5	SHOW LAT COUNTERS Display Fields	3-74
3-6	SHOW LAT SESSIONS Display Fields	3-77
3-7	SHOW MOP Display Fields	3-79
3-8	SHOW PARTITIONS Display Fields	3-84
3-9	Fields Common to All SHOW SERVER Displays	3-87
3-10	SHOW SERVER CHARACTERISTICS Display Fields	3-87
3-11	SHOW SERVER COUNTERS Display Fields	3-88
3-12	SHOW SERVER STATISTICS Display Fields	3-89
3-13	SHOW SERVICE Display Fields	3-93
3-14	SHOW TAPE Display Fields	3-97
5-1	InfoServer Boot Flag Bits	5-17

Preface

Document Purpose

This document explains how to manage an InfoServer system. You can use the InfoServer commands described in Chapter 3 to set up services for client systems in your local area network (LAN). The document also provides troubleshooting information to help you solve problems that affect InfoServer operations.

For information on installing and troubleshooting InfoServer hardware, refer to the following documents:

InfoServer 100 Installation and Owner's Guide
InfoServer 150 Installation and Owner's Guide
InfoServer 1000 Installation and Owner's Guide

For information on managing InfoServer devices on client systems, see the InfoServer client documents for those systems.

Intended Audience

This document is intended for InfoServer managers.

Document Structure

This document contains five chapters and two appendixes.

- Chapter 1, "Server Description," provides an overview of the InfoServer system and explains how to establish an InfoServer management session.
- Chapter 2, "Server Features and Functions," describes InfoServer facilities, such as automatic mounting of compact discs, device-naming conventions to simplify access, and downline-loading capabilities.
- Chapter 3, "Server Management Commands," describes InfoServer commands, including format, parameters, and examples.

- Chapter 4, “Advanced Operations,” describes operations for setting up customized configurations and provides examples.
- Chapter 5, “Troubleshooting,” provides information to identify and solve common operating problems.
- Appendix A, “Server Command Syntax Summary,” provides a quick-reference summary of the command syntax for each InfoServer command.
- Appendix B, “Server Messages,” lists and describes informational, error, and warning messages.

Related Documents

You can order the following InfoServer hardware documents from Digital. Not all documents are available in every country. Check with your Digital sales representative for availability.

Title	Order Number
<i>InfoServer 100 Installation and Owner's Guide</i>	EK-DIS1K-IN-001
<i>InfoServer 150 Installation and Owner's Guide</i>	EK-INFSV-OM-001
<i>InfoServer 1000 Installation and Owner's Guide</i>	EK-INFLC-OM-001

Conventions

The following conventions are used in this document:

Ctrl/x

A sequence such as Ctrl/x indicates that you must hold down the key labeled Ctrl while you press another key or a pointing device button.

Return

In examples, a key name is shown enclosed in a box to indicate that you press a key on the keyboard. (In text, a key name is not enclosed in a box.)

.
.
.

A vertical ellipsis indicates the omission of items from a code example or command format; the items are omitted because they are not important to the topic being discussed.

()

In format descriptions, parentheses indicate that, if you choose more than one option, you must enclose the choices in parentheses.

{ ... | ... }

In format descriptions, choices between two or more options are enclosed in braces ({ }). Choices are separated by a vertical bar (|).

[]

In format descriptions, brackets indicate that whatever is enclosed within the brackets is optional; you can select none, one, or all of the choices. (Brackets are not, however, optional in the syntax of a directory name in a file specification or in the syntax of a substring specification in an assignment statement.)

boldface text

Boldface text represents the introduction of a new term or a phrase that is emphasized in text.

Boldface text is also used to show user input in command examples.

italic text

Italic text represents information that can vary (for example, *device*).

UPPERCASE TEXT

Uppercase letters indicate that you must enter a command (for example, enter **SHOW SERVER**), or they indicate the name of a file, the name of a file protection code, or the abbreviation for a system privilege.

numbers

Unless otherwise noted, all numbers in the text are assumed to be decimal. Nondecimal radices—binary, octal, or hexadecimal—are explicitly indicated.

Server Description

The InfoServer system is a high-performance, **virtual device server**. It can serve physical device media and sets of logical disk blocks to client systems in a local area network (LAN). Systems running the appropriate client software can connect to virtual devices served by the InfoServer system and use them as though they are locally attached devices.

Unlike a **file server**, the InfoServer system does not impose a file system on the virtual devices that it serves. The InfoServer system can serve compact discs and read/write disks with any type of on-disk structure. Because client systems interpret the on-disk structure, each client can use its own native file system. Multiple on-disk structures can be served by and accessed on a single InfoServer system at the same time.

This chapter discusses the following topics:

- InfoServer functions
- Server/client relationship
- Automatic service policies and availability features
- Establishing an InfoServer management session
- InfoServer command summary
- InfoServer Help facility

1.1 InfoServer Functions

The InfoServer system can perform the following functions:

- **Serve compact discs to network clients.**

The InfoServer system serves compact discs automatically, using the volume label as the service name when the server is booted, or when compact discs are inserted in InfoServer drives. Some client systems (for example, OpenVMS and ULTRIX) simply bind to and mount the compact discs under their volume labels.

Server Description

1.1 InfoServer Functions

The InfoServer system can automatically serve to clients compact discs that are in Apple hierarchical file system (HFS), Files-11 On-Disk Structure Level 2 (ODS-2), High Sierra Group (HSG), ISO 9660, or ULTRIX File System (UFS) format. other media types can be served manually through the InfoServer management interface.

- **Serve Small Computer System Interface (SCSI) tapes.**

The InfoServer system can serve SCSI tape devices to network clients by using service names. Client systems can connect to these tape devices and utilize them as though they are locally attached devices.

- **Serve read/write disk partitions.**

A **partition** is a logical subset of a read/write disk. A single disk can be subdivided into several partitions, each of which can be served to the network independently. To remote client systems, these partitions appear to be whole disks. For example, an OpenVMS client can access InfoServer partitions and use them as though they are local hard disks.

- **Act as an initial load system for OpenVMS systems.**

The InfoServer system can downline load the primary bootstrap program to OpenVMS systems by responding to maintenance operation protocol (MOP) requests. The server can locate MOP downline load files on the OpenVMS software distribution compact disc and copy them into temporary MOP partitions on an InfoServer-formatted read/write disk.

The ISL bootstrap program connects back to the software distribution compact disc and boots Standalone Backup. The Backup utility is then used to copy the OpenVMS operating system save sets from the compact disc to a read/write disk attached to the system. All subsequent OpenVMS boots are done from the local read/write disk.

- **Downline load other products.**

You can use the InfoServer system to load any Ethernet product by file name; that is, the server does not require a Network Control Program (NCP) database entry to locate the requested file. For example, X terminal clients use the InfoServer system to downline load their system software. You can create a special MOP partition and copy the desired file to that partition. The server additionally supports downline loading of services by Ethernet address. Each InfoServer system can handle up to 100 simultaneous downline loads more efficiently than host-based downline loaders, which must start processes to assist in the load.

1.2 Server/Client Relationship

Figure 1-1 shows the relationship of the InfoServer system to several client systems. In this figure, two compact discs and two hard disks connected to the server appear to the client systems as local devices. The VAX and RISC clients might be accessing software distribution and online documentation files on one or two of the compact discs, while the Macintosh client might be updating data on an InfoServer disk partition. The X terminal boots from the InfoServer system and uses InfoServer disks for page, font, and customization files.

Figure 1-1 InfoServer System Serving Clients

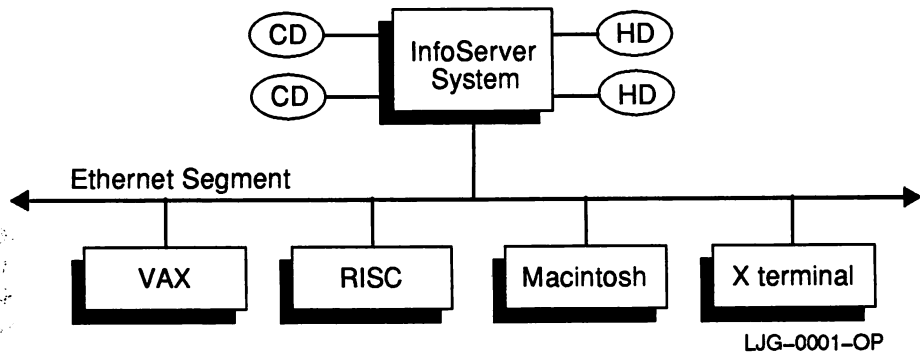

You can simply connect the InfoServer system to your LAN and turn the server on. After the server is initialized, or **bootstrapped**, the server software automatically makes available, or **serves**, to client systems the media connected to it. For example, if you insert a compact disc into a server drive, the server detects this new disc and automatically serves it to client systems by using the volume label as the service name.

The server bootstraps from its internal read/write device, on which the InfoServer software is preinstalled. InfoServer software updates are distributed on compact discs. As these new releases become available, you can install the software onto the internal device for subsequent booting.

You might want to customize InfoServer functions such as automounting of specific devices. You can control server functions by logging in to the server and entering server commands, described in Chapter 3.

1.3 Automatic Service Policies and Availability Features

The InfoServer system automatically serves compact discs to clients when the server is first turned on or when a disc is inserted in a drive. The server reads the volume label and uses the label as the name of the service offered to clients.

Note

You can use the **SET SERVER AUTOMOUNT** command to disable the serverwide automount function. You can use the **SET DEVICE AUTOMOUNT** command to disable automount for individual devices, such as compact discs, that are not in InfoServer format.

If multiple servers offer the same services, the client uses a rating scheme to select the best service (see Section 2.7). When duplicate read-only devices are available under identical service names, the client balances the load among the devices.

If you remove a compact disc from a server drive, the InfoServer system ends all client connections to the associated service. The server also stops offering, or **unservices**, the associated service to client systems.

However, when a read-only service is interrupted (for example, the server reboots, or a compact disc is removed from a drive), the client attempts to reconnect to the service. If a duplicate read-only service is offered elsewhere on the LAN, the client automatically connects to the duplicate volume. File operations continue as normal, and users experience almost no service disruption.

1.4 Establishing an InfoServer Management Session

The server manager can establish a server management session from a local or remote console terminal as follows:

- **For a local session**, connect a terminal capable of interpreting VT100 ANSI escape sequences to the serial port on the rear of the InfoServer system unit.

Note

This terminal must be set to 9600 baud, 8 bits, no parity.

Server Description

1.4 Establishing an InfoServer Management Session

- **For a remote session**, make a connection to the InfoServer system through a LAT terminal server.

Like many host systems, the InfoServer system advertises a LAT terminal server service for its management interface and accepts connections from remote terminals attached to terminal servers. Therefore, any terminal attached to a terminal server on the extended LAN can act as a console terminal for the InfoServer system (if the user knows the InfoServer management password).

Determining the Server's Default Service Name

To make a remote connection to the InfoServer system for the first time, you must first determine the server's default name. To do this, add the 4-character prefix LAD_ to the hexadecimal Ethernet data link address on the system's enclosure (see the installation and owner's guide for your unit). You can change this default name by using the command SET SERVER NAME (see Chapter 3).

The server's name is the service name to which you connect. For example, if the default server name is LAD_08002B15009F, then you would enter the following command at the terminal server's prompt to manage the InfoServer system:

```
Local> CONNECT LAD_08002B15009F
```

Note

See your terminal server user's guide to learn more about the establishment of LAT terminal server service connections.

Entering an InfoServer Password

After you connect to the InfoServer system, you must enter an InfoServer password. The default server password is ESS. You can change the password with the SET SERVER PASSWORD command (see Chapter 3).

Sample Session

The following example shows how to establish a session from a terminal server:

```
Local> CONNECT LAD_08002B133C1C
Password: ESS (not echoed)
Local -010- Session 1 to LAD_08002B133C1C established
```

```
DEC InfoServer 1000 V3.2
```

```
InfoServer>
```

Server Description

1.4 Establishing an InfoServer Management Session

In this example, the terminal server's prompt is `Local>`, and a LAT terminal server session is established to the InfoServer system whose service name is `LAD_08002B133C1C`. The server prompts you to enter a password. When you enter the correct password, the server displays the `InfoServer>` prompt.

Ending a Session

At the end of the management session, you can exit by entering `EXIT` at the `InfoServer>` prompt. This action returns you to the terminal server's `Local>` prompt if the management session is over a LAT terminal server connection.

1.5 InfoServer Command Summary

Table 1–1 summarizes InfoServer management commands, which are described in detail in Chapter 3.

Table 1–1 InfoServer Command Set

Command	Function
BACKUP	Saves InfoServer-formatted disks.
BIND	Establishes a connection to the specified ODS-2 service and creates the virtual device VDK1 for that service.
CLEAR	Erases the console terminal screen.
COPY	Copies data from one disk or partition to another.
CRASH	Causes the server software to take a recognizable bugcheck, creating a dump if crashdump processing is enabled.
CREATE	Creates a new partition or service.
DELETE	Deletes a partition or service that was previously created.
DISCONNECT	Disconnects a LASTport or LAT terminal server session.
ERASE	Erases the specified disk or partition, or FUNCTIONS or SERVICES data if the device is nonvolatile random-access memory (NVRAM).
EXIT	Terminates the management session.
HELP	Displays help text for InfoServer commands.
INITIALIZE	Formats a read/write disk into an InfoServer-formatted disk.
LOOP	Automatically repeats any valid InfoServer command.

(continued on next page)

Table 1–1 (Cont.) InfoServer Command Set

Command	Function
MONITOR	Automatically repeats any valid InfoServer command every 3 seconds, clearing the screen and placing the cursor at the home position.
PURGE VXT	Purges old versions of VXT software.
REBOOT	Shuts down and reboots the server.
RECORD	Records data from an InfoServer disk or partition to a writable compact disc.
RESTORE	Resets the server to a previously saved system configuration.
RETRIEVE	Restores InfoServer-formatted disks saved by the BACKUP command.
REWIND	Rewinds an InfoServer tape.
SAVE	Saves configuration and service data for recovery after a server reboot.
SET	Sets device, partition, service, or server parameters.
SHOW	Displays the server's parameters and counters.
UNBIND	Deletes the VDK1 virtual device and terminates the connection to the remote service.
UNLOAD	Rewinds and unloads an InfoServer tape.
UPDATE	Installs one or more new software products or functions.
VERIFY	Validates the on-disk structure of a device formatted with the INITIALIZE command.
ZERO	Sets internal server counters to 0.

1.6 InfoServer Help Facility

The InfoServer system provides a Help facility that contains information about each server command, including parameters, options, and examples of its use. See the HELP command description in Chapter 3 for more information about the Help facility.

Server Features and Functions

This chapter provides information on the following topics:

- LASTport protocols
- Automatic mounting of compact discs
- Installation of functional upgrades from compact discs
- Tape functions
- X terminal clients
- Service ratings
- Naming conventions
- Service classes
- Read/write-access policies
- Maintenance operation protocol (MOP) functions

2.1 LASTport Protocols

The InfoServer system uses the LASTport transport and the LASTport/Disk and LASTport/Tape system application protocols to provide access to the virtual devices it serves to the local area network (LAN). These protocols provide high-performance access to disk and tape devices in an extended LAN. The InfoServer system implements the server portion of the protocols, while the client systems that access InfoServer devices implement the client portion.

Server Features and Functions

2.1 LASTport Protocols

2.1.1 LASTport Protocol

The LASTport protocol is a specialized transport protocol that allows many clients to access InfoServer systems and perform reliable transactions. For the InfoServer system, a transaction is a device read or write operation. The LASTport protocol allows various client systems to read and write information concurrently to an InfoServer device.

Unlike timer-based protocols, the LASTport protocol is a transaction-oriented protocol. Normally, information does not pass between a client and an InfoServer system unless the client initiates a transaction. The client system then runs a timer on the transaction, normally waiting from 2 to 5 seconds before assuming that the transaction was lost and retrying the operation.

The LASTport protocol does not provide any routing functions; it runs only in a LAN network. The LASTport protocol type is 80-41. If the extended LAN uses any filtering devices, they must allow this protocol type to pass unfiltered so that clients can access InfoServer systems across the filtering device.

The InfoServer system uses a multicast address feature of the LASTport protocol to establish connections to devices. The format of the multicast address is 09-00-2B-04-*nn-*nn**, where *nn* depends on the LASTport group enabled (see the description of the SET SERVER LASTPORT GROUP command in Chapter 3).

2.1.2 LASTport/Disk Protocol

The LASTport/Disk protocol is a specialized disk protocol that uses the LASTport transport. That is, LASTport/Disk messages are delivered in LASTport messages. The LASTport/Disk protocol provides the mechanism for reading and writing logical disk blocks independent from any underlying file system. The clients that implement the LASTport/Disk protocol interpret the file system locally. By using the LASTport/Disk protocol for disk access, the InfoServer system can support multiple operating systems and disk file structures concurrently.

The LASTport/Disk protocol also provides the naming facility to access disks. The InfoServer system assigns each virtual disk a name. The LASTport/Disk protocol allows clients to query the LAN for service names. When the requested service is found, the client connects to it, and disk access can begin. When duplicate virtual devices are available under duplicate service names, the LASTport/Disk protocol provides a facility for load balancing among the available devices (see Section 2.7).

2.1.3 LASTport/Tape Protocol

Like the LASTport/Disk protocol, the LASTport/Tape protocol uses the LASTport transport. That is, LASTport/Tape messages are delivered in LASTport messages. The LASTport/Tape protocol provides the mechanism for reading and writing tape records. Tape devices attached to the InfoServer system appear to tape clients as locally attached devices.

The LASTport/Tape protocol also provides the naming facility to access tapes. The InfoServer system assigns each tape device a name. The LASTport/Tape protocol allows clients to query the LAN network for service names. When the requested service is found, the client connects to it, and tape access can begin.

2.2 Automatic Mounting of Compact Discs

The InfoServer system can automatically recognize newly installed devices that are in the following formats:

- Apple hierarchical file system (HFS)
- Files-11 On-Disk Structure Level 2 (ODS-2)
- High Sierra Group (HSG)
- ISO 9660
- ULTRIX File System (UFS)

The server reads the volume label and makes that volume label name available to the LAN as a service name. This process is called the **automount** feature. You can use the `SET SERVER AUTOMOUNT` command to enable or disable the automount feature serverwide, and you can enable or disable automounting for specific devices with the `SET DEVICE AUTOMOUNT` command (see Chapter 3).

With the automount feature enabled, you do not need to enter any InfoServer management commands to access compact discs. The InfoServer system automatically makes the compact discs available to client systems. Client systems simply use their native access method to connect to the volume label name.

The InfoServer system automatically serves any compact discs that are present when the InfoServer system boots. It also detects and serves new compact discs that are inserted while the system is running. If a volume is removed while the system is running, the system deletes the volume label service, and any client connections to the volume are broken. If the same volume is reinserted, client connections are reestablished. If a different volume is reinserted, it is automatically served with its own volume label.

Server Features and Functions

2.2 Automatic Mounting of Compact Discs

If you do not know the volume label of a compact disc or tape, you can use the InfoServer management interface to determine it. After inserting the volume, enter the `SHOW DEVICE` command at the `InfoServer>` prompt. This display lists the volume labels for all volumes on the system. See the description of the `SHOW SERVICE` command in Chapter 3.

2.3 Installation of Functional Upgrades from Compact Discs

InfoServer software enables installation of functional upgrades from Function compact discs. As new functions become available, customers can purchase separately and install each function that they want to make available on the LAN. See the description of the `UPDATE FUNCTIONS` command in Chapter 3.

2.4 Internal Read/Write Device Functions

The InfoServer 1000 system includes internal `FLASH` memory that stores the system image and help text. The `FLASH ROM` (read-only memory) is preinitialized and loaded with the InfoServer operational software. Server configuration information is stored in `NVRAM` (nonvolatile random access memory).

The InfoServer 150 system comes with an internal read/write disk. The InfoServer software uses this disk to store InfoServer parameters, characteristics, and other information specific to the InfoServer system. This internal disk is preinitialized and loaded with the InfoServer operational software.

2.4.1 Partitions

Normally, any InfoServer disk (a disk that has been initialized with the InfoServer `INITIALIZE` command) is not served to the LAN network as a whole disk. Instead, logical subdisks called **partitions** are served to the LAN network. A single InfoServer disk can be subdivided into several smaller partitions. Each partition can be treated as a whole disk by remote clients. Because partitions do not overlap, different systems can use different partitions without conflict.

InfoServer software automatically creates several partitions that are formatted with different file systems and are reserved for use by the system itself. Normally, the partitions (whose names are also reserved) are created on the internal device. The subsections that follow describe these partitions.

BOOT_PARTITION Partition

The **BOOT_PARTITION** partition is factory installed on the internal device and contains the bootable InfoServer kernel as well as online help information. This partition cannot be deleted, nor should it ever be served to the network, because OpenVMS clients might crash when attempting a connection.

CONFIGURATION Partition

The **CONFIGURATION** partition is created or updated whenever the InfoServer **SAVE** command is issued. This partition contains InfoServer characteristics such as the server name, password, and identification string. The partition is read whenever the server reboots, or when the **RESTORE** command is issued.

2NDARY_CONFIGURATION Partition

The **2NDARY_CONFIGURATION** partition is created or updated whenever a remote client such as an X terminal requests creation of a partition and service name. Remotely created service names are saved separately from those created locally so that remote operations do not inadvertently save temporary local operations. Only information for remotely created services is saved in this partition.

IS_FUNCTIONS Partition

The **IS_FUNCTIONS** partition is created whenever Function compact discs are installed on the InfoServer system. All installed functions are saved in this partition so that they can be restored when the InfoServer system reboots. You can reconstruct this partition from Function compact discs if it is lost. You might also want to create another copy of the partition (using the InfoServer **COPY** command) under a different partition name.

2.4.2 Serving an Entire Disk to the Network

In some situations, when you might want to serve an entire InfoServer disk to the LAN. For example, you might want to make a backup of the InfoServer disk on a remote client system. The remote client system should access the disk as if the on-disk structure were unknown, because the disk is in InfoServer format. Under the OpenVMS operating system you would use a **MOUNT/FOREIGN** command. Note that you should never serve an InfoServer-formatted disk for write access. See Section 4.6 for an example of backing up InfoServer disks.

2.5 Tape Functions

The InfoServer system can serve Small Computer System Interface (SCSI) tape devices to the network using service names. Client systems can connect to these tape devices and utilize them as though they are locally attached devices.

InfoServer clients can share tape devices. However, while many clients can access an InfoServer compact disc simultaneously, only one client at a time can access a tape device. When a client is finished using a tape device, the client disconnects. Other clients can then use the device. Each client views the remote tape device as though it were locally attached.

2.6 X Terminal Clients

X terminal clients use the InfoServer system to downline load their system software, provide font services, save configuration information, and page memory to and from InfoServer disks. X terminal system files can be installed on the InfoServer system from compact disc. Once installed, this system software is downline loaded on demand to each X terminal client when it is turned on.

X terminal clients can dynamically allocate partitions on an InfoServer disk as needed. For example, when an X terminal user requests that terminal customizations be saved, the InfoServer system automatically creates a disk partition to hold the information and creates a network service name for that partition. Once customization information is saved, the X terminal client can recall the information at any time.

Certain X terminals that are InfoServer clients can also be virtual memory machines. Such virtual memory X terminals (VXTs) can page sections of main memory to and from disks as required. Because a VXT client has no local disk, it uses InfoServer disks as page disks. When main memory needs to be paged out to disk, the VXT client requests the InfoServer system to create a partition. This partition is then automatically extended as needed. Partitions and their network service names are created dynamically, without the need for any user action.

By default, the InfoServer disk DK1, which is the internal read/write disk that ships with InfoServer 100 and 150 systems, is enabled to allow X terminal clients to allocate partitions remotely. Other disks can also be enabled through the use of InfoServer commands. InfoServer 1000 systems require an external read/write disk to provide paging services for X terminal clients.

2.7 Service Ratings

The InfoServer system provides static load balancing across duplicate media within an extended LAN. To do this, the InfoServer system provides a **rating** for every service that it offers. When duplicate services are available, client systems select the service with the highest rating. A higher rating indicates a more readily available service for client connections; a lower rating indicates lower availability.

By default, the InfoServer system dynamically calculates a rating based on the InfoServer load for each service. The dynamic rating for each device service is calculated and updated every 10 seconds. The following algorithm is used to calculate the dynamic rating for services, within the range of 0 to 65535:

$$\text{Rating} = (32768 * \%CPU_FREE) + (32767 * ((0.9 * \textit{last_calc_srvd_load}) + (0.1 * \textit{new_calc_srvd_load})))$$

The first term, called the server load factor, is an instantaneous look at the CPU percentage, weighted over one-half the rating scale.

The seconds term, called the service load factor, is 90 percent of the last calculated load factor plus 10 percent of the current calculated load factor, weighted over one-half the rating scale. The LASTport load factor is then replaced with the current calculation of the service load factor. This calculation produces a moving weighted average that is calculated at each timer interval, for each service. The formula for the *new_calc_srvd_load* term is as follows:

$$\textit{new_calc_srvd_load} = \frac{1000 - \min(1000, \textit{I/Os to service in last 10 sec})}{1000}$$

As a result, a load is imposed on the service based on the number of block reads in the past 10 seconds. The term *last_calc_srvd_load* is then updated with the new service load factor calculated.

Any service that is blocked by a write session to an overlapping virtual disk is assigned a rating of 0. See Section 2.10 for more information on concurrent read/write-access.

The following algorithm is used to calculate the dynamic rating for tapes, within the LASTport/Tape protocol range of 0 to 65535:

$$\text{Rating} = (32768 * \%CPU_FREE) + (32767 * \%POOL_FREE)$$

Any tape service that has maximum connections receives a rating of 0.

2.8 InfoServer Naming Conventions

The InfoServer system manages several different resources by using their assigned names. For example, services, logical disk partitions, and devices have assigned names. Assigning names to resources makes it easier to access and manage them. Individual resources have different policies that govern the names applied to those resources.

2.8.1 InfoServer Name

The InfoServer system itself is assigned a name. Each InfoServer name must be unique within an extended LAN. The InfoServer name identifies the InfoServer unit. This name is also used as a LAT management service that is advertised to the LAN network.

When the InfoServer system is shipped, the InfoServer software assigns each InfoServer unit a unique name. The default name is in the form LAD_XXXXXXXXXXXX, where XXXXXXXXXXXX is the hexadecimal ASCII representation of the InfoServer system's Ethernet adapter address. An example is LAD_08002B15009F. The maximum length of the name is 16 characters.

If you choose, you can change the InfoServer name to a name that is more meaningful for your particular environment. If you assign an InfoServer name, you must use the following sets of characters:

- A–Z
- a–z
- 0–9
- \$ (dollar sign)
- . (period)
- _ (underscore)
- - (hyphen)
- Multinational characters in the ASCII range 192 through 255

All InfoServer names are case-insensitive. For example, the InfoServer system would treat an uppercase A and lowercase a as a match.

2.8.2 Service Names

The InfoServer system can assign service names to devices and partitions. These service names are the access mechanism for remote client nodes. Clients specify the names of services to which they want to connect. The InfoServer system resolves the names down to the requested virtual device and then completes the connection request.

Service names offered by the InfoServer system are restricted to the same set of characters used for InfoServer unit names (see Section 2.8.1).

Note that some compact discs might have volume labels that contain characters other than those listed in Section 2.8.1. In that case, the InfoServer system substitutes underscore (_) characters. If a compact disc does not have a volume label, you must create a service manually. See the description of the CREATE SERVICE command in Chapter 3.

Because identical media or data can be made available on the extended LAN concurrently, it is possible to have duplicate service names. A service name might be available more than once on a single InfoServer system or might be available on more than one InfoServer system. When redundant service names are available, clients use load balancing to select the least busy media. If one service should fail, clients automatically attempt to connect to any available duplicate service.

2.8.3 Partition Names

The InfoServer system can create sets of logical blocks, called **partitions**, on read/write media. A partition is a subset of a physical read/write device that can be served to the LAN as though the partition were an entire disk. When the InfoServer system creates a partition on behalf of a remote client, a partition name must be supplied as part of the CREATE SERVICE command.

Partition names are local to the InfoServer system and are not visible to remote client systems. Clients gain access to partitions through the use of service names. The partition names are used only by the InfoServer command set for ease of management. Partition names are unique within a single read/write device.

Partition names created by the InfoServer system are restricted to the same set of characters used for InfoServer server names (see Section 2.8.1) and contain the reserved character “#”.

Server Features and Functions

2.8 InfoServer Naming Conventions

2.8.4 Device Names

The InfoServer 1000 system can support up to seven SCSI devices on its single external SCSI bus, designated as SCSI-A.

The InfoServer 150 system can support up to 14 SCSI devices. The system has two buses designated as SCSI-A and SCSI-B, each of which can support up to seven devices. SCSI-A is an internal bus that has a compact disc drive and a read/write drive preconfigured into the system. SCSI-B is an external bus that may have a second compact disc drive preconfigured into the system, depending on your InfoServer model. You can add external disk and magnetic tape devices to the SCSI-B bus.

Each device on each bus is assigned a number from 0 to 7 that is set by switches on the device. The InfoServer system assigns a device name to each device of the form DK*n*: (TP*n*: for magnetic tapes), where *n* is a device number greater than or equal to 0. Device numbers are assigned in ascending order, starting with 0. The numbering starts with the SCSI devices on SCSI-A and continues with SCSI-B for the InfoServer 100 and 150 systems. Table 2-1 lists the range of DK*n*: devices available to the system.

Table 2-1 DK*n*: Devices

SCSI-A Unit	InfoServer 100 Device	InfoServer 150 Device InfoServer 1000 Device ¹	Device Name
0	Unused	Available for expansion	DK0
1	Preconfigured read/write disk	Preconfigured read/write disk Available for expansion ²	DK1
2	Preconfigured compact disc	Preconfigured compact disc Available for expansion ²	DK2
3	Unused	Available for expansion	DK3
4	Unused	Available for expansion	DK4
5	Unused	Available for expansion	DK5
6	CPU bus position	CPU bus position	Reserved
7	Unused	Available for expansion	DK7

¹The InfoServer 1000 has a single SCSI bus.

²Available for expansion on the InfoServer 1000 system.

(continued on next page)

Table 2-1 (Cont.) DK*n*: Devices

SCSI-B Unit	InfoServer 100 Device	InfoServer 150 Device	Device Name
0	Available for expansion	Available for expansion	DK8
1	Available for expansion	Available for expansion	DK9
2	Available for expansion	Available for expansion	DK10
3	Available for expansion	Available for expansion	DK11
4	Available for expansion	Available for expansion	DK12
5	Preconfigured or available	Available for expansion	DK13
6	CPU bus position	CPU bus position	Reserved
7	Available for expansion	Available for expansion	DK15

2.9 Service Classes

Because the InfoServer system is a virtual disk server rather than a file server, it can support multiple operating systems and multiple on-disk file structures concurrently. The InfoServer system provides a means for logically subdividing the services offered on the LAN network into groups that are meaningful to each client system. These logical subdivisions are based on **service classes**.

A service class divides the individual virtual disks that the InfoServer system offers to the LAN into different namespaces. Each client system accesses only the namespaces that are meaningful to it. For example, OpenVMS systems access services that are offered under the ODS_2 namespace, while ULTRIX systems access services under the ULTRIX, High Sierra Group (HSG), and ISO 9660 namespaces. Because each client sees only the services in its own namespace, an OpenVMS client can never accidentally connect to an ULTRIX disk.

When it automounts a new compact disc, the InfoServer system creates a service under the service class that is appropriate for the disk structure found on the compact disc. For example, if the InfoServer system reads the volume label from an ISO 9600 compact disc, it creates a service with the volume label as the name under the ISO 9600 service class.

The InfoServer system can automatically serve compact discs that are in Apple HFS, High Sierra Group, ISO 9660, ODS-2, and ULTRIX UFS formats. You can use InfoServer commands to serve other media types under any of the supported service classes. Chapter 3 describes the available service classes and the InfoServer commands.

2.10 InfoServer Read/Write-Access Policies

The InfoServer system is a virtual disk server. Because it does not impose an underlying file structure on the disks it serves, the InfoServer system does not provide a locking mechanism to prevent concurrent write-access to the same sets of disk blocks. Instead, the InfoServer system enforces a connection policy that prevents such conflicts that could result in data corruption.

You can select one of two policies:

- **Pre-emptive.** By default, the InfoServer system allows write-access to a virtual disk only after all other read access has been disconnected. For example, a LAN write-access connection would immediately disconnect all read access connections that conflict with the write-access request, then allow write access after all readers are disconnected. Readers are blocked from reconnecting to those same disk blocks for the duration of the write-access connection.

This type of policy is ideally suited for classes of data that are infrequently updated, but frequently read. Readers are prevented from reading bad data while the write-access connection updates the data. After the write-access connection is terminated, the readers reconnect to the updated data.

- **Blocking.** Instead of immediately disconnecting any read-only connections, the write-access connection is delayed until all read connections are disconnected voluntarily by the remote clients.

This policy is ideally suited for information that must be highly available for read access, but may be updated during off hours.

For either policy, the InfoServer system prevents concurrent access during write operations. This local locking policy guarantees data integrity.

Note that because partitions do not overlap on an InfoServer disk, write access to one partition does not prevent read or write access to a different partition on the same device. Locking occurs only for requests to the same partition, or to the same disk volume.

For more information on setting the InfoServer write access policy, see the SET SERVER WRITE ACCESS command description in Chapter 3.

2.11 MOP Functions

The InfoServer system implements several features of the maintenance operation protocol (MOP) of the DECnet Digital Network Architecture. The following sections describe supported features.

2.11.1 MOP Identify Self Message

The InfoServer system responds to MOP “request identity” messages with a MOP “system identification” message to the requesting node.

The InfoServer system also broadcasts a system identification periodically to the LAN and responds with its system virtual address (SVA) as the communication device type.

2.11.2 MOP Request Counters Message

The InfoServer system responds to MOP “request counters” messages with a MOP “counters” message to the requesting node.

2.11.3 MOP Loop Messages

The InfoServer system responds to MOP “loop direct” and MOP “loop assist” messages by returning the loop data as directed in the received loop request. For example, on an OpenVMS system, you can test Ethernet connectivity with the InfoServer system by using the DECnet NCP command LOOP CIRCUIT; from a terminal server, you can use the terminal server’s TEST LOOP command.

2.11.4 MOP Downline Loading

The InfoServer system can be configured to act as a MOP downline load server. This means that the InfoServer system can receive downline load requests and then downline load the requesting system, if the requested load image is present. You can enable or disable this feature for individual InfoServer systems by using the command SET SERVER MOP. You can enable or disable the feature for specific devices by using the command SET DEVICE MOP SEARCH. (See Chapter 3).

The InfoServer system can handle up to 100 concurrent downline loads. Unlike host-based downline load servers that must start processes to assist in the loading process, the InfoServer system can handle downline load requests quickly and efficiently. The InfoServer system can provide an ideal solution for LAN conditions that cause many systems to request a downline load at the same time, such as after a power failure in a terminal server LAN network.

Server Features and Functions

2.11 MOP Functions

When the InfoServer system receives a load request that it can possibly service, it searches for the following:

- 1 A matching service name in the MOP service class
- 2 On InfoServer-formatted disks, a MOP partition with a matching partition name
- 3 In the directory [SYS0.SYSEXEXE] on ODS-2 format disks, a matching file name with the .SYS file type.

MOP partitions are special partitions that can be downline loaded. For information on installing MOP partitions for downline loading, see Section 4.9.

Server Management Commands

This chapter describes the InfoServer management commands and provides examples of their use.

3.1 Command Syntax Conventions

The following conventions apply to the commands in this chapter:

Convention	Meaning
UPPERCASE	Words in uppercase indicate a command or command option that you enter as shown.
Lowercase	Words in lowercase indicate parameters that you specify.
[]	Optional choices are enclosed in brackets ([]).
{ }	Choices between two or more options are enclosed in braces ({ }). Choices are separated by a vertical bar ().
PRE-EMPTIVE (D)	A (D) indicates the default setting for a command option when there is a choice of two or more option settings.

3.1.1 Wildcard Matching

Some InfoServer commands allow wildcard operations. If you use a wildcard string in an InfoServer command, then all objects matching the wildcard string are used in the specified operation.

The InfoServer system uses two wildcard characters:

- * Matches any number of any characters in the current character position.
- % Matches exactly one character in the current character position.

For example, suppose you entered the following command:

```
InfoServer> SHOW SERVICE AB%DE*
```

Server Management Commands





3.1 Command Syntax Conventions

The InfoServer system would select all services whose names start with the letters AB, followed by any one character, followed by the letters DE, followed by any number of any characters.

3.1.2 Special Keys

The InfoServer management console reserves certain keyboard keys for special functions. Table 3–1 lists the reserved keys that the InfoServer console uses and the function that each key provides.

Table 3–1 InfoServer Special Keys

Key	Function
	Deletes the previous character in the current command line.
	Ends the current command line and executes the command.
	Recalls the last InfoServer command executed. The InfoServer system saves the last 10 commands executed at the console.
	Deletes all characters in the current command line.
	Displays “Exit” in reverse video, ends the command line, and terminates the InfoServer session.

3.2 InfoServer Commands

This chapter describes the following commands:

BACKUP
BIND
CLEAR
COPY
CRASH
CREATE
DELETE
DISCONNECT
ERASE
EXIT
HELP
INITIALIZE
LOOP
MONITOR
PURGE VXT

Server Management Commands

3.2 InfoServer Commands

REBOOT
RECORD
RESTORE
RETRIEVE
REWIND
SAVE
SET
SHOW
UNBIND
UNLOAD
UPDATE
VERIFY
ZERO

BACKUP

BACKUP

Backs up InfoServer-formatted disks. You use the **RETRIEVE** command to restore the disks.

Format

```
BACKUP src_device[:] dest_device[:]
```

Parameters

src_device[:]

Specifies the source device, which must be a valid InfoServer-formatted disk, as defined in Table 2-1.

dest_device[:]

Specifies the destination device, which must be a valid InfoServer-formatted disk, as defined in Table 2-1.

Description

The **BACKUP** command copies all partitions from an InfoServer-formatted disk to the destination disk. The destination disk is initialized in InfoServer format, and the partitions are copied along with additional information to identify the disk as a backup copy. (The **SHOW PARTITIONS** command identifies the device as a backup device.) In addition, service information about the partitions copied is also saved to the destination disk.

Unlike the **COPY** function, the **BACKUP** function can be performed between devices of different sizes. If all partitions do not fit on the destination device, InfoServer software displays warning messages while the backup operation continues. In addition, the **BACKUP** command performs disk compression, allocating partitions contiguously and defragmenting InfoServer-formatted disks during **BACKUP** and **RETRIEVE** operations.

To preserve data integrity, InfoServer software does not permit **BACKUP** operations unless the InfoServer state is set **OFF**. This check prevents remote virtual disk operations from interfering with local disk operations. (See the description of the **SET SERVER STATE** command.) In addition, the **BACKUP** command locks both the source and destination devices against local disk operations for the duration of the **BACKUP** operation.

**Example**

```
InfoServer> SET SERVER STATE OFF  
InfoServer> BACKUP DK1 DK15  
InfoServer> RETRIEVE DK15 DK1  
InfoServer> SET SERVER STATE ON  
InfoServer> SAVE
```

These commands back up the data on the system disk DK1 to the DK15 disk and defragment the DK1 disk.

BIND

BIND

Connects to an ODS-2 compact disc service on another InfoServer system on the local area network (LAN) and creates the virtual device VDK1.

Format

```
BIND ODS-2-service-name [PASSWORD optional-password ]
```

Parameters

ODS-2-service-name

Specifies the ODS-2 service name of a compact disc attached to another InfoServer system on the LAN.

PASSWORD *optional-password*

Optionally specifies a password to access the service.

Description

The BIND command connects to an ODS-2 class service on a remote InfoServer system and creates the read-only virtual device VDK1, which you can use as the source device for network installations and updates. All update operations (FUNCTION, MOP, SYSTEM, and VXT) are supported using the BIND, UNBIND, and UPDATE commands. (The UNBIND and UPDATE commands are described in this chapter; for detailed information on performing network installations and updates, refer to Section 4.13.)

Example

```
InfoServer> BIND UPD_DRV PASSWORD RAINMAN
%ESS-I-VDCREATE, Virtual device VDK1: successfully created.
%ESS-I-VDCONN, VDK1: connected to service: UPD_DRV
```

```
InfoServer> SHOW DEVICE VDK1:
```

Device Name	Device State	Device Type	Device Address	Dev. Size/ Record Num.	Volume Label	Device Char
VDK1:	On	Virtual Disk	N/A	962	UPD_DRV	RO

The BIND command connects to the service UPD_DRV, associates the password RAINMAN with the service, and creates the virtual device VDK1. The SHOW DEVICE command then displays the characteristics of the device.

CLEAR

Clears the screen of a video terminal capable of interpreting VT100 ANSI escape sequences.

Format

CLEAR

Description

The CLEAR command erases the screen of a terminal that is capable of receiving VT100 ANSI escape sequences.

Example

```
InfoServer> CLEAR
```

The terminal screen is erased as soon as you press the Return key.

1
2
3
4
5

COPY

Copies data from one disk or partition to another disk or partition.

Format

```
COPY src_device[:partition] dest_device[:partition]
```

Parameters

src_device[:partition]

Specifies the source device or partition. The device must be a valid InfoServer disk device, as defined in Table 2-1.

The partition must already exist on the specified device. If you do not specify a partition, the entire disk is copied.

dest_device[:partition]

Specifies the destination device or partition. The device must be a valid InfoServer disk device, as defined in Table 2-1.

If you do not specify a partition name, the entire disk is copied. If you specify a partition name that does not exist, the system creates the destination partition.

Description

You use the COPY command to make copies of data from one InfoServer disk or partition to another disk or partition. The *src_device[:partition]* parameter specifies the source of the copy. The *dest_device[:partition]* parameter specifies the destination of the copy. For the copy to complete successfully, the size of the source and destination must be the same.

To preserve data integrity, the InfoServer system does not allow copy operations unless you have set the InfoServer state to OFF. This operation prevents remote virtual disk operations and local disk operations from interfering with each other. For more information, see the description of the SET SERVER STATE command.

A copy operation blocks all other local operations to the source and destination devices. This action ensures that local users do not corrupt data by copying the data to the same disk partitions. Copy operations to tapes are not allowed.

Example

```
InfoServer> COPY DK1:MY_PARTITION DK11:SAVE_PARTITION
%ESS-I-CREATED, Create partition completed successfully.
%ESS-I-COPIED, Copy operation completed successfully.
```

This command copies the data from a partition named MY_PARTITION on the DK1 disk to a partition named SAVE_PARTITION on the DK11 disk. The message following the command indicates that DK11:SAVE_PARTITION did not exist. The InfoServer system created it and continued with the copy operation.

CRASH

CRASH

Causes the server software to take a recognizable machine check, creating a dump if crash dump processing is enabled.

Format

CRASH [YES]

Description

Use the CRASH command if you are requested to produce a dump for analysis by Digital support personnel. The CRASH command prompts for confirmation.

Example

```
InfoServer> CRASH
```

```
_Are you sure you want to force a crash of the server now [No]?
```

If you answer Y or YES, this command creates an InfoServer crash dump if crash dump processing is enabled. (See the description of the SET SERVER CRASHDUMP command.)

CREATE PARTITION

Creates a partition on a writable disk.

Format

```
CREATE PARTITION device:partition [BLOCKS | BYTES | MEGABYTES] value [options]
```

Parameters

device:partition

Specifies a valid InfoServer disk device, as defined in Table 2–1. Tape devices are not partitioned.

The partition must not already exist on the specified device.

value

Specifies the size of the partition to be created in blocks, bytes, or megabytes. One block is equal to 512 bytes of disk storage. Bytes are rounded up to the nearest block size.

Options

MOP DISABLED (D)

Specifies that the partition not be used to contain an image file that the InfoServer system can downline load using the maintenance operation protocol (MOP) (see Section 2.11). MOP DISABLED is the default if the option is omitted.

MOP ENABLED

Specifies that the partition can be used to contain an image file that the InfoServer system can downline load using MOP. The InfoServer system downline loads images only from partitions that have MOP enabled.

ERASE

Writes an erase pattern on the allocated blocks. The erase algorithm is a single-pass write of zeros.

CREATE PARTITION

Description

You use the **CREATE PARTITION** command to create a partition on a writable disk. Partitions are a subset of logical blocks that can be served to the local area network (LAN) as a whole disk. The size of the partition might be larger than the number of specified blocks if the InfoServer system reuses a previously deleted partition or optimizes the partition size for its own internal disk structure.

See the **SHOW PARTITIONS** command for information on specified and actual sizes.

Example

```
InfoServer> CREATE PARTITION DK1:VIRTUAL_DISK BLOCKS 1024 MOP DISABLED  
%ESS-I-CREATED, Create partition completed successfully.
```

This command creates a partition named **VIRTUAL_DISK** with 1024 blocks on the **DK1** disk and with **MOP** disabled.

CREATE SERVICE

Creates a service name for an entire disk device, a disk partition, or an entire tape device.

Format

```
CREATE SERVICE service-name [FOR] device[:partition] [options]
```

Parameters

service-name

Specifies the name to which client systems can bind to access this virtual device service. Service names are restricted to the characters listed in Section 2.8.1.

device[:partition]

The specified device can be either of the following:

- **DK n :**
Specifies a valid InfoServer disk device, as defined in Table 2–1. If you do not supply a partition name, the service is created for the entire disk. If you do supply a partition name, the service is bound to the partition on the disk. The partition must already exist on the disk.
- **TP n :**
Specifies a valid InfoServer tape device, as defined in Table 2–1.

Options

CLASS *class-name*

Specifies the namespace in which this service name exists. Various client systems use different namespaces for different on-disk structures. Namespaces are partitioned so that clients see only the names that are meaningful to them. Classes also allow two services to use the same name without conflict.

If a device being served contains data in a known format, the default service class matches the on-disk structure. For example, if you use the CREATE SERVICE command to create a service for an Apple compact disc and do not specify the service class, the service is created under the APPLE namespace. If the InfoServer system does not recognize a device's on-disk structure, the service is created in the ODS_2 namespace.

CREATE SERVICE

The class name used depends on the client systems that connect to the service being created. For example, OpenVMS systems use the ODS_2 namespace by default when attempting to mount an InfoServer device. Table 3-2 lists valid *class-name* parameter values.

Table 3-2 Valid Class Names

Class	Description
APPLE	Apple hierarchical or flat volumes
HIGH_SIERRA	High Sierra Group (HSG) compact discs
ISO_9660	ISO 9660 compact disc format
MOP	MOP partitions—all other options are ignored for MOP partitions
MSDOS	MS-DOS virtual devices
ODS_2	OpenVMS virtual devices
TAPE	Magnetic tape
ULTRIX	ULTRIX virtual devices
UNFORMATTED	Virtual device that has no format
V2.0	Names understood by MS-DOS clients (PATHWORKS compatibility)
VXT_CONFIGURATION	X terminal configuration information
VXT_PAGEFILE	X terminal page file service
VXT_SYSTEM	X terminal system information
VXT_WORKGROUP	X terminal work group service

Default names are ODS_2 (if a DK device is specified) and TAPE (if a TP device is specified).

DYNAMIC_RATING

Specifies that the InfoServer system should calculate a rating for this service dynamically. This is the default method for service ratings.

[NO]PASSWORD *string*

Specifies an optional access control password for the service. The password string can be up to 39 alphanumeric ASCII characters in length. After you set a password, a client must specify the password to access the service. If you do not specify a password in this command, then clients are not required to provide a password to access the service.

You can enter the password without having it echoed on the screen by entering the `PASSWORD` option as the last option in the `CREATE SERVICE` command. After entering the keyword `PASSWORD`, press Return. The InfoServer system prompts you for the password.

[NO]READERS *number*

Specifies the maximum number of client connections allowed for read access. A value of 0 indicates write-only access, as qualified by the `WRITERS` option, if present. If a client requests read-only access or read/write access to the service, one reader is counted against this number.

Default: 1000 readers

[NO]WRITERS *number*

Specifies the maximum number of client connections allowed for write access. A value of 0 indicates read-only access, as qualified by the `READERS` option, if present. If a client requests write-only access, one writer is counted against this number. If a client requests read/write access to the service, one writer and one reader are counted.

Default: 1 for read/write media, 0 for compact discs

Note

The InfoServer system does not allow more than one writer to connect to a read/write service at one time. See the `SET SERVER WRITE ACCESS` command for more information on the write-access policies described in Section 2.10.

STATIC_RATING *rating*

Specifies a rating from 0 to 65535, used for load balancing across redundant services. Clients always choose a higher rating over a lower one. If you omit the `STATIC_RATING` option, the InfoServer system calculates a dynamic rating based on InfoServer load. Note that if a writer is connected to a service, the rating is not changed until the writer disconnects.

CREATE SERVICE

Description

The **CREATE SERVICE** command creates a service that represents either an entire disk or a partition on a disk.

Note

When you turn on the InfoServer system or insert a compact disc while the server is on, the InfoServer software automatically tries to serve the disk. The InfoServer system uses the volume label as the service name, along with the default parameters specified in the **CREATE SERVICE** command. You can disable this feature with the **SET SERVER AUTOMOUNT** or **SET DEVICE** command.

Examples

1. InfoServer> **CREATE SERVICE ONLINE_DOC FOR DK2:
CLASS ODS 2 PASSWORD NEWCD NOWRITERS**
%ESS-I-CREATED, Create service completed successfully.

This command tells the server to create a service named **ONLINE_DOC** that is password protected with the password **NEWCD**. The service is associated with device **DK2** and is write protected by the **NOWRITERS** option.

2. InfoServer> **CREATE SERVICE BACKUP FOR TP8: CLASS TAPE
PASSWORD BCKUP4 WRITERS 1**
%ESS-I-CREATED, Create service completed successfully.

This command tells the server to create a service named **BACKUP** that is password protected with the password **BCKUP4**. This service is associated with device **TP8** and allows one writer.

DELETE PARTITION

Deletes an existing partition.

Format

```
DELETE PARTITION device:partition [ERASE]
```

Parameter

device:partition

Specifies a valid InfoServer disk device, as defined in Table 2-1. Tape devices are not partitioned.

The partition must already exist on the specified device. Wildcard characters are permitted in partition names.

Option

ERASE

Writes an erase pattern on the allocated blocks. The erase algorithm is a single-pass write of zeros.

Description

You use the **DELETE** command to delete a partition that has been previously created. If the partition has been served to the network, the services bound to the partition are also deleted.

The InfoServer system prompts you for confirmation if you try to delete a partition to which remote clients are currently connected.

Deleted partitions are marked, and then reused when new partitions are created. You can use the **SHOW PARTITIONS** command with the **FULL** option to display all the deleted partitions on a disk.

Example

```
InfoServer> DELETE PARTITION DK1:VIRTUAL_DISK  
%ESS-I-DELETED, Delete partition completed successfully. DK1:VIRTUAL_DISK
```

This command deletes the partition named **VIRTUAL_DISK** on disk **DK1** and makes the space available for reuse.

DELETE SERVICE

Causes the InfoServer system to stop providing the specified service to clients.

Format

```
DELETE SERVICE service-name [FOR] device[:partition] [CLASS class-name]
```

Parameters

service-name

Specifies the name of the service to delete. Usually, a service name is the same as the volume label of the disk volume. The service name can contain wildcard characters.

device[:partition]

The specified device can be either of the following:

- **DK*n***:
Specifies a valid InfoServer disk device, as defined in Table 2–1. If you supply a partition name, only services pointing to the specified partition are deleted.
- **TP*n***:
Specifies a valid InfoServer tape device, as defined in Table 2–1.

As an option, you can add the device, or device and partition, to the **DELETE SERVICE** command. Because an InfoServer system might have two disk volumes with the same service name, the **DELETE** command lets you qualify which service you want to delete. If you omit this parameter, the InfoServer system searches and deletes all service names that satisfy the other qualifiers.

CLASS *class-name*

Specifies the namespace from which the service should be removed. Because each namespace can have the same service name, the **CLASS** parameter indicates which services to delete. If you omit this parameter, the InfoServer system searches and deletes all service names in all classes that satisfy all other parameters. Table 3–2 lists valid *class-name* parameter values.

Description

The **DELETE SERVICE** command deletes an existing service from the InfoServer system. Client systems can no longer access devices or partitions under the deleted service name.

The **DELETE SERVICE** command lets you delete all instances of a service name or a particular service name qualified by device and class name. You can use the *device[:partition]* and **CLASS** parameters to specify the exact service name you want to delete. If you want to delete all instances of a service name, then omit these parameters.

The **DELETE SERVICE** command warns you if clients are connected to the specified service name. You have the option to delete the service (terminating the sessions connected) or to abort the **DELETE SERVICE** command.

Example

```
InfoServer> DELETE SERVICE CD_DOC_00661 FOR DK11: CLASS ODS_2
Warning: 5 users are connected to CD_DOC_00661
Do you still want to delete CD_DOC_00661 [NO]? YES
%ESS-I-DELETED, Delete service request completed successfully.
```

This command returns a warning because the specified service name has client systems connected to it. You are asked if the service should still be deleted. In this example, the answer is YES, so the remote users are disconnected from this service.

DISCONNECT

DISCONNECT

Terminates an existing LASTport or LAT terminal server session.

Format

```
DISCONNECT {LAST | LAT} session-number
```

Parameter

session-number

Specifies the number of a LASTport or LAT terminal server session.

Options

LAST

Specifies a LASTport session.

LAT

Specifies a LAT terminal server session.

Description

The DISCONNECT command immediately breaks an existing connection to the server. Each InfoServer LASTport or LAT terminal server session has a unique session number, which you can display by entering the InfoServer commands SHOW LAST or SHOW LAT. When you enter the DISCONNECT command, you specify the session number of the session you want to disconnect. If you omit the LAST or LAT keyword, LAST is assumed.

Example

```
InfoServer> DISCONNECT LAT 12  
%ESS-I-DISCONNECTED, Session 12 disconnected
```

This command disconnects LAT terminal server session 12.

ERASE

Erases the specified disk or partition, or, if the device is NVRAM (nonvolatile random-access memory), **FUNCTIONS** or **SERVICES** data.

Format

ERASE *device[:partition]* (**FUNCTIONS** | **SERVICES**)

Parameter

device[:partition]

Specifies the read/write disk, disk partition, or NVRAM.

Options

FUNCTIONS

If the device is NVRAM, specifies that **FUNCTIONS** data be erased.

SERVICES

If the device is NVRAM, specifies that **SERVICES** data be erased.

Description

Use the **ERASE** command to erase the following:

- A read/write disk or partition
- **FUNCTIONS** or **SERVICES** data in NVRAM

For disk operations, the server state must be set **OFF** to execute the **ERASE** command. The erase algorithm is a single-pass write of zeros.

Example

```
InfoServer> ERASE NVRAM SERVICES
%ESS-I-ERASE, Erase operation completed successfully.
```

This command erases **SERVICES** data on NVRAM.

EXIT

EXIT

Terminates the InfoServer management session.

Format

EXIT [LOGOUT]

Description

You use the **EXIT** command to log out of the InfoServer system and terminate the InfoServer management session after all management functions are complete. On the console terminal, you are prompted for the login password again before you can enter more commands. On a remote LAT terminal server management terminal, the LAT terminal server session is disconnected. The **LOGOUT** command is functionally equivalent to **EXIT**.

Example

```
InfoServer> EXIT
```

This command ends the current server management session.

HELP

Provides online help information for using the InfoServer management commands.

Format

HELP [*topic*] [*subtopic...*]

Parameters

[*topic*] [*subtopic...*]

You use the HELP command to obtain online help for any of the InfoServer commands. You can specify the *topic* and *subtopic* for which you want help. If you do not specify a *topic*, the system displays a list of topics and prompts you for a selection.

Description

The HELP command is an online reference for InfoServer commands. After you view an initial help display, press Return. The help display stops and the InfoServer> prompt is displayed.

If you do not specify a command name, the HELP command displays general information on the commands for which help is available. If you specify a command name, you obtain syntax information for that command. If you enter the HELP command with a command name only, such as HELP SHOW, the InfoServer system displays a list of all of the command keywords used with the SHOW command.

Example

```
InfoServer> HELP SHOW
```

This command displays a description of the SHOW command and the command format.

INITIALIZE

INITIALIZE

Formats a read/write disk into an InfoServer disk.

Format

```
INITIALIZE device[:]
```

Parameter

device[:]

Specifies a valid InfoServer disk device, as defined in Table 2-1. Tape, FLASH memory, and NVRAM (nonvolatile random-access memory) devices cannot be initialized.

Description

Use the INITIALIZE command to format a read/write disk into an InfoServer disk capable of supporting partitions or storing system configuration information. Initializing a disk destroys any data already stored on the disk. Before entering an INITIALIZE command, you must issue a SET SERVER STATE OFF command.

By default, the single read/write disk preconfigured with the InfoServer system is already initialized.

Example

```
InfoServer> SET SERVER STATE OFF
InfoServer> INITIALIZE DK4:
%ESS-I-INIT, Initialize completed successfully.
InfoServer> SET SERVER STATE ON
```

This command initializes the DK4 disk.

Note

When you initialize an InfoServer device, any data on the device is lost. This includes any configuration information that might have been saved previously.

LOOP

Automatically repeats any valid InfoServer command.

Format

LOOP [*server-command*]

Parameter

server-command

Specifies a valid InfoServer command. If you do not specify a command, the InfoServer system prompts you for the command.

Description

You use the LOOP command to repeat any valid InfoServer command. The LOOP command continues to repeat the specified command until you press any key.

Example

```
InfoServer> LOOP SHOW SERVICE
```

This command repeats the SHOW SERVICE command automatically.

MONITOR

MONITOR

Repeats any valid InfoServer command every 3 seconds.

Format

MONITOR [*server-command*]

Parameter

server-command

Specifies a valid InfoServer command. If you do not specify a command, the InfoServer system prompts you for the command.

Description

You use the MONITOR command to repeat any valid InfoServer command. The MONITOR command pauses for 3 seconds between commands and moves the cursor to the home position on ANSI-type screens. This action makes the command useful for redisplaying SHOW command screens.

To stop the MONITOR command, press any key.

Example

```
InfoServer> MONITOR SHOW ETHERNET
```

This command repeats the SHOW ETHERNET command every 3 seconds, refreshing the screen for each display.

PURGE VXT

Purges previous versions of VXT files from the specified destination disk.

Format

```
PURGE VXT src_device[:] [dest_device[:] ]
```

Parameters

src_device[:]

Specifies the drive containing the VXT distribution compact disc.

dest_device[:]

Optionally specifies the destination device to which the new VXT files were copied and from which older VXT files are to be purged.

If you omit the destination device name, the InfoServer system uses, in order, one of the following:

- 1 The device from which the system booted, if the device is writable
- 2 The InfoServer-formatted device with the lowest device number

Description

If you decide not to purge old X terminal files during an UPDATE VXT operation, you can use the PURGE VXT command to do so later.

Example

```
InfoServer> PURGE VXT DK2: DK1:  
%ESS-I-PURGE, Purge operation completed successfully.
```

This command compares versions of X terminal files installed on the DK1 disk with the new versions supplied on the compact disc in the DK2 drive. If older versions of the files are found on DK1, these older versions are purged.

REBOOT

REBOOT

Ends all active service connections and reinitializes the InfoServer system.

Format

REBOOT [YES]

Parameter

YES

Initiates the shutdown procedure.

Description

You use the **REBOOT** command to reboot the InfoServer system. The **REBOOT** command ends all active service connections by remote clients and starts the InfoServer bootstrap sequence.

If you omit the **YES** keyword, the InfoServer system prompts you to confirm the shutdown.

Example

```
InfoServer> REBOOT  
_Are you sure you want to reboot the InfoServer now [No]? YES
```

This command starts the reboot sequence. The user is asked to confirm the command.

RECORD

Records data from an InfoServer disk or partition to a writable compact disc.

Format

```
RECORD src_device[:partition] dest_device[:] [TIME minutes] [SPEED {1 | 2}] [ISO | HSFS]  
[SIZE bytes] [TEST]
```

Parameters

src_device[:partition]

Specifies the source device, which must be a valid InfoServer disk or partition.

dest_device[:]

Specifies the destination device, which must be the recorder compact disc drive.

Options

TIME

Specifies the interval, in minutes, at which the recording software displays updates. For example, a value of 2 specifies that updates be displayed every two minutes. The default value is one minute.

SPEED

Specifies the speed factor at which data is transferred from the source drive to the destination compact disc drive. A value of 1 indicates the speed at which an audio compact disc is read and is the default value for the JVC XR-W1001 recorder. For other recorders, the default value is 2.

ISO or HSFS

Specifies ISO 9660 or High Sierra File System format. If you do not specify this option, the data is recorded in the client's native file format.

SIZE

Specifies the size, in bytes, of the source disk or partition. By default, the recording is the size of the source disk or partition. You can use the SIZE option to override the default value.

TEST

On recorders that support test mode, disables physical recording so that the recording process can be verified before writing data to the compact disc. For example, you might want to check whether the source disk drive can transfer data to the Sony CDW-900E compact disc drive at the specified speed.

RECORD

Description

You use the **RECORD** command to record data either in native format or, using a formatter, in ISO 9660 or High Sierra File System (HFST) format. For detailed instructions on performing recording operations, see Section 4.12.

Example

```
InfoServer> RECORD DK5:ULTRIX_DATA DK2: TIME 2
```

This command records data from the partition **DK5:ULTRIX_DATA** to the recorder drive **DK2**. The command requests that recording progress updates be provided every two minutes.

RESTORE

Restores the system state and all services from the last saved configuration.

Format

RESTORE [*device[:]*]

Parameter

device[:]

Specifies a valid InfoServer device, as defined in Table 2–1, to use for the restore procedure. Tapes are not used for restore operations.

If you omit the device name, the InfoServer system uses, in order, one of the following:

- 1 NVRAM (nonvolatile random-access memory) for InfoServer 1000 systems
- 2 The device from which the system booted, if the device is writable
- 3 The InfoServer-formatted device with the lowest device number

Description

You use the RESTORE command to restore a previously saved system configuration. The SAVE command lets you save any services offered with the CREATE SERVICE command, as well as any InfoServer characteristics changed with the SET command. The settings are saved on an InfoServer read/write device. The RESTORE command resets the running InfoServer system to its last saved settings.

Note

The RESTORE command does not delete any existing services before restoring previously saved services. Therefore, any saved services are added to the existing list of services. Currently active services are not replaced by restored services.

RESTORE

Example

```
InfoServer> RESTORE DK1:  
%ESS-I-RESTORED, Restore completed successfully from DK1:
```

This command restores the last set of InfoServer services and settings saved on the DK1 disk to the running InfoServer system.

RETRIEVE

Restores InfoServer-formatted disks that were saved with the **BACKUP** command.

Format

```
RETRIEVE src_device[:] dest_device[:]
```

Parameters

src_device[:]

Specifies the source device, which must be a valid InfoServer-formatted disk, as defined in Table 2-1.

dest_device[:]

Specifies the destination device, which must be a valid InfoServer-formatted disk, as defined in Table 2-1.

Description

The **RETRIEVE** command requires that the source device was created by the **BACKUP** command. The destination disk is initialized, the partitions are copied, and the services are saved when the partitions are restored.

Note

The **RETRIEVE** command restores services that reference the restored device but does not attempt to save the services to disk. If you want to retain the restored services, you must enter a **SAVE** command. You might want to enter a **SET SERVER STATE ON** command before entering the **SAVE** command.

REWIND

REWIND

Rewinds an InfoServer tape.

Format

```
REWIND device[:]
```

Parameter

device[:]

Specifies a valid InfoServer tape device, as defined in Table 2-1.

Description

The REWIND command rewinds the specified tape but does not unload it.

Example

```
InfoServer> REWIND TP8:
```

This command rewinds the TP8 tape.

SAVE

Saves the current system state to nonvolatile storage.

Format

SAVE [*device[:]*]

Parameter

device[:]

Specifies a valid InfoServer device to use, as defined in Table 2–1. Tapes are not used for SAVE operations.

If you omit the device name, the InfoServer system uses, in order, one of the following:

- 1 NVRAM (nonvolatile random-access memory) for InfoServer 1000 systems
- 2 The device from which the system booted, if the device is writable
- 3 The InfoServer-formatted device with the lowest device number

Description

The SAVE command lets you save the current InfoServer state on a writable InfoServer device. This action allows the InfoServer system to restore service information quickly if an interruption occurs, such as a power failure or reboot. When the system reinitializes, it searches all writable devices for the first saved configuration information.

Note

Saving configuration information does not affect user data on the writable device if the device has been initialized. The InfoServer system automatically preallocates space on initialized devices for SAVE operations by creating a partition named CONFIGURATION. To reset your InfoServer system to the factory defaults, simply delete the partition named CONFIGURATION. If you want to save this file, copy it to a partition with a different name.

SAVE

Example

```
InfoServer> SAVE DK1:  
%ESS-I-SAVED, Save operation completed successfully to DK1:
```

This command saves the InfoServer system state to the DK1 device.

SET DEVICE

Enables or disables automounting of devices that are not in InfoServer format. When you enter a SET DEVICE command, the change takes effect immediately. Enter a SAVE command to preserve these characteristics across InfoServer reboots.

Format

```
SET DEVICE ALL | device-list AUTOMOUNT {DISABLED | ENABLED}
```

Parameters

ALL

Specifies all eligible devices.

device-list

Specifies a device or list of devices. Use commas to separate devices in a list.

Option

AUTOMOUNT

Controls automounting of devices, such as compact discs, that are not in InfoServer format. If you specify a device list, use commas to separate the devices. Note that to enable specific devices for automounting, serverwide automount must already be enabled. (See the description of the SET SERVER AUTOMOUNT command.)

DISABLED

Disables the AUTOMOUNT option.

ENABLED

Enables the AUTOMOUNT option.

Example

```
InfoServer> SET DEVICE DK3,DK4 AUTOMOUNT ENABLED
```

This command enables automounting for the DK3 and DK4 devices.

SET PARTITION

SET PARTITION

Sets or clears the maintenance operation protocol (MOP) attribute on a partition.

Format

```
SET PARTITION device:partition MOP {DISABLED | ENABLED}
```

Parameter

device:partition

Specifies the partition for which the MOP attribute is enabled or disabled.

Options

DISABLED

Clears the MOP attribute from a partition.

ENABLED

Enables the MOP attribute on a partition.

Description

You use the SET PARTITION command to set or clear the MOP attribute on a partition. When the MOP attribute is enabled on a partition, the InfoServer system downline loads an image from this partition if a client requests an image that matches the partition name. For more information, see the CREATE PARTITION command.

Example

```
InfoServer> SET PARTITION DK1:PR0801ENG MOP ENABLED  
%ESS-I-SET, Set operation completed successfully.
```

This command enables the MOP attribute for the partition DK1:PR0801ENG.

SET SERVER AUTOMOUNT

Allows the InfoServer system to provide access to removable media automatically.

Format

```
SET [SERVER] AUTOMOUNT {DISABLED | ENABLED}
```

Options

DISABLED

Disables the InfoServer system from automatically serving any compact discs by volume label when they are inserted and when the system boots.

ENABLED (D)

Enables the InfoServer system to serve compact discs automatically by volume label when they are inserted and when the system boots. This is the default setting.

Description

The **SET SERVER AUTOMOUNT** command lets you determine whether the InfoServer system automatically serves the compact discs to the network by volume label. When enabled, discs are served as they are inserted and when the system boots. The default setting is enabled.

Example

```
InfoServer> SET SERVER AUTOMOUNT DISABLED
%ESS-I-SET, Set operation completed successfully.
```

This command disables the automount feature of the InfoServer system.

SET SERVER CACHE BUCKETSIZE

SET SERVER CACHE BUCKETSIZE

Changes the size of a cache bucket.

Format

```
SET [SERVER] CACHE BUCKETSIZE {8 | 16 | 32}
```

Parameters

8, 16, 32

Specifies the cache bucket size in blocks.

Description

The **SET SERVER CACHE BUCKETSIZE** command lets you change the size of a cache bucket. You must specify one of the parameter values 8, 16, or 32. Cache buckets determine how many blocks ahead of or behind the current block are loaded into cache when a read from a disk occurs. The number of blocks read is a function of both cache bucket size and the service **READAHEAD** and **READBEHIND** flags (see the **SET SERVICE** command).

Because the new value is read at boot time, the value takes effect the next time the server is booted. The default cache bucket size is 8 blocks.

Example

```
InfoServer> SET SERVER CACHE BUCKETSIZE 16
```

This command sets the cache bucket size to 16 blocks.

SET SERVER CACHE SIZE

Changes the size of cache.

Format

SET [SERVER] CACHE SIZE *size*

Parameter

size

Specifies the cache size in megabytes. Valid values are from 1 to 3 megabytes less than the total amount of system memory.

Description

The default value for the cache size is 3 megabytes. If you choose to run with a smaller cache, the memory not used for cache is allocated in the InfoServer pool memory, which can be used to support other InfoServer functions.

This command is not dynamic. After setting the cache size and saving the new value, you must reboot the InfoServer system for the new value to take effect.

Example

```
InfoServer> SET SERVER CACHE SIZE 2
```

This command sets the cache size to 2 megabytes.

SET SERVER CRASHDUMP

Enables or disables crash dumps.

Format

```
SET [SERVER] CRASHDUMP {DISABLED | ENABLED} [ device[:] ]
```

Parameter

device[:]

Optionally specifies a valid InfoServer disk device, as defined in Table 2–1. If you omit the parameter, the InfoServer system uses, in order, one of the following:

- 1 The device from which the system booted, if the device is writable
- 2 The InfoServer-formatted device with the lowest device number

Options

DISABLED (D)

Disables crash dumps.

ENABLED

Enables crash dumps.

Description

By default, the InfoServer system runs with CRASHDUMP disabled. Normally, you do not need to enable this function. If you experience a software problem that causes your system to crash, you can enable the CRASHDUMP function. The InfoServer system then creates an 8000-block partition called CRASH_PARTITION.

If the InfoServer software crashes while CRASHDUMP is enabled, the InfoServer memory is written to the CRASH_PARTITION partition. You can then copy the data from this partition and submit it to Digital for analysis. The partition cannot be deleted with the DELETE PARTITION command but is removed when CRASHDUMP is disabled.

When CRASHDUMP is enabled, the InfoServer command SHOW SERVER displays the most recent crash dump status information. This single line of information can be helpful in identifying problems if you have experienced InfoServer crashes.



Example

InfoServer> **SET CRASHDUMP ENABLED**
%ESS-I-SET, Set operation completed successfully.

This command enables crash dumps.



SET SERVER EXTENSION

SET SERVER EXTENSION

Specifies a serverwide upper limit, in blocks, for the size of virtual disks created remotely by clients.

Format

SET [SERVER] EXTENSION [LIMIT] *value*

Parameter

value

Specifies the number of blocks, from 64 to 10,000,000. The maximum number allowed depends on disk capacity.

Description

This command lets you limit the size of virtual disks created by clients. The default size is 50,000 blocks.

Example

```
InfoServer> SET SERVER EXTENSION 100000  
%ESS-I-SET, Set operation completed successfully.
```

This command sets an extension limit of 100,000 blocks.

SET SERVER GROUP

Allows the InfoServer manager to specify the LAT terminal server group codes under which the management service is offered.

Format

```
SET [SERVER] GROUP [CODES] {ALL | code-list } {ENABLED | DISABLED}
```

Parameters

ALL

Specifies all group codes (0 to 255) for the SET operation.

code-list

Specifies a set of group code numbers for the SET operation. Group codes are numbers in the range from 0 to 255. You can specify multiple group codes. Group codes separated by a comma (,) indicate single group code numbers. Group codes separated by a hyphen (-) indicate a range of group code numbers.

Options

DISABLED

Removes the group codes specified in *code-list* from the current set of group codes on which the InfoServer system offers its LAT terminal server management interface.

ENABLED

Adds the group codes specified in *code-list* to the current set of group codes on which the InfoServer system offers its LAT terminal server management interface.

Description

The SET SERVER GROUP command lets you enable or disable the LAT terminal server group codes used by the InfoServer system to advertise its management console. The codes range from 0 to 255. To connect to the management console, a terminal server must have at least one group code in common with the InfoServer system. Use the SHOW LAT CHARACTERISTICS command to view the currently enabled LAT group codes.

Default : Group 0 is enabled.

SET SERVER GROUP

Example

```
InfoServer> SET SERVER GROUP 1, 3, 10-20 ENABLED  
%ESS-I-SET, Set operation completed successfully.
```

In this example, group codes 1, 3, and 10 to 20 are added to the group code list that the InfoServer system currently offers.

SET SERVER IDENTIFICATION

Assigns an identification string to the InfoServer system to be used by the LAT protocol.

Format

```
SET [SERVER] IDENTIFICATION "string"
```

Parameter

"string"

Specifies a quoted text string of 0 to 64 printable ASCII characters.

Description

The SET SERVER IDENTIFICATION command assigns a text description to the InfoServer system. The LAT protocol uses this description to identify the system.

Example

```
InfoServer> SET SERVER IDENTIFICATION "InfoServer Floor 3 by copier"  
%ESS-I-SET, Set operation completed successfully.
```

This command uses a text string that identifies an InfoServer system by its location. This string is used to advertise the remote management service to terminal servers.

SET SERVER LASTPORT GROUP

SET SERVER LASTPORT GROUP

Sets the LASTport work group of the InfoServer system.

Format

SET [SERVER] LASTPORT [GROUP] *value*

Parameter

value

Specifies a value, from 0 to 1023, that represents the LASTport group of this InfoServer system. The default group is 0.

Description

LASTport work groups provide a method of segmenting local area networks (LANs) so that services offered by an InfoServer system on one LAN segment are not seen by clients on another segment. To access virtual devices on a particular InfoServer system, client systems must belong to the same work group as that InfoServer system.

One possible environment for this command is an extended LAN. Here, an InfoServer manager might want to restrict clients to the services offered by InfoServer systems on the same LAN segment.

Example

```
InfoServer> SET SERVER LASTPORT GROUP 1
%ESS-I-SET, Set operation completed successfully.
```

This command sets the InfoServer LASTport work group to 1. The InfoServer system then communicates only with client systems that are in work group 1.

SET SERVER LAT_RESPONDER

Enables or disables the LAT Responder function.

Format

```
SET [SERVER] LAT_RESPONDER {DISABLED | ENABLED}
```

Options

DISABLED (D)

Disables the LAT Responder function. This is the default setting.

ENABLED

Enables the LAT Responder function.

Description

When the LAT Responder function is enabled, the InfoServer system maintains a database of all LAT terminal server services available on the local area network (LAN) and responds to requests for this information from systems that do not maintain such a database.

Example

```
InfoServer> SET LAT_RESPONDER ENABLED
%ESS-I-SET, Set operation completed successfully.
```

This command enables the LAT Responder function.

SET SERVER MOP

Specifies whether the InfoServer system answers maintenance operation protocol (MOP) downline load requests.

Format

```
SET [SERVER] MOP [V4] {DISABLED | ENABLED}
```

Options

V4

Specifies MOP V4.

DISABLED

Disables the InfoServer system's downline-loading capability.

ENABLED (D)

Enables the InfoServer system to perform MOP downline loading. This is the default setting.

Description

The SET SERVER MOP command provides the InfoServer manager with a convenient way to enable or disable the InfoServer system's MOP downline-loading capability. If the system does not need to perform MOP downline loading, disabling the function can enhance system performance.

The InfoServer supports both Version 3.0 and Version 4.0 MOP protocols. The default configuration enables MOP V3 downline loading and disables MOP V4. When MOP V4 is enabled, the InfoServer responds to both V3 and V4 downline load requests.

In local area networks with multiple servers, MOP V4 downline loading should be enabled only if there is a specific need to do so—for example, to downline load 802.3-only products. In that case, MOP V4 should be enabled on only one server at a time. Otherwise, attempts by multiple servers to respond to a load request within a brief interval might conflict and cause the load to fail.

For more information on the uses of downline loading, see Section 2.11.4.

Example

```
InfoServer> SET MOP DISABLED  
%ESS-I-SET, Set operation completed successfully.
```

This command disables the InfoServer system's MOP downline-loading function.

SET SERVER MULTICAST

SET SERVER MULTICAST

Sets a timer that determines how frequently the InfoServer system advertises the LAT terminal server remote management interface.

Format

SET [SERVER] MULTICAST [TIMER] *value*

Parameter

value

Specifies a timer value, from 10 to 255 seconds.

Description

This command lets you control how frequently the InfoServer system advertises the LAT terminal server remote management console interface.

Default: 60 seconds

Example

```
InfoServer> SET SERVER MULTICAST 120
%ESS-I-SET, Set operation completed successfully.
```

This command sets the InfoServer system to advertise every 120 seconds.

SET SERVER NAME

Changes the name that identifies the InfoServer system on the extended local area network (LAN).

Format

```
SET [SERVER] NAME server-name
```

Parameter

server-name

Specifies the name of the InfoServer system. The system uses a unique default name of the form LAD_ *Ethernet address* (for example, LAD_0800020000FF) until a new name is set with this command. The name can be up to 16 characters in length. Section 2.8.1 lists the characters you can use in InfoServer names.

Description

The SET SERVER NAME command lets you select a name string that identifies the InfoServer system on the extended LAN. This name allows you to identify an InfoServer system by using the SHOW SERVER command. The InfoServer name is also used to provide a LAT terminal server service to which you can connect from a terminal to manage the InfoServer system.

Note

InfoServer names must be unique within the extended LAN.

Example

```
InfoServer> SET SERVER NAME LAB1_INFOSERVER
%ESS-I-SET, Set operation completed successfully.
```

This command sets the InfoServer name to LAB1_INFOSERVER.

SET SERVER PASSWORD

SET SERVER PASSWORD

Allows the InfoServer manager to change the InfoServer password.

Format

```
SET [SERVER] { NOPASSWORD  
              PASSWORD string } [ { NONPRIVILEGED }  
                                 { PRIVILEGED   } ]
```

Description

The InfoServer password controls access to InfoServer management sessions. You can specify a privileged or nonprivileged password or no password. Users who log in using the nonprivileged password can perform only SHOW and HELP operations.

You can set either password to the null string by specifying NOPASSWORD.

The default privileged password is ESS. The default non-privileged password is INFOSERVER. If both the PRIVILEGED and NONPRIVILEGED keywords are omitted, the default is PRIVILEGED. If both the privileged and nonprivileged passwords are identical, the session is logged in as a privileged session.

Example

```
InfoServer> SET SERVER PASSWORD PRIVILEGED  
_New password: SECRET (not echoed)  
_Verification: SECRET (not echoed)  
%ESS-I-SET, Set operation completed successfully.
```

This command sets the InfoServer privileged password to SECRET.

SET SERVER PROMPT

Allows the InfoServer manager to change the InfoServer prompt.

Format

```
SET [SERVER] PROMPT "string"
```

Parameter

"*string*"

A string enclosed in quotation marks (" "). A space is automatically inserted between the last character of the string and the first character a user types. The prompt string can contain a maximum of 24 alphanumeric characters.

Description

The SET SERVER PROMPT command changes the default InfoServer> prompt. To save the prompt across reboots, you must issue the SAVE command.

Example

```
InfoServer> SET SERVER PROMPT "DocServer>"  
DOCServer> SAVE  
%ESS-I-SAVED, Save operation completed successfully to DK1:
```

These commands set the InfoServer prompt to DocServer> and save the prompt.

SET SERVER REMOTE

SET SERVER REMOTE

Specifies a device or list of devices on which remote clients can create virtual disks.

Format

```
SET [SERVER] REMOTE [DEVICE] device-list {DISABLED | ENABLED}
```

Parameter

device-list

Specifies a writable disk or list of writable disks. Use commas to separate devices in a list.

Options

DISABLED

Removes the specified device or devices from the InfoServer system's Remote Device List.

ENABLED

Adds the specified device or devices to the InfoServer system's Remote Device List.

Description

The **SET SERVER REMOTE** command enables remote clients to create virtual disks on InfoServer writable disks. Specifying **ENABLED** with device names adds the devices to the InfoServer system's Remote Device List (displayed with the **SHOW SERVER** command). Specifying **DISABLED** with device names removes the devices from the list. Specifying device names without **ENABLED** or **DISABLED** replaces any devices in an existing Remote Device List with the devices specified with the **SET SERVER REMOTE** command.

Example

```
InfoServer> SET SERVER REMOTE DK1: ENABLED
ESS-I-SET, Remote Device List: DK1
InfoServer> SHOW SERVER

DEC InfoServer 1000 V3.2      (BL22C)      System Image:  Oct 15 1994 07:28:29
Server Name:                  TEST ESS      Uptime:         002 18:51:54
Ethernet Address: 08-00-2b-15-e $\bar{f}$ -50      Server State:   On
Write Access Policy: Pre-emptive      Current Work Group: 0
Service Extension Limit: 50000        Client Limit:    150

Remote Device List:
  DK1

Enabled characteristics:
  MOP downline loading, Automount disks

Last software crash information:
  Exception 11, Curr 5, SP 8005dd7c, PC 800093d7, PSL 4150008.
```

The SET SERVER REMOTE command adds the DK1 device the InfoServer system's Remote Device List.

SET SERVER STATE

SET SERVER STATE

Determines whether new service connections are established.

Format

```
SET [SERVER] STATE {OFF | ON | SHUT}
```

Parameters

OFF

Tells the InfoServer system to end all current connections and not to accept new connections.

ON

Tells the InfoServer system to accept new connection requests.

SHUT

Tells the InfoServer system to keep all current connections but not to accept new connections.

Description

The **SET SERVER STATE** command tells the InfoServer system which actions to take when it receives a new service connection request from a client. The InfoServer state does not affect LAT terminal server connections used to manage the InfoServer system.

Example

```
InfoServer> SET SERVER STATE SHUT  
%ESS-I-SET, Set operation completed successfully.
```

This command shuts off new connections, but keeps all current connections. You might use this command when you plan to turn off the InfoServer system in the near future for maintenance.

SET SERVER WRITE ACCESS

Sets the write policies for InfoServer virtual disk services.

Format

```
SET [SERVER] WRITE [ACCESS] {BLOCKING | PRE-EMPTIVE}
```

Parameters

BLOCKING

Tells the InfoServer system to block writers from accessing a service until all readers have disconnected from the service.

PRE-EMPTIVE (D)

Tells the InfoServer system to allow writers to access a service and end all read sessions to the service. Pre-emptive is the default write access mode.

Description

The **SET SERVER WRITE ACCESS** command allows the InfoServer manager to set the write policies that govern access to all InfoServer read/write services. There are two choices:

- 1 Allow the readers to remain connected and deny access to the writer.
- 2 Disconnect the readers and let the writer connect. Only one writer at a time can access a service, regardless of the write-access policy.

You might use this command when you want to perform nightly updates of a database on a virtual disk. Each night a writer could connect to a service to update the database, disconnecting any read-only connections. After the writer disconnects, the readers could reconnect and access the new data on the virtual disk.

Example

```
InfoServer> SET SERVER WRITE ACCESS PRE-EMPTIVE
%ESS-I-SET, Set operation completed successfully.
```

This command tells the InfoServer system to disconnect any read-only connections when a writer connects to a service.

SET SERVICE

Modifies the attributes of an existing service.

Format

```
SET SERVICE service-name [FOR device[:partition]] [CLASS class-name] [options ]
```

Parameters

service-name

Specifies the name of a service to be modified. The service name can contain wildcard characters.

FOR *device[:partition]*

The specified device can be either of the following:

- **DK*n*:**
Specifies a valid InfoServer disk device, as defined in Table 2–1. If you do not supply a partition name, the service is modified for the entire disk. If you do supply a partition name, the service is modified for the partition on the disk. The partition must already exist on the disk.
- **TP*n*:**
Specifies a valid InfoServer tape device, as defined in Table 2–1.

Because an InfoServer system can have multiple devices with the same service name, this option lets you qualify which service you want to modify. If you omit this parameter, all service names that satisfy the other options are modified.

CLASS *class-name*

Specifies the namespace in which this service name exists. If you include this parameter, the InfoServer system searches only the specified class. If you omit this parameter, all service names that satisfy the other options are modified.

You use different namespaces for different on-disk structures used by various client systems. The purpose is to partition the namespaces so that clients see only names that are meaningful to them. This method also allows two services to have the same name and not conflict.

The class name used depends on the client systems that connect to the service being created. For example, OpenVMS systems use the ODS_2 namespace by default when attempting to mount an InfoServer device. Table 3–2 lists valid *class-name* parameter values.

Default names are ODS_2 (if a DK device is specified) and TAPE (if a TP device is specified).

Options

DYNAMIC_RATING

Specifies that the InfoServer system should calculate a rating for this service dynamically. This is the default method for the service ratings.

[NO]PASSWORD *string*

Specifies an optional access control password for the service. The password string can be up to 39 alphanumeric ASCII characters in length. After you set a password, a client must specify the password to access the service. If you do not specify a password in this command, clients are not required to provide a password to access the service.

You can enter the password without having it echoed on the screen by entering the **PASSWORD** option as the last option in the **CREATE SERVICE** command. After entering the keyword **PASSWORD**, press Return. The InfoServer system prompts you for the password.

[NO]READAHEAD

Determines whether blocks following a request are also inserted into cache. The number of blocks read into cache is determined by the **BUCKETSIZE** parameter of the **SET SERVER CACHE** command. If the **READAHEAD** attribute is enabled, the blocks following a request are loaded into cache from the beginning of the bucket up to the current request.

[NO]READBEHIND

Determines whether blocks preceding a request are also inserted into cache. The number of blocks read into cache is determined by the **BUCKETSIZE** parameter of the **SET SERVER CACHE** command. If the **READBEHIND** attribute is enabled, the blocks preceding a request are loaded into cache from the beginning of the bucket up to the current request.

[NO]READERS *number*

Specifies the maximum number of client connections allowed for read access. The default is 1000 readers. A value of 0 indicates write-only access, as qualified by the **WRITERS** option, if present. If a client requests read-only access or read/write access to the service then one reader is counted against this number.

SET SERVICE

STATIC_RATING *rating*

Specifies a rating from 0 to 65535 to use for load balancing across redundant services. Clients always choose a higher rating over a lower one. If you omit the **STATIC_RATING** option, the InfoServer system calculates a dynamic rating based on InfoServer load.

[NO]WRITERS *number*

Specifies the maximum number of client connections allowed for write access. The default is one writer. A value of 0 indicates read-only access, as qualified by the **READERS** option, if present. If a client requests write-only access or read/write access to the service, one writer is counted against this number.

Note

The InfoServer system does not allow more than one writer to connect to a read/write service at one time. See the **SET SERVER WRITE ACCESS** command for more information regarding the write-access policies described in Section 2.10.

Description

The **SET SERVICE** command lets you modify the attributes of an existing service. The network manager can change the rating, password, number of readers, or number of writers associated with a service.

You can modify all instances of a service name or a particular service name qualified by device and class name. You can use the *device[:partition]* and **CLASS** parameters to specify the exact service name you want to modify. If you want to modify all instances of a service name, omit these parameters. The service name can include wildcard characters.

Example

```
InfoServer> SET SERVICE ONLINE_DOC FOR DK11: NOPASSWORD
%ESS-I-SET, Set operation completed successfully.
```

This command tells the InfoServer system to remove the password currently required to access the **ONLINE_DOC** service, which represents the **DK11** device.

SHOW DEVICE

Displays the characteristics and device-specific information about one or all devices connected to the InfoServer system.

Format

```
SHOW DEVICE [device[:]] {BRIEF | FULL}
```

Parameter

device[:]

Specifies a valid InfoServer device, as defined in Table 2–1. If you omit this parameter, the system displays all the devices on the InfoServer system.

Options

BRIEF

Provides an abbreviated one-line summary of information for each device connected to the system. BRIEF is the default if you omit the device name or specify a single device.

FULL

Provides all device-specific information for the devices connected to the InfoServer system. The FULL option lists all services bound to the device.

Description

The SHOW DEVICE command displays device-specific information for one or all devices connected to the InfoServer system. This information includes the device type, device name, Small Computer Systems Interface (SCSI) bus address, device size, volume label, and automount status. AME in the Device Char field indicates that automount is enabled for the device.

Table 3–3 describes the fields displayed by SHOW DEVICE commands.

SHOW DEVICE

Table 3-3 SHOW DEVICE Display Fields

Field	Description
Device Name	The name that the InfoServer system has assigned to the device.
Device State State	The current state of the device. For this release, devices are always on.
Device	The type of device attached to the unit. The device can be one of the following: Hard disk (read/write disk) Compact disc Tape
Device Type	An ASCII string (such as RRD42) that the device returns to identify itself.
Device Address	The bus and unit number of the attached SCSI device.
Device Size/ Record Num. Device Size	If the device is a disk, the number of blocks available on the attached disk. If the device is a tape, the current record number at which the tape is positioned. Tape position 0 is the beginning of the tape.
Volume Label Volume Name	The label or name of the volume currently in the device.
Device Char Device Characteristics	The automount status of the volume. The designation AME indicates that automount is enabled for the volume.
SCSI Bus/Id	The bus identification number for the device.
Current Sessions	The total number of sessions connected to this device or to any partitions on the device.
Services bound to Port	A list of services that are currently available to the network for the specified device.

Examples

1. InfoServer> SHOW DEVICE

Device Name	Device State	Device Type	Device Address	Dev. Size/ Record Num.	Volume Label	Device Char
DK1:	On	Hard Disk	A/001	204864	BOOT_PAR	
DK2:	On	Compact Disc	A/002	1216980	CD_DOC_01221	AME
TP13:	On	Tape	B/005	0		

This command displays a one-line summary of all devices connected to the InfoServer system.

2. InfoServer> SHOW DEVICE DK2: FULL

Device Name:	DK2:	Current Sessions:	3
State:	On	Device Size:	1216980
Device:	Compact Disc	Volume Name:	CD_DOC_01221
Device Type:	RRD42	SCSI Bus/Id:	A/002

Device Characteristics:
Automount Enabled

Services bound to Port:
CD_DOC_01221 [ODS_2] DK2: [3 connections]

This command displays detailed information for device DK2, including the services offered for the device.

SHOW ETHERNET

SHOW ETHERNET

Displays data link and LASTport protocol counters.

Format

SHOW ETHERNET [COUNTERS]

Description

The **SHOW ETHERNET** command displays errors and counters kept by the InfoServer system for the Ethernet data link and for the LASTport protocol.

Example

```
InfoServer> SHOW ETHERNET
DEC InfoServer 1000 V3.2 (BL22C) LAD V3.1 LAST V3.1 Uptime 000 00:01:35
Seconds Since Zeroed:      95      Frame Sent, 1 Collision:      1
Bytes Received:            37110    Frames Sent, 2+ Collisions:   0
Bytes Sent:                256      Send Failures:               0
Frames Received:          12949     Send Failure Reasons:       0000000000
Frames Sent:               4        Receive Failures:           0
Multicast Bytes Rcv'd:    37160     Receive Failure Reasons:    0000000000
Multicast Bytes Sent:     256      Unrecognized Destination:    12350
Multicast Frames Rcv'd:  12993     Data Overrun:               0
Multicast Frames Sent:    4        User Buffer Unavailable:     0
Frames Sent, Deferred:    2        System Buffer Unavailable:   1

LAST Counters -
Messages Received:        246      Transaction Segments Missed: 0
Messages Transmitted:    0        Canceled Transactions:      0
Checksum OK:             0        Checksum Errors:            0
Multicast Msgs Rcv'd:    0        Congestion:                 0
```

This example shows the display generated by the **SHOW ETHERNET** command. Table 3-4 describes the fields displayed in **SHOW ETHERNET** commands.

Table 3-4 SHOW ETHERNET Display Fields

Field	Description
DEC InfoServer 1000 V3.2 (BL22C)	The product designation and software version number.
LAD V3.1 LAST V3.1	The version number of the LASTport/Disk and LASTport protocols being used by the InfoServer system.
Uptime	The time the InfoServer system has been running since the last reboot. The time is shown in the following format: <i>days hours:minutes:seconds</i>
Seconds Since Zeroed	The number of seconds since these counters were last set to 0.
Bytes Received	The number of bytes contained in datagrams successfully received by the InfoServer system, excluding Ethernet header and cyclic redundancy check (CRC) data.
Bytes Sent	The number of bytes contained in datagrams successfully transmitted by the InfoServer system, excluding Ethernet header and CRC data.
Frames Received	The number of datagrams successfully received by the InfoServer system, including multicast frames.
Frames Sent	The number of datagrams successfully transmitted by the InfoServer system, including multicast frames.
Multicast Bytes Rcv'd	The number of bytes received by the InfoServer system in multicast frames, excluding Ethernet header and CRC data.
Multicast Bytes Sent	The number of bytes transmitted by the InfoServer system in multicast frames, excluding Ethernet header and CRC data.

(continued on next page)

Table 3-4 (Cont.) SHOW ETHERNET Display Fields

Field	Description
Multicast Frames Rcv'd	The number of multicast frames received by the InfoServer system.
Multicast Frames Sent	The number of multicast frames transmitted by the InfoServer system.
Frames Sent, Deferred	The number of times that the InfoServer system deferred a frame transmission because the data link was in use.
Frames Sent, 1 Collision	The number of times the InfoServer system transmitted a frame on the second attempt after a collision occurred on the first attempt.
Frames Sent, 2+ Collisions	The number of times the InfoServer system successfully sent a frame after collisions during the first two or more attempts.
Send Failures	The number of times the Ethernet interface aborted a transmission request. If this count is not 0, see the Send Failure Reasons field for more information.
Send Failure Reasons	<p>A bit mask providing information about the send failure if the Send Failures counter is not 0. The bits in the mask are numbered from right to left, with bit 0 being the rightmost bit. The following bits are defined in the mask:</p> <ul style="list-style-type: none"> 0 A transmission failed to complete after 16 retries, usually due to excessive collisions. 1 A loss of carrier occurred on the Ethernet during a transmission. 2 A short circuit occurred on the Ethernet during a transmission. 3 An open circuit occurred on the Ethernet during a transmission. 4 Heartbeat error. 5 Data underflow.

(continued on next page)

Table 3-4 (Cont.) SHOW ETHERNET Display Fields

Field	Description
Receive Failures	The number of frames that were received with an error condition. For more information, see the Receive Failure Reasons field.
Receive Failure Reasons	A bit mask providing information about the type of receive failures encountered if the Receive Failures counter is not 0. The bits in the mask are numbered from right to left, with bit 0 being the rightmost bit. The following bits are defined in the mask: <ul style="list-style-type: none"> 0 A block check error. The received frame did not pass the CRC check. 1 A framing error. The received packet did not contain an integral number of 8-bit bytes.
Unrecognized Destination	The number of frames received by the InfoServer system that did not contain a multicast address or protocol type recognized by the system. These frames are discarded.
Data Overrun	The number of times that the InfoServer hardware lost an incoming frame because it was unable to keep up with the data rate.
User Buffer Unavailable	Currently unused. Should always be 0.
System Buffer Unavailable	The number of times that the InfoServer system software did not have a buffer available to receive an incoming frame (MISS error).
Messages Received	The number of LASTport protocol messages successfully received by the InfoServer system.
Messages Transmitted	The number of LASTport protocol messages successfully transmitted by the InfoServer system.

(continued on next page)

SHOW ETHERNET

Table 3-4 (Cont.) SHOW ETHERNET Display Fields

Field	Description
Checksum OK	The number of times that a LASTport message was received that correctly passed the LASTport checksum algorithm. A checksum of LASTport messages occurs only at the request of the client systems.
Multicast Messages Rcv'd	The number of LASTport messages successfully received with the LASTport multicast address.
Transaction Segments Missed	The number of times that the InfoServer system did not receive all the messages of a client request, when the client requested more than one message.
Canceled Transactions	The number of times that remote clients canceled a LASTport request that the InfoServer system was processing.
Checksum Errors	The number of times that a LASTport message was received that did not pass the LASTport checksum algorithm. A checksum of LASTport messages occurs only at the request of the client systems.
Congestion	The number of times that the client system and InfoServer system agreed to reduce the message rate because of too many messages being delivered to either the InfoServer system or the client.

SHOW FUNCTIONS

Displays both currently installed functions and functions that are available but not installed.

Format

SHOW FUNCTIONS

Description

The SHOW FUNCTIONS command lists all available InfoServer functions. Functions in the Other Functions Available column are not currently installed. If you purchase such functions, use the UPDATE FUNCTIONS command to install them.

Example

```
InfoServer> SHOW FUNCTIONS
```

```
          * Function Information for InfoServer V3.2 *
```

```
InfoServer Functions Installed:      Other Functions Available:
-----
X terminal services                  Open tape access (any client)
Open disk access (any client)
```

Additional functions from the 'Other Functions Available' list can be installed from Function-CDROMs available from Digital. Contact your Digital representative to purchase additional functions.

The SHOW FUNCTIONS command shows that X terminal services and Open disk access functions are installed on this InfoServer system. An Open tape access function is available but is not installed.

SHOW LAST

SHOW LAST

Displays information about LASTport transport sessions.

Format

```
SHOW [LAST] SESSIONS [CLASS class-name]
```

Option

CLASS *class-name*

Displays sessions connected to services in the specified service class. If you specify CLASS, you must specify a valid class name listed in Table 3-2.

Description

The SHOW LAST command lists session and client information for InfoServer services.

Example

```
InfoServer> SHOW LAST
Service: DECLEARN (for DK13:, class ODS_2)
  Session: 15004 Client: HOBBLE
  Session: 02004 Client: CYBORG
  Session: 11604 Client: QUININE
  Session: 01404 Client: BROWNY
```

The SHOW LAST command displays information about LASTport sessions for all InfoServer services with current connections. In this example, DECLEARN is the only service with current connections.

SHOW LAT

Displays InfoServer LAT terminal server counters and characteristics and information about current LAT terminal server sessions.

Format

SHOW LAT {COUNTERS | SESSIONS}

Options

COUNTERS

Specifies that LAT terminal server counters and characteristics be displayed.

SESSIONS

Specifies that information about LAT terminal server sessions be displayed.

Description

The SHOW LAT command displays LAT terminal server characteristics set up for the InfoServer system, as well as errors and counters kept by the system for the LAT protocol. The command also displays information on current InfoServer LAT terminal server sessions.

Examples

1. InfoServer> **SHOW LAT COUNTERS**

```

* LAT Counters *
Seconds Since Zeroed: 106   Duplicates Received: 0
Messages Received: 0      Messages Retransmitted 0
Messages Transmitted: 3   Illegal Messages Received: 0
Slots Received: 0        Illegal Slots Received: 0
Slots Transmitted: 0     Virtual Circuit Timeouts: 0
Bytes Received: 0        Protocol Errors: 0
Bytes Transmitted: 0     Protocol Error Mask: 0000000000000
Services Cached: 58
Nodes Cached: 11

```

SHOW LAT

* LAT Characteristics *

Name: TEST_INFOSERVER
Identification: "Test InfoServer 1000, near floor 3 copy machine"
Multicast timer: 60
LAT Responder: Enabled
Enabled Group Codes: 0, 12, 250-255

This example displays LAT terminal server counters. Table 3–5 describes the fields.

2. InfoServer> SHOW LAT SESSIONS

* LAT Sessions *

Process Number: -----	Connection State: -----	Connected Node/Port: -----
1	Idle	
2	Idle	
3	Connected	NODE21::PORT_610025

This example displays information about current LAT terminal server sessions. Table 3–6 describes the fields.

Table 3–5 SHOW LAT COUNTERS Display Fields

Field	Description
Seconds Since Zeroed	The number of seconds since these counters were last set to 0.
Messages Received	The number of LAT protocol messages successfully received by the InfoServer system.
Messages Transmitted	The number of LAT protocol messages successfully transmitted by the InfoServer system.
Slots Received	The number of LAT slots received by the InfoServer system. A slot represents a message segment for a particular LAT terminal server session.
Slots Transmitted	The number of LAT slots transmitted by the InfoServer system. A slot represents a message segment for a particular LAT terminal server session.

(continued on next page)

Table 3-5 (Cont.) SHOW LAT COUNTERS Display Fields

Field	Description
Bytes Received	The number of data bytes received by the InfoServer system over the LAT protocol.
Bytes Transmitted	The number of data bytes transmitted by the InfoServer system over the LAT protocol.
Services Cached	The number of LAT terminal server services for which the server has stored information.
Nodes Cached	The number of nodes for which the server has stored information.
Duplicates Received	The number of virtual circuit messages the InfoServer system received that were not in the correct sequence.
Messages Retransmitted	The number of virtual circuit messages that the InfoServer system retransmitted to remote nodes.
Illegal Messages Received	The number of incorrectly formatted LAT messages that the InfoServer system has received.
Illegal Slots Received	The number of incorrectly formatted slots of data in a LAT terminal server message that the InfoServer system has received.
Virtual Circuit Timeouts	The number of times that the InfoServer system terminated a LAT terminal server connection because the remote node did not respond within the time allowed by the LAT protocol.
Protocol Errors	The number of times that the InfoServer system determined that the LAT protocol had been violated by a remote node. See the Protocol Error Mask field for more information.

(continued on next page)

Table 3-5 (Cont.) SHOW LAT COUNTERS Display Fields

Field	Description
Protocol Error Mask	<p>A bit mask providing information about the LAT protocol errors detected by the InfoServer system. The bits in the mask are numbered from right to left, with bit 0 being the rightmost bit. The following bits are defined in the mask:</p>
0	An unknown LAT message type was received.
1	An invalid LAT START message was received.
2	A zero-valued virtual circuit reference was received.
3	An out-of-range virtual circuit reference was received.
4	A reference to a nonexistent virtual circuit was received.
5	A reference to a virtual circuit no longer in use was received.
6	An invalid LAT STOP message was received.
7	An invalid reference to a remote slot was received.
8	A reference to a nonexistent slot was received.
9	A credit violation was detected.
10	A repeated creation of a slot was detected.
11	An invalid sequence number was received.
12	A repeated disconnect of a slot was detected.

(continued on next page)

Table 3–5 (Cont.) SHOW LAT COUNTERS Display Fields

Field	Description
Name	The name of the InfoServer system. This name is also the service name to which terminal servers connect to manage the InfoServer system.
Identification	The identifying text string that the InfoServer uses to advertise to the terminal server network.
Multicast Timer	The number of seconds that the InfoServer system uses to advertise its remote management interface periodically.
LAT Responder	The field that shows whether the LAT Responder function is enabled or disabled.
Enabled Group Codes	The group code numbers that the InfoServer system is using to advertise its remote management interface.

Table 3–6 SHOW LAT SESSIONS Display Fields

Field	Description
Process Number	The number of the connected process.
Connection State	The field that shows Whether the connection is active or idle.
Connected Node/Port	The name of the connected node and port.

SHOW MOP

Displays the server's maintenance operation protocol (MOP) counters.

Format

SHOW MOP [COUNTERS]

Description

The SHOW MOP command displays information on errors and counters that the InfoServer system keeps for the MOP protocol.

Example

```
InfoServer> SHOW MOP

                               * MOP Counters *
Seconds Since Zeroed:          4697   Load failed, server limit:          0
Messages Received:             0      Load failed, not contiguous:         0
Messages Transmitted:          0      Load failed, file not found:         0
Messages Re-transmitted:       0      Load failed, read error:             0

Request IDs Received:          0      Load failed, timeout:                0
Read Counters Received:        0      Load failed, protocol error:         0
LOOP Messages Received:        0      Load failed, no memory:              0

Loads in progress:             0      Load failed, file too big:           0
Successful loads:              0      Load failed, bad file type:          0
Total loads processed:         0      Load failed, partition type:         0

Failure cache attempts:        23336   Success cache attempts:              13
Failure cache hits:            23323   Success cache hits:                   4
Failure cache hit ratio:       99%     Success cache hit ratio:              30%
Cache flushes:                 0
```

*** MOP downline loading has been disabled.

This example shows the display generated by the SHOW MOP command. Table 3-7 describes the fields.

Table 3-7 SHOW MOP Display Fields

Field	Description
Seconds Since Zeroed	The number of seconds since these counters were last set to 0.
Messages Received	The number of MOP messages successfully received by the InfoServer system.
Messages Transmitted	The number of MOP messages successfully transmitted by the InfoServer system.
Messages Re-transmitted	The number of MOP downline load messages that the InfoServer system retransmitted to the requesting node.
Request IDs Received	The number of MOP request identity messages that the InfoServer system has received to which it has responded.
Read Counters Received	The number of MOP request messages that the InfoServer system has received and to which it has responded.
LOOP Messages Received	The number of MOP LOOP messages that the InfoServer system has received and to which it has responded.
Loads in progress	The current count of systems that the InfoServer system is downline loading.
Successful loads	The number of times that the InfoServer system successfully downline loaded a remote system.
Total loads processed	The total number of downline load requests to which the InfoServer system responded, including successful and unsuccessful load attempts.
Load failed, server limit	The number of times that the InfoServer system was unable to process a downline load request because it was currently handling the maximum number of concurrent downline loads.

(continued on next page)

Table 3-7 (Cont.) SHOW MOP Display Fields

Field	Description
Load failed, not contiguous	The number of times that the InfoServer system was unable to process a downline load request because an internal format error was detected in the downline load image.
Load failed, file not found	The number of times that the InfoServer system received a downline load request, but did not have the requested downline load image.
Load failed, read error	The number of times that the InfoServer system was unable to process a downline load because an error occurred while trying to read the disk.
Load failed, timeout	The number of times that the InfoServer system began to process a downline load request, but terminated the downline load because the remote system did not complete the request within the time limit.
Load failed, protocol error	The number of times that the InfoServer system was unable to complete a downline load request because it detected a downline load protocol error in the remote system's request.
Load failed, no memory	The number of times that the InfoServer system was not able to complete a downline load request because it did not have sufficient memory pool.
Load failed, file too big	The number of times that the InfoServer system attempted to process a secondary load request, but was unable to fit the entire image into a single MOP downline load message.
Load failed, bad file type	The number of times that the InfoServer system was unable to complete a downline load request because it was unable to read the downline load file type in a partition.

(continued on next page)

Table 3-7 (Cont.) SHOW MOP Display Fields

Field	Description
Load failed, partition type	The number of times that the InfoServer system located a partition with the name requested by the remote system, but was unable to downline load the image because the partition was not specified as a MOP partition.
*** MOP downline loading has been disabled.	This field is present only if the InfoServer MOP characteristic has been disabled, indicating that the InfoServer system does not process MOP downline load requests received.

SHOW PARTITIONS

SHOW PARTITIONS

Lists all the partitions on an InfoServer device.

Format

```
SHOW PARTITIONS device[:partition] {BRIEF | FULL}
```

Parameter

device[:partition]

Specifies a valid InfoServer disk device, as defined in Table 2–1. Tape devices are not partitioned.

The partition must already exist on the specified device. The partition name can contain wildcard characters.

Options

BRIEF

Provides a display of the specified device's named partitions that match the specified input partition name.

FULL

Provides a display of all the specified device's partitions that match the specified input partition name, including any deleted partitions. The display also provides information on disk usage.

Description

You use the SHOW PARTITIONS command to list the partitions on an InfoServer device. The command lists partition names and sizes. The command can also list any deleted partitions available for reuse, as well as the remaining space on the disk. The SHOW PARTITIONS command supports full wildcard expressions.

Examples

1. InfoServer> **SHOW PARTITIONS DK1:C***

Directory DK1:

Partition Name	Used/Alloc	Services
CRASH_PARTITION	8000/8000	
	352/352	FREE
CONFIGURATION	25/64	
CRASH_1	8000/8000	CRASH_1 [ODS_2]

DK1: has 23 partitions in use. 94400 of 204864 blocks allocated.
Largest contiguous free extent is 89264 blocks.

This command lists the named partitions on disk DK1 that match the string C*.

2. InfoServer> **SHOW PARTITIONS DK1: FULL**

Directory DK1:

Partition Name	Used/Alloc	Services
BOOT_PARTITION	5000/5008	TEST_BOOT [ODS_2]
2NDARY CONFIGURATION	17/64	
ISL SVAX_055	127/128	MOP
ISL LVAX_055	127/128	Temp MOP
VXTLDR0200	332/336	VXTLDR [MOP]
VXTAV00200	11019/11024	VXTAV00200.SYS [VXT_SYSTEM], VXTAV0.SYS [VXT_SYSTEM]
IS FUNCTIONS	1/64	NEWFUNCTIONS [ODS_2]
LAB_TEST_1	387/400	LAB_TEST_DATA [ODS_2]
VXT_G.XRM	1/64	VXT_G.XRM [VXT_WORKGRP]
VXT_VI_2.FNT	9984/9984	VXT_VI_2.FNT [VXT_SYSTEM]
	19872/19872	DELETED

DK1: has 23 partitions in use. 94400 of 204864 blocks allocated.
Largest contiguous free extent is 89264 blocks.

This command lists all the partitions on disk DK1, including any previously created partitions that have been deleted. The command also lists a summary of disk usage. Any services bound to a partition appear to the right of the partition size.

Partition DK1:LAB_TEST_1 is currently being served with service name LAB_TEST_DATA in the ODS_2 service class. OpenVMS clients that bind to LAB_TEST_DATA access the partition DK1:LAB_TEST_1.

SHOW PARTITIONS

Table 3-8 describes the fields displayed in SHOW PARTITION commands.

Table 3-8 SHOW PARTITIONS Display Fields

Field	Description
Partition Name	The name of the partition on the specified device.
Used/Alloc	The first size listed for the partition is the block size requested by the CREATE PARTITION command. This is the size used when the partition is served to the network. The second size listed is the actual number of blocks that the InfoServer system used (or reused) for the partition.
Services	Partitions listed with service names are being offered as services to client systems. The service name is listed with the service class in brackets.
MOP	Partitions listed with the MOP flag are MOP partitions capable of being downline loaded.
DELETED	Partitions listed with the DELETED flag are partitions that have been deleted and are available for reuse when new partitions are created.
FREE	The FREE entry shows the number of unused disk blocks for the device. These blocks are free to be used in new partitions.
Temp MOP	The Temp MOP entry shows that the partition is a temporary maintenance operation protocol (MOP) partition.
<i>Summary</i>	The last line indicates a summary of disk usage. This line lists the total number of named partitions on the disk, as well as the total number of blocks on the disk.

SHOW SERVER

Displays InfoServer system characteristics, resources, and counters.

Format

```
SHOW SERVER {CHARACTERISTICS | COUNTERS | STATISTICS}
```

Options

CHARACTERISTICS

Displays server characteristics information.

COUNTERS

Displays server counters.

STATISTICS

Displays server statistics.

Description

The **SHOW SERVER** command displays information about the InfoServer system, including information about internal memory resource utilization, uptime, and idle time.

Table 3–9 describes fields common to all displays. Table 3–10 describes the **SHOW SERVER CHARACTERISTICS** display fields. Table 3–11 describes the **SHOW SERVER COUNTERS** display fields. Table 3–12 describes the **SHOW SERVER STATISTICS** display fields.

SHOW SERVER

Examples

1. InfoServer> SHOW SERVER CHARACTERISTICS

```
DEC InfoServer 1000 V3.2    (BL22C)    System Image:  Oct 15 1994 07:28:29
Server Name:                TEST ESS    Uptime:        002 18:51:54
Ethernet Address: 08-00-2b-15-e7-50    Server State:   On
Write Access Policy: Pre-emptive      Current Work Group: 0
Service Extension Limit:   50000      Client Limit:   100

Remote Device List:

Enabled characteristics:
  MOP downline loading,  Automount disks

Last software crash information:
  Exception 11, Curr 5, SP 8005dd7c, PC 800093d7, PSL 4150008.
```

This command displays server characteristics (see Table 3-10).

2. InfoServer> SHOW SERVER COUNTERS

```
DEC InfoServer 1000 V3.2    (BL22C)    System Image:  Oct 15 1994 07:28:29
Server Name:                TEST ESS    Uptime:        002 18:51:54
Cache Blocks Read:         110669      Tape Records Read: 0
Disk Blocks Read:          218853      Tape Segments Read: 0
Total Blocks Read:         329522      Tape Records Written: 0
Total Blocks Written:      10458      Tape Segments Written: 0
Current Disk Sessions:     132        Current Tape Sessions: 0
Highest Disk Sessions:     236        Highest Tape Sessions: 0
Client Systems:            16
Current Systems:           16
Highest Systems:           40
```

This command displays server counters (see Table 3-11).

3. InfoServer> SHOW SERVER STATISTICS

```
DEC InfoServer 1000 V3.2    (BL22C)    System Image:  Oct 15 1994 07:28:29
Server Name:                TEST ESS    Uptime:        002 18:51:54
Pool Size:                  505560      Cache Size:     3164456
Pool Available:             165876      Cache Hit Ratio: 33%
% of Pool Free:             32%        Cache Bucket Size 16
Current Idle CPU:           98%
Low CPU:                    1%
```

This command displays the server's performance-related statistics (see Table 3-12).

Table 3-9 Fields Common to All SHOW SERVER Displays

Field	Description
DEC InfoServer 1000 V3.2 (BL22C)	The product designation and software version number.
Server Name	The name assigned to the InfoServer system.
System Image	The date the InfoServer software was created.
Uptime	The time the InfoServer system has been running since the last reboot. The time is in the following format: <i>days hours:minutes:seconds</i>

Table 3-10 SHOW SERVER CHARACTERISTICS Display Fields

Field	Description
Ethernet Address	The Ethernet address of the InfoServer hardware unit.
Write Access Policy	The current write-access policy in effect for the server, either pre-emptive or blocking.
Service Extension Limit	The serverwide upper limit, in blocks, for the size of virtual disks created remotely by clients. (See the SET SERVER EXTENSION command.)
Remote Device List	The list of virtual devices created on InfoServer writable disks by remote clients. (See the SET SERVER REMOTE command.)
Enabled characteristics	A list of all of the InfoServer characteristics that are currently enabled. Characteristics are separated by a comma.
Server State	The server state currently set for the InfoServer system: ON, OFF, or SHUT.
Current Work Group	The LASTport group to which the InfoServer system belongs. The system communicates only with clients in the same work group.

(continued on next page)

SHOW SERVER

Table 3-10 (Cont.) SHOW SERVER CHARACTERISTICS Display Fields

Field	Description
Client Limit	The maximum number of clients that are allowed to connect to the server.
Last software crash information	The data from the most recent software crash.

Table 3-11 SHOW SERVER COUNTERS Display Fields

Field	Description
Cache Blocks Read	The number of virtual disk blocks read by a remote client that were fetched from the disk cache (rather than from the disk).
Disk Blocks Read	The number of virtual disk blocks read by a remote client that were fetched from the physical disk (and not from cache).
Total Blocks Read	The total number of virtual disk blocks read by remote clients, from both disk and cache.
Total Blocks Written	The total number of virtual disk blocks that remote client systems wrote to an InfoServer disk.
Current Disk Sessions	The number of disk services currently being accessed by all clients.
Highest Disk Sessions	The highest number of disk services accessed concurrently by all clients. This value is saved when the server reboots.
Current Systems	The number of remote client systems currently accessing services on the InfoServer system.
Highest Systems	The highest number of clients that concurrently accessed services on the InfoServer system. This value is saved when the server reboots.
Tape Records Read	The number of tape records read by a remote client that were fetched from the tape.

(continued on next page)

Table 3–11 (Cont.) SHOW SERVER COUNTERS Display Fields

Field	Description
Tape Segments Read	The total number of segments read by remote clients.
Tape Records Written	The total number of tape records that remote client systems wrote to an InfoServer tape.
Tape Segments Written	The total number of tape segments that remote client systems wrote to an InfoServer tape.
Current Tape Sessions	The number of tape services currently being accessed by all clients.
Highest Tape Sessions	The highest number of tape services accessed concurrently by all clients. This value is saved when the server reboots.

Table 3–12 SHOW SERVER STATISTICS Display Fields

Field	Description
Pool Size	The total number of bytes of memory in the InfoServer pool.
Pool Available	The total number of unused bytes of memory in the InfoServer pool.
% of Pool Free	The percentage of pool memory that is currently available.
Cache Size	The total number of bytes of memory being used as a disk cache for all InfoServer disks. As disk blocks are read, they are saved in memory for quicker access if those same blocks are read again.
Cache Hit Ratio	The percentage of times that the InfoServer system was able to satisfy a client read request by getting the requested blocks from cache.
Cache Bucket Size	The size of a cache bucket. Can be 8, 16, or 32 blocks.

(continued on next page)

SHOW SERVER

Table 3-12 (Cont.) SHOW SERVER STATISTICS Display Fields

Field	Description
Current Idle CPU	The percentage of the available CPU processing time that is currently free.
Low CPU	The lowest value for idle CPU time that the InfoServer system has experienced since the last time the counters were set to 0.



SHOW SERVICE

Displays information about services.

Format

```
SHOW SERVICE [service-name {BRIEF | FULL} [CLASS class-name ]
```

Parameters



service-name

Specifies the name of the service to display. Usually, a service name is the same as the volume label of the disk volume. The service name can contain wildcard characters. If you omit this parameter, the system displays information on all services.

CLASS *class-name*

Selects the service class to display. Requires that you specify a particular *class-name* or a wildcard (*) character for *class-name*.

Options



BRIEF

Provides an abbreviated, one-line summary of information for the specified services. BRIEF is the default if you do not specify a service name on the command line.

FULL

Provides detailed information about the specified services. FULL is the default if you specify a service name in the command line.

Description



The SHOW SERVICE command displays service-specific information for one or all services offered by the server. This information includes the device number associated with each service and the number of connected sessions. The SHOW SERVICE command supports full wildcard expressions.



SHOW SERVICE

Examples

1. InfoServer> **SHOW SERVICE * CLASS ODS_2**

Service Name	Service Class	Disk:Partition	
CONDIST1	[ODS_2]	DK9:	[12 connections]
CD_DOC_01221	[ODS_2]	DK12:	[5 connections]
DECLEARN	[ODS_2]	DK13:	[4 connections]
FT_BOOT_PAR	[ODS_2]		

This command displays summary information for all services in the ODS_2 service class.

2. InfoServer> **SHOW SERVICE CD_DOC_01221 FULL**

CD_DOC_01221	[ODS_2]		
Device Id:	DK2		
Service Rating:	64751	Disk Size:	1217280
Rating:	Dynamic	Password:	Disabled
Max Read Sess:	1000	Max Write Sess:	0
Cur Read Sess:	12	Cur Write Sess:	0
Highest Read Sess:	68	Max Reject Sess:	0
Reads:	7568	Writes:	0
Block Reads:	7568	Block Writes:	0
Service Attributes:	ReadAhead		

This command displays full information for the service CD_DOC_01221, which is offered for device DK2.

3. InfoServer> **SHOW SERVICE BACKUP**

BACKUP	[TAPE]		
Device ID:	TP15:	Password:	Disabled
Service Rating:	42633	Rating Mode:	Dynamic
Max Read Sessions:	1	Current Read Sessions:	0
Max Write Sessions:	1	Current Write Sessions:	0
Records Read:	0	Records Written:	0
Bytes Read:	0	Bytes Written:	0
Segments Read:	0	Segments Written:	0

This command displays full information for the service BACKUP, which is offered for the TP15 device.

4. InfoServer> **SHOW SERVICE MY_PARTITION**

```

MY_PARTITION      [ODS_2]
  Device Id:      DK3      Partition:      MY_PARTITION
  Service Rating: 32636    Disk Size:      1216980
  Rating:         DYNAMIC  Password:       DISABLED
  Max Read Sess: 1000     MAX Write Sess: 0
  Cur Read Sess: 1        Cur Write Sess: 0
  Highest Read Sess: 1    Max Reject Sess: 0
  Reads:         0        Writes:         0
  Block Reads:   0        Block Writes:   0
  Service attributes: Auto-Mounted, ReadAhead

```

This command displays full information for the service **MY_PARTITION**, which is offered for the partition named **MY_PARTITION** on device **DK3**.

Table 3–13 describes the fields displayed in **SHOW SERVICE** commands.

Table 3–13 SHOW SERVICE Display Fields

Field	Description
Service Name	The name assigned to each service listed in the display.
Service Class	The name of the service class under which the specified service is offered; listed in brackets ([]) after the service name.
Disk:Partition Device ID	The names of the disk and partition. The name of the InfoServer device for which that the service is being offered.
Service Rating	The service rating value (from 0 to 65535) currently assigned to the service.
Rating	The type of service rating assigned to the particular service. The rating type can be either STATIC or DYNAMIC .
Max Read Sessions Max Read Sess	The maximum number of concurrent read sessions allowed for the specified service.
Current Read Sessions Curr Read Sess	The current number of read sessions connected to the specified service.
Highest Read Sess:	The highest number of read requests since service creation.

(continued on next page)

SHOW SERVICE

Table 3-13 (Cont.) SHOW SERVICE Display Fields

Field	Description
Reads	The total number of read requests (of any size) issued by remote client systems for the specified service.
Block Reads	The total number of disk blocks that remote client systems have read for the specified service.
Records Read	The total number of tape records that remote client systems have read for the specified service.
Bytes Read	The total number of tape bytes that remote client systems have read for the specified service.
Segments Read	The total number of tape segments that remote client systems have read for the specified service.
Partition	The partition name for which the specified service is offered. This field is not present if the service name is for an entire disk.
Disk Size	The total number of blocks on the disk for which the service is being offered.
Password	The current setting for password protection, ENABLED or DISABLED . The actual service password is not displayed.
Rating Mode	The service rating is either static or dynamic.
Max Write Sessions	The maximum number of concurrent write sessions allowed for the specified service.
Max Write Sess	
Current Write Sessions	The current number of read sessions connected to the specified service.
Current Write Sess	
Max Rejected Sess:	The total number of connect requests rejected since service creation.
Writes	The total number of write requests (of any size) issued by remote client systems for the specified service.

(continued on next page)

Table 3-13 (Cont.) SHOW SERVICE Display Fields

Field	Description
Block Writes	The total number of disk blocks that remote client systems have read for the specified service.
Service Attributes	The attributes enabled for the service.
Records Written	The total number of tape records that remote client systems have written for the specified service.
Bytes Written	The total number of tape bytes that remote client systems have written for the specified service.
Segments Written	The total number of tape segments that remote client systems have written for the specified service.

SHOW TAPE

SHOW TAPE

Displays InfoServer tape protocol counters.

Format

SHOW TAPE [COUNTERS]

Description

The SHOW TAPE command displays the information listed in Table 3–14.

Example

InfoServer> **SHOW TAPE**

```
          * InfoServer LAP (Tape) Protocol Summary *
Seconds Since Zeroed:          16928
Solicit Messages Rcv'd:        0   Connect Failed, Bad Password:      0
Solicit Responses Sent:        0   Invalid Access Requested:      0
Connect Requests Rcv'd:        0   Connection Count Exceeded:     0
Records Read:                  0   Segment Buffer Overflow:        0
Read Segments Rcv'd:           0   Invalid Sequence Received:     0
Records Written:                0   Illegal Message Type Rcv'd:   0
Write Segments Rcv'd:           0   Invalid Transactions:          0
Control Messages Rcv'd:        0   Tape I/O Errors:               0
Segments Retransmitted:        0   Resource Errors:                0
```

This example shows the display generated by the SHOW TAPE command. Table 3–14 describes the fields.

Table 3-14 SHOW TAPE Display Fields

Field	Description
Seconds Since Zeroed	Number of seconds since counters were zeroed.
Solicit Messages Rcv'd	Number of Solicit Request messages received from clients since counters were last zeroed.
Solicit Responses Sent	Number of Solicit Response messages sent to clients since counters were last zeroed.
Connect Requests Rcv'd	Number of Connect Request messages received from clients.
Records Read	Number of tape records read by clients.
Read Segments Rcv'd	Number of tape segment read requests received from clients.
Records Written	Number of tape records written by clients.
Write Segments Rcv'd	Number of tape segment write requests received from clients.
Control Messages Rcv'd	Number of control messages received from clients (for example, Rewind, Write Tape Mark, and so forth).
Segments Retransmitted	Number of segments retransmitted by clients.
Connect Failed, Bad Password	Number of connect failures caused by a client that failed to connect because of an invalid password.
Invalid Access Requested	Number of invalid access requests. A client attempted to connect to a service set to NO READERS.
Connection Count Exceeded	Number of times a client attempted to connect to a service with the maximum number of connections.

(continued on next page)

SHOW TAPE

Table 3-14 (Cont.) SHOW TAPE Display Fields

Field	Description
Segment Buffer Overflow	A client attempted to transfer too much data for the negotiated tape buffer size.
Invalid Sequence Received	Number of times an invalid sequence number was received. The sequence number of the request is not in the valid range.
Illegal Message Type Rcv'd	Number of times a client sent a message type that the server does not recognize.
Invalid Transactions	Number of invalid transactions. A client failed to complete a tape operation. The transaction is therefore invalid.
Tape I/O Errors	Number of tape I/O errors.
Resource Errors	Number of errors caused by lack of resources.

UNBIND

Deletes the virtual device created by a BIND command and terminates the connection to the associated remote service.

Format

```
UNBIND [VDK1[:]]
```

Parameters

[VDK1[:]]

Optionally specifies the name of the virtual device. By default, VDK1 is assumed.

Description

You can use the same remote service to perform multiple updates on an InfoServer system (for example, you might use the service UPD_DRV to update VXT software and then install new functions). However, you must enter the UNBIND command after each update operation to flush data that has been cached from the previous one. You then enter the BIND command to reconnect to the UPD_DRV service before you perform the next update.

For detailed information on performing network installations and updates, refer to Section 4.13.

Example

```
InfoServer> UNBIND  
%ESS-I-VDDELETE, Virtual device VDK1: deleted.
```

This command deletes the device VDK1 and terminates connection to the associated service.

UNLOAD

UNLOAD

Rewinds and unloads an InfoServer tape device; unloads some magneto-optical (MO) devices.

Format

```
UNLOAD device[:]
```

Parameter

device[:]

Specifies a valid InfoServer tape device, as defined in Table 2-1, or a magneto-optical device.

Description

The UNLOAD command rewinds and unloads the specified tape. The command also unloads some MO devices.

Example

```
InfoServer> UNLOAD TP8:
```

This command rewinds and unloads the TP8 tape.



UPDATE FUNCTIONS

Installs one or more new functions.

Format

```
UPDATE FUNCTIONS src_device[:] [dest_device[:] ]
```

Parameters

src_device[:]

Specifies the drive containing the new function compact disc.

dest_device[:]

Optionally specifies the writable InfoServer destination device, which can be either an InfoServer-formatted disk or NVRAM (nonvolatile random-access memory). If you specify NVRAM, do not include the colon.

If you omit the destination device name, the InfoServer system uses, in order, one of the following:

- 1 NVRAM for InfoServer 1000 systems
- 2 The device from which the system booted, if the device is writable
- 3 The InfoServer-formatted disk with the lowest device number

Description

You use the UPDATE FUNCTIONS command to install new functions, which come on a special compact disc from Digital. The UPDATE FUNCTIONS command installs the functions from the compact disc onto the target device you specify.

Example

```
InfoServer> UPDATE FUNCTIONS DK8: DK1:  
%ESS-I-UPDATE, Update request completed successfully.
```

This command installs the function supplied on a function compact disc inserted in the DK8 drive.

UPDATE SYSTEM

UPDATE SYSTEM

Updates the InfoServer operational software.

Format

```
UPDATE SYSTEM src_device[:] [dest_device[:] ]
```

Parameters

src_device[:]

Specifies the drive containing the new InfoServer software compact disc, or a hard drive and partition name. This parameter must specify a valid InfoServer drive, as defined in Table 2–1.

dest_device[:]

Optionally specifies the destination device on which the new software is installed. This parameter must specify either a valid InfoServer disk device, as defined in Table 2–1, or FLASH memory (InfoServer 1000 systems only). If you specify FLASH, do not include a colon.

If you omit the destination device name, the InfoServer system uses, in order, one of the following:

- 1 FLASH for InfoServer 1000 systems
- 2 The device from which the system booted, if the device is writable
- 3 The InfoServer-formatted device with the lowest device number

Description

You use the UPDATE SYSTEM command to update the InfoServer software. The InfoServer software is preinstalled on the internal read/write device, which is a disk for the InfoServer 100 and 150 systems and FLASH for InfoServer 1000 systems. If you receive software updates on compact discs, you can use the UPDATE SYSTEM command to install the updated software on the internal read/write device.

You must specify a source InfoServer compact disc drive as the first parameter for the UPDATE SYSTEM command. The second parameter is the destination device.

When you specify **FLASH** as the destination device, the flash burner program displays the current and update contents of the **FLASH** image and requests user confirmation of the update. This display consists of the following fields:

Field	Contents
Segment	Logical segment number (hex)
Size	Size of the segment in bytes (hex)
Version	Segment header version (hex)
Maj.Rev.	Major version of the segment code (hex)
Min.Rev.	Minor version of the segment code (hex)
Pat.Rev.	Patch version of the segment code (hex)
Time	Time-stamping of the segment code (hex seconds since 1970.0)
Name	Name of the segment

Unless the console diagnostics routines are also being updated, the update function changes only the InfoServer code and help file, segments 4 and 5. The version information for these two segments should agree with that shown in the Cover Letter.

During the update, the flash burner program displays progress messages on both the console and the InfoServer 1000 light-emitting diodes (LEDs). The LEDs show a code that should be read from right to left, excluding the power LED. At the end of the procedure, the flash burner forces a console diagnostic startup by setting the “corrupt bit,” which causes the diagnostics to flush all current console state and execute the powerup diagnostic sequence. Ignore the resulting “?? CRPT - Corrupt bit is set” message when this restart occurs.

Examples

1. InfoServer> **UPDATE SYSTEM DK2:**
%ESS-I-COPIED, Copy operation completed successfully.

This command uses the InfoServer software on the DK2 device to update the internal read/write device.

UPDATE SYSTEM

2. InfoServer> UPDATE SYSTEM DK2: FLASH

---InfoServer 1000 FLASH ROM Update Program V1.6---

Current Contents of FLASH:

Segment	Size	Version	Maj.Rev.	Min.Rev.	Pat.Rev.	Time	Name
00000001	00004000	00000001					
00000002	0001C000	00000001					
00000003	00003000	00000002	00000002	00000226	00000000	2B824DBB	EXT_HEADER
00000004	0003D000	00000002	00000010	00000003	00000000	2B93A0F1	SYSLOCS
00000005	0000F000	00000002	00000010	00000003	00000000	2B93A0F1	HELP.MEM

Update Contents of FLASH:

Segment	Size	Version	Maj.Rev.	Min.Rev.	Pat.Rev.	Time	Name
00000001	00004000	00000001					
00000002	0001C000	00000001					
00000003	00003000	00000002	00000002	00000226	00000000	2B824DBB	EXT_HEADER
00000004	0003E000	00000002	00000010	00000004	00000000	2B94D99B	SYSLOCS
00000005	0000F000	00000002	00000010	00000004	00000000	2B94D99B	HELP.MEM

Flash image size (HEX): 00050000 Starting offset (HEX): 00020000

---CAUTION---

EXECUTING THIS PROGRAM WILL CHANGE YOUR CURRENT INFOSERVER ROM IMAGE

Do you really want to continue [Y/N] ? : **Y**

DO NOT ATTEMPT TO INTERRUPT PROGRAM EXECUTION!
DOING SO WILL RESULT IN LOSS OF OPERABLE STATE!

The program will take one minute at most.

led codes display info

0000 0nnn	-	in process of erasing	FEPROM block nnn
0000 1nnn	-	in process of programming	FEPROM block nnn
0001 0nnn	-	in process of verifying	FEPROM block nnn

DO NOT POWER DOWN OR TOUCH BREAK, OR YOU WILL DAMAGE THE CPU MODULE !!!!

!!!! THE SYSTEM WILL THEN DO A POWERUP RESTART at the console !!!!

!!!! OTHERWISE, POWER CYCLE THE BOX AFTER ALL LEDS ARE LIT !!!!

Erasing Block 00000005

Programming Block 00000005

Verifying Block 00000005

Erasing Block 00000006

Programming Block 00000006

Verifying Block 00000006

Erasing Block 00000007

Programming Block 00000007

Verifying Block 00000007

UPDATE COMPLETE -- IGNORE THE '?? CRPT - Corrupt bit is set' MESSAGE

?? CRPT - Corrupt bit is set

InfoServer 1000 V1.0-226-V3.7 17-FEB-1994 12:43:38.00

08-00-2B-A0-C9-8B ThinWire

4MB

| |
#####

OK

83 BOOT SYS
-FLASH

DEC InfoServer 1000 V3.2

Copyright (c) 1990, 1991, 1992, 1994 Digital Equipment Corp.

%ESS-I-INITDISK, Disk initialization complete, 6 devices found

%ESS-I-CRASHFND, Crash partition located on DK2

%ESS-I-RESTORED, Restore completed successfully from NVRAM

Enter Password:

This command uses the InfoServer software on device DK2 to update the FLASH device on an InfoServer 1000 system.

UPDATE VXT

Installs all X terminal files on the specified destination disk.

Format

```
UPDATE VXT src_device[:] [dest_device[:] ]
```

Parameters

src_device[:]

Specifies the drive containing VXT distribution compact disc.

dest_device[:]

Optionally specifies the destination device to which the files are copied. This parameter must specify a valid InfoServer disk, as defined in Table 2-1.

If you omit the destination device name, the InfoServer system uses, in order, one of the following:

- 1 The disk from which the system booted, if the disk is writable
- 2 The InfoServer-formatted device with the lowest device number

Description

You use the **UPDATE VXT** command to install X terminal files, which come on a special compact disc from Digital. The **UPDATE VXT** command installs the functions from the compact disc onto the target disk you specify.

Example

```
InfoServer> UPDATE VXT DK2: DK1:
...Beginning installation of VXT files
...Attempting to reserve disk space for installation
.
.
.
Do you want to purge older versions of this software [Yes]? Return
.
.
.
%ESS-I-FILPUR, 16 files purged.
%ESS-I-UPDATE, Update request completed successfully.
```

The commands in this example install X terminal files on device DK1 and purge older versions on that device.

VERIFY

Validates the on-disk structure of a device formatted with the INITIALIZE command.

Format

```
VERIFY device[:] {NOREPAIR | REPAIR}
```

Parameter

device[:]

Specifies a valid InfoServer disk device, as defined in Table 2–1.

Options

NOREPAIR (D)

Lists errors but does not attempt to repair them.

REPAIR

Lists errors and corrects them if possible.

Description

The VERIFY command validates the on-disk structure of the specified device. To preserve data integrity, InfoServer software does not permit VERIFY REPAIR operations unless the InfoServer state is set OFF. This check prevents remote virtual disk operations from interfering with local disk operations.

Example

```
InfoServer> VERIFY DK1:  
%ESS-I-REWIND, Verify completed successfully.
```

This command validates the on-disk structure of the DK1 disk.

ZERO ALL

ZERO ALL

Resets all InfoServer internal counters.

Format

ZERO ALL [COUNTERS]

Description

The ZERO ALL command sets to 0 all internal InfoServer counters.

Example

```
InfoServer> ZERO ALL
```

This command sets to 0 all counters associated with the operation of the InfoServer system.

ZERO ETHERNET

Resets all Ethernet internal counters.

Format

ZERO ETHERNET [COUNTERS]

Description

The **ZERO ETHERNET COUNTERS** command resets all Ethernet internal counters kept by the InfoServer system. You can display these counters with the **SHOW ETHERNET** command.

Example

```
InfoServer> ZERO ETHERNET COUNTERS
```

This command sets to 0 all counters associated with the operation of the Ethernet data link and the LASTport protocol.

ZERO LAT

ZERO LAT

Resets the LAT terminal server internal counters kept by the InfoServer system.

Format

ZERO LAT [COUNTERS]

Description

The ZERO LAT COUNTERS command resets all internal LAT terminal server counters kept by the InfoServer system. You can display the counters with the SHOW LAT command.

Example

```
InfoServer> ZERO LAT
```

This command sets to 0 all the counters that the InfoServer keeps for the LAT protocol.

ZERO MOP

Resets the maintenance operation protocol (MOP) counters.

Format

ZERO MOP [COUNTERS]

Description

The **ZERO MOP COUNTERS** command resets all internal MOP counters kept by the InfoServer system. You can display the counters with the **SHOW MOP** command.

Example

```
InfoServer> ZERO MOP
```

This command sets to 0 all the counters that the InfoServer keeps for the MOP protocol.

ZERO SERVER

ZERO SERVER

Resets the InfoServer system's internal counters.

Format

ZERO SERVER [COUNTERS]

Description

The **ZERO SERVER COUNTERS** command resets all InfoServer counters by the InfoServer system for its own internal operations. You can display these counters with the **SHOW SERVER** command.

Example

```
InfoServer> ZERO SERVER
```

This command resets the counters that the InfoServer system keeps for monitoring its internal operations, including the number of network blocks read and written, and CPU utilization statistics.

ZERO TAPE

Resets tape counters.

Format

ZERO TAPE [COUNTERS]

Description

The **ZERO TAPE COUNTERS** command resets all counters kept by the InfoServer tape protocol. You can display these counters with the **SHOW TAPE** command.

Example

```
InfoServer> ZERO TAPE
```

This command resets the tape protocol counters.

Advanced Operations

The standard InfoServer system provides transparent access to compact discs, without the need to enter any InfoServer management commands. However, for some customized configurations you might need to set up the system by using InfoServer commands.

This chapter describes some of the advanced operations you can perform by using InfoServer commands. Each section provides examples. The chapter describes how to perform the following operations:

- Serve regularly updated compact discs
- Assign passwords to protect compact discs
- Serve media under several service names to allow access by different operating systems
- Create and serve partitions to make use of open space on the internal read/write disk
- Serve external read/write disks
- Back up read/write data locally or remotely
- Defragment an InfoServer disk by using **BACKUP** and **RETRIEVE** commands
- Replicate an InfoServer disk
- Make downline loadable images available to clients
- Configure X terminals to use the InfoServer system
- Enforce network licensing limits for devices
- Record compact discs
- Perform installations and updates over the network

4.1 Serving Regularly Updated Compact Discs

By default, a running InfoServer system automatically serves compact discs to clients when you insert the discs. It also deletes services automatically when you remove compact discs. The system provides access to the current set of compact discs by their volume label.

Access by volume label is convenient for compact discs that remain in the InfoServer system on a permanent basis. This method is also useful for temporary compact discs that will not be updated.

However, you might want to use a different method for compact disc subscriptions where information is updated regularly. When you remove an old disc and insert the updated copy, the automatically assigned service name usually changes because the updated media has a new volume label. For these cases, you may want to assign a single service name to the compact disc drive.

When you assign a single service name to a disc drive, clients can continue to use that name for connections when you insert a new disc. With a single service name, clients avoid the need to learn the volume labels of each new disc inserted.

To provide a fixed service name, follow these steps:

- 1 Assign the service name to a particular device.
- 2 Save the name, so it remains in effect whenever the InfoServer system reboots.

Example

```
InfoServer> CREATE SERVICE CONDIST FOR DK2: CLASS ODS_2 WRITERS 0  
%ESS-I-CREATED, Create service completed successfully.  
InfoServer> SAVE  
%ESS-I-SAVED, Save completed successfully to DK1:  
InfoServer>
```

In this example, the InfoServer manager enters the service name **CONDIST** for an InfoServer compact disc drive that will serve Digital's consolidated distribution software disc. When a new compact disc is inserted, users can continue to connect to the service **CONDIST** instead of having to learn the new volume label.

4.2 Assigning Passwords to Protect Compact Discs

By default, the InfoServer system automatically makes every inserted compact disc available to all client systems on the LAN. The InfoServer system creates the service for each compact disc and uses default values for service-related options such as password protection. By default, password protection is off.

In some cases, you might want to restrict access to information on compact discs by assigning a password. To provide password protection for compact discs, follow these steps:

- 1 Disable the automatic serving feature for the selected compact disc, using the command `SET DEVICE AUTOMOUNT` disabled.
- 2 Assign a service name and password for the selected compact disc.
- 3 Save the service name and password, so they remain in effect whenever the InfoServer system reboots.

Example

```
InfoServer> SET SERVER AUTOMOUNT DISABLED
%ESS-I-SET, Set operation completed successfully.
InfoServer> CREATE SERVICE SENSITIVE_INFO FOR DK2: PASSWORD
Password: SECRET (not echoed)
Verification: SECRET (not echoed)
%ESS-I-CREATED, Create service completed successfully.
InfoServer> SAVE
%ESS-I-SAVED, Save completed successfully to DK1:
InfoServer>
```

In this example, the InfoServer manager assigns the service name `SENSITIVE_INFO` and the password `SECRET` to the compact disc in the DK2 drive.

4.3 Serving Media Under Several Names

The InfoServer system and host clients use protocols that allow for redundant virtual devices to be served on the LAN with identical service names. The InfoServer system also allows a single virtual devices to be served several times under several different names.

You might want to provide several different names for the same virtual disk, for the convenience of users. You might also want to make the same media accessible to more than one operating system. To assign several names to a virtual disk, follow these steps:

Advanced Operations

4.3 Serving Media Under Several Names

- 1 Create several services with different names or service classes, all for the same device.
- 2 Save the services, so the names and classes remain in effect whenever the InfoServer system reboots.

Example

```
InfoServer> CREATE SERVICE RAW_DATA FOR DK2: CLASS ODS_2
%ESS-I-CREATED, Create service completed successfully.
InfoServer> CREATE SERVICE DATA_FROM_EXPERIMENT_2 FOR DK2: CLASS ODS_2
%ESS-I-CREATED, Create service completed successfully.
InfoServer> CREATE SERVICE RAW_DATA FOR DK2: CLASS ULTRIX
%ESS-I-CREATED, Create service completed successfully.
InfoServer> SAVE
%ESS-I-SAVED, Save completed successfully to DK1:
InfoServer>
```

In this example, the InfoServer manager assigns three aliases to the compact disc in the DK2 drive. The first two services are accessible from an OpenVMS system, and the third from an ULTRIX system. This action assumes that the information on the disc is in a format that each operating system can read. Notice that the same name can be reused under different service classes.

4.4 Creating and Serving Partitions

InfoServer 100 and 150 systems use an internal read/write disk to store InfoServer parameters, configuration, and operational software. Because these systems use the disk for their operations, these systems normally do not make the disk available as a whole to the LAN.

The systems use approximately 5000 to 10,000 disk blocks of the internal disk, depending on how many services are saved. You can make the remaining free disk blocks available to clients for general use, without interfering with the InfoServer data on the disk.

To make the remaining space available, you create partitions. You can create partitions on any disk that is initialized as an InfoServer disk.

To make read/write partitions available, follow these steps:

- 1 Create partitions of the desired size.
- 2 Create services for each partition in the proper namespace, with the appropriate read/write access and protection.
- 3 Save the services, so they are available whenever the InfoServer system reboots.

Example

In the following example, the InfoServer manager creates three partitions to serve to the LAN network.

```
InfoServer> CREATE PARTITION DK1:ONLINE_HELP BLOCKS 20000
%ESS-I-CREATED, Create partition completed successfully.
InfoServer> CREATE SERVICE ONLINE_HELP FOR DK1:ONLINE_HELP
CLASS ODS 2 WRITER 0
%ESS-I-CREATED, Create service completed successfully.
InfoServer> CREATE SERVICE HELP_UPDATE FOR DK1:ONLINE_HELP
CLASS ODS 2 WRITER 1 PASSWORD
_Password: SECRET (not echoed)
_Verification: SECRET (not echoed)
%ESS-I-CREATED, Create service completed successfully.
InfoServer> CREATE PARTITION DK1:DOS_STORAGE1 BLOCKS 50000
%ESS-I-CREATED, Create partition completed successfully.
InfoServer> CREATE PARTITION DK1:DOS_STORAGE2 BLOCKS 50000
%ESS-I-CREATED, Create partition completed successfully.
InfoServer> CREATE SERVICE DOS_STORAGE FOR DK1:DOS_STORAGE1
CLASS V2.0 WRITER 1
%ESS-I-CREATED, Create service completed successfully.
InfoServer> CREATE SERVICE DOS_STORAGE FOR DK1:DOS_STORAGE2
CLASS V2.0 WRITER 1
%ESS-I-CREATED, Create service completed successfully.
InfoServer> SAVE
%ESS-I-SAVED, Save completed successfully to DK1:
InfoServer>
```

The first partition is used by OpenVMS clients and has two service names assigned. The first service is for read-only users to access online help. The second service is for the LAN network manager to gain write access to the same partition, in order to update online help.

The last two partitions are used by MS-DOS clients running PATHWORKS. Notice that the PATHWORKS product uses scratch disk storage in the V2.0 service class, not the MS-DOS service class.

4.5 Serving an External Read/Write Disk

You can add compact discs, read/write disks, and tapes to the InfoServer system. The server handles external devices the same way as internal devices. For example, external compact discs are automatically served to clients when the discs are inserted.

For read/write drives, the disk is normally unformatted. Because an unformatted disk does not have a volume label, the InfoServer system does not automatically serve it to the LAN network.

Advanced Operations

4.5 Serving an External Read/Write Disk

To make the disk accessible, follow these steps:

- 1 Create a service in the proper namespace, with other desired settings.
- 2 Save the service so it is always available whenever the InfoServer system reboots.

Example

```
InfoServer> CREATE SERVICE RZ56 FOR DK12: CLASS ODS_2 WRITERS 1
%ESS-I-CREATED, Create service completed successfully.
InfoServer> SAVE
%ESS-I-SAVED, Save completed successfully to DK1:
InfoServer>
```

After the InfoServer manager enters these commands, a client could bind to the service name RZ56, initialize the disk with an ODS-2 on-disk structure, mount the disk, and use the entire disk as if it were a locally attached RZ56 disk.

4.6 Backing Up Read/Write Data

Because the InfoServer system provides access to read/write storage, you might need to periodically back up the stored information. Backing up data allows you to restore information if the system has a disk failure, you replace an InfoServer unit, or any similar interruption occurs.

There are two methods available for backing up InfoServer data:

- If you have added a second read/write drive to the InfoServer system, you can perform the backup operation locally by using InfoServer commands.
- You can also back up InfoServer disks to a remote client system, using the normal disk-access commands for your operating system to access the InfoServer system.

The following sections describe how to perform local and remote backup operations.

4.6.1 Backing Up Data Locally

If you have added a read/write drive to your InfoServer system, you can use the InfoServer commands BACKUP and RETRIEVE to back up data to, and retrieve data from, that disk (see Chapter 3). For a local backup operation to succeed, the target disk must be only large enough to contain all the data on the source disk plus a small amount of overhead.

Because the **BACKUP** command initializes the target device, you cannot use the command to add partitions to an already formatted device. If the destination device contains sufficient space, you can use the **COPY** command as follows:

- 1** Determine the size of the disk being backed up.
- 2** Initialize the external disk, so it can be used to create partitions.
- 3** Create the partition of the appropriate size.
- 4** Use the InfoServer **COPY** command to save the data.

To restore the data, you would use the same **COPY** command but specify the partition as the source and the disk as the target.

Example

```
InfoServer> SHOW DEVICE DK1:
```

Device Name	Device State	Device Type	Device Address	Dev. Size/Record Num.	Volume Label	Device Char
DK1:	On	Hard Disk	A/001	204864	UNKNOWN	

```
InfoServer> INITIALIZE DK12:
```

```
InfoServer> CREATE PARTITION DK12:SAVE_PARTITION BLOCKS 204864
```

```
%ESS-I-CREATED, Create partition completed successfully.
```

```
InfoServer> COPY DK1: DK12:SAVE_PARTITION
```

```
%ESS-I-COPIED, Copy operation completed successfully.
```

```
InfoServer>
```

In this example, the InfoServer manager backs up a smaller, internal **RZ** disk to a larger, external **RZ56** disk. The manager initializes the **RZ56** drive as device **DK12** and then creates a partition on the **RZ56** to match the storage size of the internal **RZ** disk. The backup operation saves all system configurations, parameters, and operational software, as well as any partitions created.

4.6.2 Backing Up Data Remotely

You might want to back up data to a remote client system under one of the following conditions:

- You do not have additional read/write disks on your InfoServer system.
- You want to back up data to some other media, such as magnetic tape.

Advanced Operations

4.6 Backing Up Read/Write Data

Example

This example shows how to back up data to an OpenVMS system. Here are the basic steps:

- 1 On the InfoServer system, make the entire disk available through a service.
- 2 On the OpenVMS system, access the disk as though the online disk structure were unknown.
- 3 Perform the backup operation.

On the InfoServer system:

```
InfoServer> CREATE SERVICE BACKUP FOR DK1: CLASS ODS_2 WRITERS 0 PASSWORD
_Password: SECRET (not echoed)
_Verification: SECRET (not echoed)
InfoServer>
```

Then, on the OpenVMS system:

```
$ MCR ESS$LADCP
LADCP> BIND/PASSWORD=SECRET BACKUP
%LADCP-I-BIND, service bound to logical unit DAD$BACKUP (_DAD4:)
LADCP> EXIT
$ MOUNT/FOREIGN/NOWRITE DAD$BACKUP:
%MOUNT-I-MOUNTED,          mounted on _DAD4:
$ MOUNT/FOREIGN DKA200:
%MOUNT-I-MOUNTED,          mounted on _DKA200:
$ BACKUP/PHYSICAL DAD$BACKUP: DKA200:
```

Note that you could use any other operating system to perform this backup operation, as long as that system has client software to access the InfoServer system. Simply use the appropriate commands for your operating system in place of the OpenVMS commands in this example.

4.7 Defragmenting an InfoServer Disk

As partitions are created and deleted on an InfoServer-formatted disk, the disk can become fragmented. However, the file system can reuse deleted partitions for requested new partitions provided that the deleted partitions are large enough. Because partitions are contiguous, a requested new partition cannot be larger than the largest deleted partition or than the largest segment of remaining free space on the disk. The command `SHOW PARTITIONS DKn: FULL` shows the sizes of both deleted and currently allocated partitions.

Defragmenting a disk requires another disk on which to stage the data during the operation. Tape devices are not currently supported for BACKUP operations. To defragment the disk, you save its contents to a staging disk and then immediately restore them using the RETRIEVE command. Remember to issue the SAVE command to save the restored services.

For example, to back up the system disk DK1 to the backup disk DK15 and to defragment the system disk, you enter the following commands:

```
InfoServer> SET SERVER STATE OFF
InfoServer> BACKUP DK1 DK15
InfoServer> RETRIEVE DK15 DK1
InfoServer> SET SERVER STATE ON
InfoServer> SAVE
```

4.8 Replicating an InfoServer Disk

You can use the BACKUP and RETRIEVE commands to move all the partitions from one disk to another. For example, suppose you want to replace the InfoServer 150 system's internal boot disk with a larger device and that hard disk DK15 is available to stage data during the exchange. You can follow these steps:

1 Back up the boot device:

```
InfoServer> SET SERVER STATE OFF
InfoServer> BACKUP DK1 DK15
InfoServer> SHUTDOWN Y
```

2 Turn off the system and replace the internal disk with a larger device.

3 Insert the InfoServer kernel compact disc in the internal compact disc drive and turn on the system. The system reboots from the compact disc.

4 Log in to the InfoServer system and restore the backup to the new disk:

```
InfoServer> SET SERVER STATE OFF
InfoServer> RETRIEVE DK15 DK1
```

5 Restore the old service database from the restored copy of the boot device. The services for the partitions on DK1 have been restored by the RETRIEVE command.

```
InfoServer> RESTORE DK1
InfoServer> SET SERVER STATE ON
```

6 Save the restored services back to DK1.

```
InfoServer> SAVE
```

4.9 Making Downline Loadable Images Available to Clients

To make system software and other downline loadable images available to clients, follow these steps:

- 1 Determine the size of the downline loadable image.
- 2 Create a partition on the InfoServer system to receive the image.
- 3 Create a service to access the partition from the client system.
- 4 Copy the image to the partition.
- 5 Modify the partition to be a maintenance operation protocol (MOP) partition.
- 6 Make sure that the MOP downline loading feature is enabled.

Example

This example shows the steps for downline loading a DECserver 200 that requests a file named PR0801ENG.SYS. The example uses OpenVMS as the client system that has the downline loadable image. You could use any other operating system that has client access to the InfoServer system; simply use the appropriate commands for your operating system in place of the OpenVMS commands.

On the OpenVMS system currently performing downline loading, issue a **DIRECTORY** command to determine the size of the downline loadable file. For example:

```
$ DIRECTORY/SIZE MOM$LOAD:PR0801ENG.SYS
```

```
Directory SYS$COMMON:[MOM$SYSTEM]
```

```
PR0801ENG.SYS;1      378
```

From an InfoServer console terminal, enter the **CREATE PARTITION** command to set aside storage for the MOP downline loadable file. The partition name must be the same as the OpenVMS file name, but without the file type (which is the name requested by the system being downline loaded). Serve the partition to the LAN, so that the OpenVMS system can copy the downline loadable file to the partition. For example:

Advanced Operations

4.9 Making Downline Loadable Images Available to Clients

```
InfoServer> CREATE PARTITION DK1:PR0801ENG BLOCKS 378
%ESS-I-CREATE, Create partition completed successfully.
InfoServer> CREATE SERVICE MOP_UPDATE FOR DK1:PR0801ENG CLASS ODS_2
WRITERS 1 PASSWORD
_Password: SECRET (not echoed)
_Verification: SECRET (not echoed)
%ESS-I-CREATED, Create service completed successfully.
InfoServer>
```

On the OpenVMS client system, bind to the service under which the partition was served. Next, mount the device as a foreign device. Then copy the downline loadable file to the device connected to the partition.

```
$ RUN SYS$SYSTEM:ESS$LADCP
LADCP> BIND/WRITE/PASSWORD=SECRET MOP_UPDATE
%LADCP-I-BIND, service bound to logical unit DAD$MOP_UPDATE (_DAD3:)
LADCP> EXIT
$ MOUNT/FOREIGN DAD$MOP_UPDATE
%MOUNT-I-MOUNTED,          mounted on _DAD3:
$ COPY MOM$LOAD:PR0801ENG.SYS DAD$MOP_UPDATE:
$ DISMOUNT DAD$MOP_UPDATE
```

On the InfoServer console terminal, you might want to unserve the MOP partition to avoid possible corruption by other clients accidentally connecting to the MOP file. Then set the partition type to MOP and enable downline loading for the InfoServer system. For example:

```
InfoServer> DELETE SERVICE MOP_UPDATE FOR DK1:PR0801ENG CLASS ODS_2
InfoServer> SET PARTITION DK1:PR0801ENG MOP
InfoServer> SET SERVER MOP_ENABLED
InfoServer> SAVE
%ESS-I-MAVED, Save completed successfully to DK1:
InfoServer>
```

The InfoServer system is now capable of downline loading any system that requests the file PR0801ENG.

4.9.1 MOP Downline Loading by Ethernet Address

By using the MOP service class, you can set up the InfoServer system to answer MOP downline load requests by Ethernet address as well as by file name. The general procedure is as follows:

- 1 Create a partition containing the image you want the InfoServer to load (see Section 4.9).

Advanced Operations

4.9 Making Downline Loadable Images Available to Clients

2 For each system that will request this image, create for the partition a service in the MOP service class, using a service name of the form MOP\$nnnnnnnnnnnn, where nnnnnnnnnnnn is the system's hexadecimal Ethernet address.

3 Perform a SAVE operation.

As an example, if you have a VT1300 X terminal that is currently loading from a VAX host, you can free host resources by loading that terminal from an InfoServer system.

Follow these steps:

1 Determine the terminal's hardware address (for example, 08-00-2b-2c-bd-0c)

2 Create a MOP service and save the service.

```
InfoServer> CREATE SERVICE MOP$08002B2CBD0C FOR DK1:VXTLDR0130 CLASS MOP
InfoServer> SAVE
```

4.9.2 Automatic Installation of MOP Partitions

Some compact discs provide information that allows the InfoServer system to copy MOP images from the compact disc to partitions on a local hard disk. This mechanism provides two benefits. The first is improved performance. Because MOP files are located more quickly on an InfoServer-formatted read/write disk than on an initial system load (ISL) compact disc, downline loads are faster.

The second benefit is enhanced problem diagnosis. Because the InfoServer system cannot perform a DIRECTORY of MOP files located on an ODS-2 formatted compact disc, the system manager cannot determine which MOP files are present. Because InfoServer software automatically copies the MOP files to InfoServer partitions, the system manager can enter the InfoServer command SHOW PARTITIONS to display the special MOP partitions, which are flagged as MOP and TEMPORARY. When the compact disc is removed, the partitions are deleted.

4.10 Configuring X terminals

You can use InfoServer commands to optimize X terminal usage of InfoServer resources. The following example shows one of various ways to configure X terminals on your LAN. The example explains how to do the following:

- Install X terminal software from compact disc
- Ensure that the server is configured to load X terminal software
- Change the default disk on which X terminal partitions are created

- Change the maximum size of partitions that X terminals can create remotely
- Enable services that assist X terminals in establishing connections
- Perform a SAVE operation

Example

```
InfoServer> UPDATE VXT DK2: DK1: ①
_Password for protected data [default=VXT] 
%ESS-I-UPDATE, Update operation completed successfully.

InfoServer> SET SERVER MOP ENABLED ②
%ESS-I-SET, Set operation completed successfully.

InfoServer> SET SERVER REMOTE DEVICE DK8:,DK9: ③

InfoServer> SET SERVER EXTENSION LIMIT 60000 ④
%ESS-I-SET, Set operation completed successfully.

InfoServer> SET SERVER LAT RESPONDER ENABLED ⑤
%ESS-I-SET, Set operation completed successfully.

InfoServer> SAVE ⑥
%ESS-I-MAVED, Save completed successfully to DK1:
InfoServer>
```

The commands perform the following operations:

- ① This command moves the X terminal software from the distribution compact disc (inserted in drive DK2) to the internal read/write disk, where the software is stored in the correct InfoServer format.
- ② This command ensures that the InfoServer system is configured to load the X terminals by using MOP.
- ③ This command disables device DK1 for use by X terminals and enables devices DK8 and DK9. The example assumes that external read/write disks have been added to the InfoServer system as devices DK8 and DK9. and that these devices have been formatted with the InfoServer INITIALIZE command.
- ④ This command modifies from 50,000 to 60,000 blocks the maximum partition size that any single X terminal can create.
- ⑤ This command enables the LAT Responder function. This function enables X terminals to complete LAT terminal server connections quickly.
- ⑥ Finally, settings are made permanent with the SAVE command.

4.11 Enforcing Network License Limits for Devices

Information providers frequently offer licenses to use their compact disc databases based on a number of simultaneous users. The InfoServer system can assist in license enforcement.

Because the InfoServer automount function allows unrestricted read access to a device by default, you must disable automount for any device that contains a service to which you want to limit access. If you want to restrict access to all the devices on the server, you can disable automount for the entire server by using the command **SET SERVER AUTOMOUNT DISABLED**.

However, if you want to restrict access to a specific device while permitting automount in general, you can disable automount for that device by using the command **SET DEVICE AUTOMOUNT DISABLED**.

Once automount is disabled for the specific device, you must create a new service for the device, specifying a reader limit that matches your license. Remember to perform a **SAVE** operation to keep your changes.

For example, suppose you have a compact disc labeled **CENSUS** for which you have a 5-user simultaneous network license. The search software runs under the DOS system, which uses the class name **V2.0** to access InfoServer devices. You have decided to allocate the compact disc drive **DK7** to this disc. To enforce the license limit, follow these steps:

- 1 **Disable automount for the DK7 drive:**

```
InfoServer> SET DEVICE DK7: AUTOMOUNT DISABLED
```

- 2 **Insert the compact disc in DK7 and create a service that limits access to 5 readers:**

```
InfoServer> CREATE SERVICE CENSUS FOR DK7: CLASS V2.0 READERS 5
```

- 3 **Perform a **SAVE** operation:**

```
InfoServer> SAVE
```

Only five clients can now access the service **CENSUS** simultaneously.

4.12 Compact Disc Recorder (CD-R) Function

InfoServer CD-R software enables you to record compact discs using an InfoServer system and hard drive in combination with a compact disc recorder and optional formatting program. The next sections describe component setup and recording procedures.

4.12.1 Component Setup

To prepare components for a recording session, Configure the InfoServer system, staging disk, recorder, and compact disc drive as shown in Figure 4-1 and set the recorder switches for recording as described in the owner's manual.

Figure 4-1 Recording Configuration

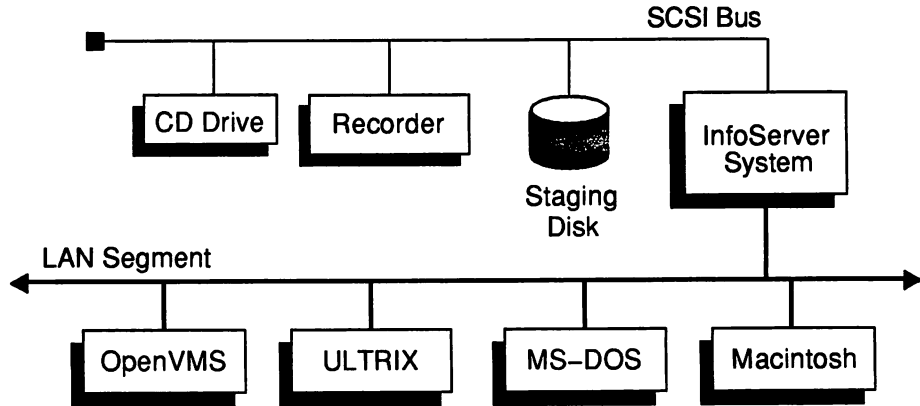

You can verify that the recorder is ready by entering the following command on the InfoServer system:

```
InfoServer> SHOW RECORDER FULL
```

If the recorder is ready, the system displays information like the following:

```
Device Name:      DK2:
Manufacturer:     SONY
Mfgr's Model:    CDW-900E
Firmware Rev:    1.13
Encoder Status:  Ready
Writer 0 Status: Ready           CD Capacity:    682752000
```

If the display shows that the recorder is not ready, check that all components are correctly connected and that the recorder switches are set for recording.

Advanced Operations

4.12 Compact Disc Recorder (CD-R) Function

4.12.2 Recording Procedures

To perform a recording operation, follow these steps:

- 1 On the client system, prepare the data you want to record, observing the following requirements:
 - The capacity of the staging disk or InfoServer partition must be smaller than that of the target CD-ROM (less than 550 MB for a 63-minute CD-ROM or less than 650 MB for a 74-minute CD-ROM). Remember that the recording process involves overhead such as Table of Contents (TOC), lead-in and lead-out.
 - For native format, you must record the entire staging disk or InfoServer partition: *do not specify the RECORD command's SIZE option*. For ISO 9660 or High Sierra Group (HSG) format, the container file generated by a formatter must be contiguous. You can use the **SIZE** option to specify the exact size of the container file and thereby save recording time.
 - The staging disk must be dismounted before starting the recording process. On OpenVMS systems, perform an **ANALYZE/DISK/REPAIR** operation on the disk before dismounting it.
- 2 Log in to the InfoServer system and create on the staging disk a partition large enough for the data to be recorded (minimum recordable size is 5,120,000 bytes, or 10,000 blocks).

To ensure data integrity on the staging disk, specify the **ERASE** option when creating the partition. For example, to create a 1,500,000 block partition called **VIR_CD** on **DK5**, you would enter the following command:

```
InfoServer> CREATE PARTITION DK5:VIR_CD BLOCKS 1500000 ERASE
%ESS-I-CREATED, Create partition completed successfully.
```

- 3 Create a service for the partition, specifying the appropriate service class. For example:

```
InfoServer> CREATE SERVICE ULTRIX_DATA FOR DK5:VIR_CD CLASS ULTRIX
%ESS-I-CREATED, Created service ULTRIX_DATA [ULTRIX].
%ESS-I-CREATED, Create service completed successfully.
```

- 4 Mount the service and format the partition for the desired file system. Refer to your client's user documentation for instructions.
- 5 Copy the data to the staging disk partition and verify the data.

For native format:

- a Copy the data using the client's native copy command.
- b Request a directory to verify data and file attributes.

Advanced Operations

4.12 Compact Disc Recorder (CD-R) Function

For ISO 9660 or High Sierra File System (HSFS) format:

- a Use a formatter to copy the data to the partition. Typically, the formatter displays the size of the data in bytes when the copy operation completes.
- b Dismount the original service on the client and optionally delete the service on the InfoServer system.
- c Create a new service for the partition, specifying the ISO (or HSFS) and CONTAINER options. For example:

```
InfoServer> CREATE SERVICE ISO_DATA FOR DK5:VIR_CD CLASS ISO CONTAINER
%ESS-I-CREATED, Created service ISO DATA [ISO_9660].
%ESS-I-CREATED, Create service completed successfully.
```

This command causes the service to point to the beginning of the ISO 9660 or HSFS data rather than to the beginning of the partition. Because the container file is the **virtual compact disc**, it must contain only the data to be recorded. Do not attempt to write additional data to the partition.

- d Mount the new service and request a directory to verify data and file attributes. Note that file names are displayed according to the ISO 9660 standard (upper case, underscores substituted for spaces, and so forth).
- 6 Enter a RECORD command specifying the staging disk partition as the source and the recorder as the destination device.

For example, if the data is to be recorded in native format, enter a command like the following:

```
InfoServer> RECORD DK5:ULTRIX_DATA DK2: TIME 2 SPEED 2
```

By default, the data is recorded in the client's native file format (in this case, ULTRIX).

If the data is to be recorded in ISO 9660 or HSFS format, you must specify the ISO or HSFS option. (You can also specify the size of the data shown by the formatter's copy operation.) For example:

```
InfoServer> RECORD DK5:ISO_DATA DK2: TIME 2 SPEED 2 ISO SIZE 651405312
```

Depending on the device, the system displays messages like the following:

Advanced Operations

4.12 Compact Disc Recorder (CD-R) Function

```
%ESS-I-SERCHIMG, Searching for image start...
%ESS-I-SERCHWRT, Searching for ready writers...
%ESS-I-12CMDISC, Detected a new 12cm disc in Writer ID 0.
- The disk capacity is 74 Minutes, 5 Seconds, 0 Frames.
- Estimated recording time at 2x speed is 38 Minutes, 22 Seconds, 72 Frames.
%ESS-I-STARTWRT, Starting write on Writer ID 0.
%ESS-I-TRACKWRT, Writing track #1.
- Time to write track #1 is 35 Minutes, 20 Seconds, 34 Frames.
- 2 Minutes elapsed, recording continuing...
- 4 Minutes elapsed, recording continuing...
.
.
.
```

4.13 Performing Network Installations and Updates

InfoServer managers can update an InfoServer system from a compact disc attached to another InfoServer system on the local area network (LAN). All update operations (FUNCTION, MOP, SYSTEM, and VXT) are supported using the new BIND and UNBIND commands and the existing UPDATE command.

4.13.1 Connecting to a Remote Service

You use the BIND command to connect to the specified ODS-2 service and create the virtual device VDK1 for that service. The device is used as if it were a locally attached compact disc drive. Note that the server containing the remote service must be in the same LASTport group as the server on which you enter the BIND command. After a bind operation completes, the VDK1 device appears in the SHOW DEVICE display.

You can specify an optional password to access password-protected services by entering a BIND command in the following format:

```
BIND ODS-2-service-name [PASSWORD optional-password ]
```

For example:

```
InfoServer> BIND UPD_DRV PASSWORD RAINMAN
%ESS-I-VDCREATE, Virtual device VDK1: successfully created.
%ESS-I-VDCONN, VDK1: connected to service: UPD_DRV
```

```
InfoServer> SHOW DEVICE VDK1:
```

Device Name	Device State	Device Type	Device Address	Dev. Size/ Record Num.	Volume Label	Device Char
VDK1:	On	Virtual Disk	N/A	962	UPD_DRV	RO

4.13.2 Performing Updates Using a Remote Service

Once you have connected to a service, you can enter any **UPDATE** command, specifying **VDK1** as the source device. The device must be specified as the source device because it is read-only. In the following example, the **VDK1** device is connected to a service containing an InfoServer function access compact disc:

```
InfoServer> UPDATE FUNCTION VDK1: DK2:  
%ESS-I-UPDATE, Update operation completed successfully.
```

4.13.3 Disconnecting from a Remote Service

After the update operation completes, you can use the **UNBIND** command to delete the virtual device and terminate the connection to the remote service. When the unbind operation completes, the virtual device **VDK1** no longer appears in the **SHOW DEVICE** display.

You can use the same remote service to perform multiple updates on an InfoServer system (for example, you might use the service **UPD_DRV** to update **VXT** software and then install new functions). However, you must enter the **UNBIND** command after each update operation to flush data that has been cached from the previous one. You then enter the **BIND** command to reconnect to the **UPD_DRV** service before you perform the next update.

Syntax for the **UNBIND** command is as follows:

```
UNBIND [VDK1:]
```

For example:

```
InfoServer> UNBIND  
%ESS-I-VDDELETE, Virtual device VDK1: deleted.
```

4.13.4 Restrictions

The following restrictions apply for network updates:

- Services intended for remote InfoServer systems must be created in the **ODS_2** service class. When automounted, InfoServer and **VXT** software compact discs appear as **ODS-2** services with the disc's volume label as the service name. For a Function Access compact disc, you must create a service in the **ODS_2** service class.
- Only one **VDK** device can be in use at any time.
- The **VDK** device is a read-only device.

Advanced Operations

4.13 Performing Network Installations and Updates

- If a service becomes unavailable, the InfoServer system does not attempt to reconnect. You must enter an UNBIND command to terminate the connection and then enter a BIND command to reconnect when the service again becomes available.

Troubleshooting

This chapter describes some common problems that might occur when using the InfoServer system. Each section describes possible causes of the problem and lists the corrective steps to take. You might also want to reference the host client's documentation set for information on accessing the InfoServer system.

For more information on troubleshooting the installation of an InfoServer system, refer to the installation and owner's guide for your system.

5.1 Client System Cannot Connect to InfoServer Device

If a client system cannot connect to an InfoServer virtual device, the InfoServer or client system might be configured incorrectly. In that case, an operating system error appears when you use the proper client commands to connect to the device. This section describes some of the possible problems and the corrective steps to take if you observe this symptom.

Possible Problem:

The device does not appear after boot or does not function.

Corrective Steps:

- 1 Enter console mode as described in the installation and owner's manual for your system and enter the following command at the console prompt (>>>):

```
>>> SHOW DEVICE
```
- 2 Verify that there are no SCSI id conflicts. Note the revision level of the device in the display's REV column and verify that that level is at least the minimum listed in the supported hardware section of the current Software Product Description (SPD) document.

Troubleshooting

5.1 Client System Cannot Connect to InfoServer Device

Possible Problem:

The compact disc to which you are trying to connect has been removed from the InfoServer drive.

Corrective Steps:

- ① Determine whether the compact disc has been removed from the InfoServer drive. Log in to either the local or remote LAT terminal server management console, and then enter the SHOW DEVICE command. The Volume Label column lists volume labels for all available compact discs. If the volume label of the compact disc to which you are trying to connect is not listed, the disc has probably been removed from the InfoServer drive.
- ② If the compact disc has been removed, reinsert it into a free InfoServer drive. Then enter the SHOW DEVICE command again and check to see if the volume label of the compact disc is listed.
- ③ When the volume label appears, you should be able to connect to the compact disc from your client system.

Possible Problem:

The InfoServer system, client system, or both are physically disconnected from the local area network (LAN); or, they are attached to different networks.

Corrective Steps:

- ① Determine whether the client and server are on the same LAN. From the client system, enter the command to invoke the MOP LOOP function. For example, on an MS-DOS system with the DECnet software installed:

```
A:\> NCP LOOP CIRCUIT PHYSICAL-ADDRESS 08-00-2B-15-00-9F
LOOP CIRCUIT test started at 15-Oct-1994 11:49:17
Sending loop message 1, 46.
Message echoed by remote circuit loopback 1, 46 bytes.

LOOP CIRCUIT test finished successfully at 15-Oct-1994 11:50:00
A:\>
```

- ② If the MOP LOOP function fails, the client and InfoServer systems are unable to communicate. One or both systems are probably not attached correctly to the same LAN.
- ③ Some client systems can also provide the ability to list servers on the LAN. For example, on an OpenVMS system you can enter the following command:

5.1 Client System Cannot Connect to InfoServer Device

```

$ MCR ESS$LASTCP
%LASTCP-I-VERSION, LASTDRIVER X1.5 is running
LASTCP> SHOW SERVERS
Node           Node           Physical      Active      Start
Name           Id             Address       Links       Time
-----
LAZARUS        08002B157FA6-97A0 AA-00-04-00-A0-0C      0          -
    
```

If the InfoServer system to which you are trying to connect is not listed, the client system and InfoServer system are probably not connected to the same LAN.

- ④ If this is the problem, connect the client and InfoServer system to the same LAN. Inspect the Ethernet connections for both systems to make sure the systems are properly connected.

Possible Problem:

There is a filtering device between your InfoServer system and client system that does not allow the LASTport protocol or multicast address through.

Corrective Steps:

- ① The steps to correct this problem depend on the filtering device that is between the client and the InfoServer system. For example, the filtering device might be an Ethernet bridge.
- ② Enter the appropriate management commands to the filtering device to determine whether the LASTport protocol type is being filtered. The protocol type 80-41 must be allowed across the device for clients and InfoServer systems to communicate.
- ③ Enter the appropriate management commands to the filtering device to determine whether the LASTport multicast address is being filtered. The multicast address must be allowed across the filtering device for clients and InfoServer systems to communicate. The address is 09-00-2B-04-*nn-nn*, where *nn-nn* is the hexadecimal value of the LASTport group that has been set for the server).
- ④ If either the protocol type or multicast address are being filtered, enter the appropriate management commands to the filtering device to allow the LASTport protocol type and multicast address to pass unfiltered. This action should allow client systems to connect to the InfoServer system.

Possible Problem:

The InfoServer system has run out of local memory resources to complete new connections to devices.

Troubleshooting

5.1 Client System Cannot Connect to InfoServer Device

Corrective Steps:

- 1 Determine whether the InfoServer system has run out of memory. Log in to either the local or remote LAT terminal server management console, and then enter the `SHOW SERVER` command. If the % of Pool Free value is below 5 percent, the server might not have enough memory to establish new connections.
- 2 If the server does not have enough memory, the corrective action depends on how the InfoServer system is using memory. If the InfoServer system is offering many unused services to the LAN, you might have to delete some services.
- 3 If the server is performing many concurrent downline loads, it might not be able to accept new connections. You can disable the maintenance operation protocol (MOP) downline load function with the command `SET SERVER MOP DISABLED`.
- 4 The LAT Responder function might be enabled in a large network. You can disable this function.

Possible Problem:

The requested service name for the virtual device has not been served on the InfoServer system.

Corrective Steps:

- 1 Enter the `SHOW SERVER` command to verify that the server state is on. If the state is not on, enter the command `SET SERVER STATE ON` followed by the `SAVE` command.
- 2 Determine whether the InfoServer system is serving the requested service name. Connect to either the local or remote management console, and then enter the `SHOW SERVICE *` command. If the service name being requested is not listed, the InfoServer system is not offering the requested service.
- 3 If the InfoServer system is not offering the requested service, enter the InfoServer `CREATE SERVICE` command to make the device or partition to which you want to connect available under the proper service name. See the description of the `SET SERVER LASTPORT GROUP` command in Chapter 3.
- 4 You might want to save the created service with the `SAVE` command, so the service is always available whenever the InfoServer system reboots.

Possible Problem:

The InfoServer system and client system belong to different LASTport groups.

5.1 Client System Cannot Connect to InfoServer Device

Corrective Steps:

- ① Determine whether the InfoServer system and client system belong to different LASTport groups. Connect to either the local or remote management console, and then enter the SHOW SERVER command. Check the Current LASTport Group field for the group to which the InfoServer system belongs.
- ② Enter the appropriate command on the client system to determine the group to which the client system belongs. For example, on OpenVMS systems:

```

$ MCR ESS$LASTCP
LASTCP> SHOW STATUS
Status of LASTDRIVER X1.5 on node DOUG at 15-Oct-1994 12:16:41
Protocol version 3.1, Uptime: 5 04:09:48.03, Checksum Off,
Slow mode Off

25306 Bytes pool
  8 Ethernet buffers
  0 I/O request packets
  0 Association control blocks
  0 Local session control blocks
  0 LSC In-Use blocks
  0 Transaction control blocks
  2 Circuit status blocks
 44 Node data blocks
  5 Transmit quota
 80 Maximum circuits
  0 LAN group code
  0 Server circuit timeout
    
```

In this example, the LAN group code field lists the group of the client system as 0.

- ③ Enter the appropriate InfoServer or client system command to put both systems into the same LASTport Group. See the SET SERVER LASTPORT GROUP command in Chapter 3.

Possible Problem:

The requested service name is protected by a password on the InfoServer system, and the client system has not supplied the correct password.

Corrective Steps:

- ① Determine whether the InfoServer service has a password. Connect to either the local or remote management console, and then enter the SHOW SERVICE *service_name* command, where *service_name* is the name of the service to which you are trying to connect. Check the Password field to see if password protection is enabled or disabled.

Troubleshooting

5.1 Client System Cannot Connect to InfoServer Device

- ② If the service has password protection, then either disable the password by using the `SET SERVER` command (Chapter 3) or specify the correct password on the client system. Try to make the connection again.

Possible Problem:

There is a read/write conflict in accessing the requested virtual disk. If there is a write-access session to a virtual disk, the InfoServer system does not allow new read sessions and read/write sessions.

Corrective Steps:

- ① Determine whether there is read/write conflict accessing the virtual disk. Connect to either the local or remote management console, and then enter the `SHOW DEVICE DKn:` command, where `DKn:` is the device to which you are trying to connect. This display lists all services offered for that device.
- ② For each service name being offered for the device, enter the `SHOW SERVICE service_name FULL` command. This display lists the number of readers and writers connected to each system. See Section 2.10 for the different read/write policies used by the InfoServer system.
- ③ If there is a read/write conflict to the service, you can do one of the following:
 - Wait until the conflicting connection is disconnected by the other client system.
 - Delete write access to the conflicting service from the InfoServer management console.
 - Delete the conflicting service from the InfoServer system.

Then try to connect to the InfoServer service again.

Possible Problem:

The service name for the virtual device that you are trying to access is in the wrong or different namespace.

Corrective Steps:

- ① Determine the service class under which the service you are requesting is being offered. Connect to either the local or remote management console, and then enter the `SHOW SERVICE service_name` command. The variable `service_name` is the name of the service to which you are trying to connect. The display lists the service class in brackets (`[]`) after the service name.

5.1 Client System Cannot Connect to InfoServer Device

- ② If the service is not offered under the service class for the client system from which you are trying to connect, create the same service name under the appropriate namespace. See the SET SERVER LASTPORT GROUP command in Chapter 3.

Possible Problem:

The service name being requested by the client is offered on more than one InfoServer system. The client is selecting a service name different from the one intended, and the other InfoServer system is not set up correctly to allow client access.

Corrective Steps:

- ① Determine whether the service is offered by more than one InfoServer system. Connect to either the local or remote management console, and then enter the MONITOR SHOW ETHERNET command. Watch the Messages transmitted field under the LASTport counters section, while trying to connect from the client system again. If this counter does not increment during the client access attempt, another InfoServer system might be replying to the request.
- ② If another InfoServer system offers the same service name, use the InfoServer CREATE SERVICE command to create a unique service name for the virtual disk or partition to which you are trying to connect. Then try to connect from the client system again, using the new service name.

Possible Problem:

Disk functions (InfoServer VXT only) or tape functions are not enabled.

Corrective Steps:

- ① Insert the appropriate Function compact disc in an available drive.
- ② Enter the InfoServer command UPDATE FUNCTIONS.

Possible Problem:

The InfoServer system has encountered an internal software logic or hardware error, preventing access to its devices.

Corrective Steps:

- ① If none of the other corrective actions solve this problem, there might be a software logic or SCSI hardware problem.

Troubleshooting

5.1 Client System Cannot Connect to InfoServer Device

- 2 If you have access to the InfoServer hardware unit, examine the eight diagnostic light-emitting diodes (LEDs) on the back of the InfoServer 100 or 150 unit. If the software is running properly, these LEDs should turn on in a rotating pattern from right to left. If the LEDs do not display the rotating pattern, the system is hung. (On the InfoServer 1000 unit, examine the System OK LED on the front of the unit. This LED flashes if the system is running properly.)

To clear the condition, turn the InfoServer system off and on, and then reboot the software.

- 3 If you cannot recover from the problem, reboot the InfoServer system. Then try to make the connection again.
- 4 If you still cannot access the device, enter console mode, as described in the installation and owner's guide for your system and enter the following command at the console prompt (>>>):

```
>>> UNJAM
```
- 5 Please submit a Software Performance Report (SPR), describing in as much detail as possible the problem you experienced, the corrective actions you tried, and the results. Also provide as much information about the client systems as possible.

5.2 Access to InfoServer Devices Seems Slow

Under normal operating conditions, access times for a virtual device on the InfoServer system should be comparable to access times for a locally attached device. In many cases, access to a compact disc on the InfoServer system can appear substantially faster than access to a locally attached compact disc, because of the server's caching policies. If access to virtual devices on the InfoServer system appears unusually slow, a problem might exist in your LAN.

Possible Problem:

The InfoServer system is experiencing "system buffer unavailable" errors. If the LAN load imposed on the system is too great, the client systems and InfoServer system intentionally decrease their LAN message rates to try to resolve the LAN's network-load problem.

Corrective Steps:

- 1 Determine whether the InfoServer system is experiencing "system buffer unavailable" errors. Connect to either the local or remote management console, and then enter the SHOW ETHERNET command.

Check the System Buffer Unavailable counter for a nonzero value. If this counter is not 0 or is incrementing, the LAN load might be too high for the InfoServer system.

- ② If the System Buffer Unavailable counter is incrementing, and you are not performing downline loading from the InfoServer system, you might want to enter the `SET SERVER MOP DISABLED` command. If MOP is enabled, a multicast address is enabled that causes the system to receive messages from the DECnet network that are not intended for the InfoServer system. This event is shown by the Unrecognized Destination field of the `SHOW ETHERNET` display.

Disabling MOP disables this multicast filter on the InfoServer system and reduces the number of unintended messages received by the system. This action might correct the "system buffer unavailable" problem and speed up access to InfoServer devices.

Possible Problem:

The InfoServer system has just rebooted or has had the physical media removed and reinserted. In these cases, the client system might take several seconds to discover the broken connection and reestablish the connection to the InfoServer system.

Corrective Steps:

- ① Determine whether the Server has recently rebooted. Enter the `SHOW SERVER` command, and inspect the Uptime field. The uptime indicates how much time has elapsed since the last reboot.
- ② If the server has recently rebooted or the media has been removed and reinserted, you do not have to perform any corrective action. After the client reconnects to the InfoServer system, the access-delay problem should disappear.

5.3 Cannot Enter InfoServer Commands from a Local Console

The InfoServer management interface is always available from a local terminal connected to a running InfoServer system. This section describes some possible problems and corrective steps if you are unable to enter InfoServer commands from a locally attached terminal.

Troubleshooting

5.3 Cannot Enter InfoServer Commands from a Local Console

Possible Problem:

The local terminal is not connected to the communication serial port on the InfoServer 1000 system or is connected to the wrong serial port on the InfoServer 100 or 150 system.

Corrective Steps:

- ① Make sure that the terminal is connected to the serial port on the InfoServer 1000 unit or to serial port MMJ 1 on the back of the InfoServer 100 or 150 unit.
- ② If the terminal is not connected or is connected to the wrong serial port, connect the terminal correctly.

Possible Problem:

The local terminal is not set up correctly to communicate with the InfoServer system.

Corrective Steps:

- ① Check the attached terminal, and make sure that it is set for:
 - 9600 baud
 - 8 bits, no parity
 - XON/XOFF flow control
- ② If the terminal settings are incorrect, fix them. Then try entering your InfoServer commands again.

Possible Problem:

The InfoServer system had an internal software logic error, preventing access from the terminal console line.

Corrective Steps:

- ① If none of the other corrective actions solve this problem, you might have a software logic problem.
- ② If you have access to the InfoServer hardware unit, examine the eight diagnostic LEDs on the back of the InfoServer 100 or 150 unit. If the software is running properly, these LEDs should turn on in a rotating pattern from right to left. If the LEDs do not display the rotating pattern, the system is hung. (On the InfoServer 1000 unit, examine the System OK LED on the front of the unit. This LED flashes if the system is running properly.)

Turn the InfoServer system off and on to clear the condition, and then reboot the software.

5.3 Cannot Enter InfoServer Commands from a Local Console

- ③ If you cannot recover from the problem, reboot the InfoServer system. Then try entering your InfoServer commands again.
- ④ Please submit a Software Performance Report (SPR), describing in as much detail as possible the problem you experienced, the corrective actions you attempted, and the results. Also provide known information about the attached terminal and its setup.

5.4 Cannot Enter InfoServer Commands from a Remote Console

The InfoServer system uses the LAT protocol to allow remote terminal access to the InfoServer command set. This remote access is always available when the InfoServer system is running. This section describes the possible problems and corrective steps to take if you are unable to enter InfoServer commands from a remote LAT terminal server terminal.

Possible Problem:

The InfoServer system, terminal server, or both are physically disconnected from the LAN; or, they are attached to different networks.

Corrective Steps:

- ① Determine whether the InfoServer system and terminal server are on the same LAN. From the terminal server, enter the command to invoke the MOP LOOP function. For example, on a DECserver 200:

```
Local> TEST LOOP 08-00-2B-15-00-9F
```
- ② If the MOP LOOP function fails, the terminal server and InfoServer system cannot communicate. One or both systems are probably not attached to the same LAN correctly.
- ③ If this is the problem, connect the terminal server and the InfoServer system to the same LAN. Inspect the Ethernet connections for both systems.

Possible Problem:

There is a filtering device between your InfoServer system and the terminal server that does not allow the LAT protocol or multicast address through.

Troubleshooting

5.4 Cannot Enter InfoServer Commands from a Remote Console

Corrective Steps:

- ① The steps to correct this problem depend on the filtering device between the terminal server and the InfoServer system. For example, the filtering device might be an Ethernet bridge.
- ② Enter the appropriate management commands to the filtering device to determine whether the LAT protocol type is being filtered. The protocol type 60-04 must be allowed across the device for terminal servers and InfoServer systems to communicate.
- ③ Enter the appropriate management commands to the filtering device to determine whether the LAT terminal server multicast address is being filtered. The multicast address 09-00-2B-00-00-0F must be allowed across the filtering device for the clients and InfoServer systems to communicate.
- ④ If either the protocol type or multicast address are being filtered, enter the appropriate management commands to the filtering device to allow the LAT protocol type and multicast address to pass unfiltered. This should allow the terminal server to connect to the InfoServer system.

Possible Problem:

The password for the InfoServer system to which you are trying to connect has been changed.

Corrective Steps:

- ① If the InfoServer system has password protection enabled, the terminal server prompts you for a password to connect to the system. If the system does not accept the password you enter, the InfoServer password might have been changed.
- ② If you are unable to determine the new InfoServer password, you can reset the InfoServer password to a known password by following the steps in Section 5.9.

Possible Problem:

The InfoServer system has run out of local memory resources to complete new connections to the management interface.

5.4 Cannot Enter InfoServer Commands from a Remote Console

Corrective Steps:

- ① Determine whether the system has run out of memory. Connect to the local console and enter the `SHOW SERVER` command. If the percentage displayed in the `% of Pool Free` field falls below 5 percent, the server might not have enough memory to establish new `LAT` terminal server connections.
- ② If the server does not have enough memory, the corrective action depends on how the InfoServer system is using memory.
 - If the system is offering many unused services to the LAN, then you might have to delete some services.
 - If the server is performing many concurrent downline loads, it might not be able to accept new connections. You can disable the `MOP` downline load function by using the `SET SERVER MOP DISABLED` command.
 - If there are more than 100 connections to virtual devices, the capacity of the InfoServer system might be exceeded. The `Current Sessions` field of the `SHOW SERVER` command lists the number of connections.

If this is the problem, you must distribute your LAN connections among other available InfoServer systems on the LAN. One way to do this is to put different InfoServer systems and clients into different `LASTport` groups. See the `SET SERVER LASTPORT GROUP` command (Chapter 3) and the appropriate client system documentation for the client syntax for changing `LASTport` groups.

Possible Problem:

The InfoServer system and terminal server do not share a common group code.

Corrective Steps:

- ① Determine whether the InfoServer system and terminal server share common group codes. Connect to either the local or remote management console, and then enter the `SHOW LAT COUNTERS` command. The `Enabled Group Codes` field lists the `LAT` group codes offered by the InfoServer system.
- ② Enter the appropriate command on the terminal server to determine the group codes to which your console has access. For example, on a `DECserver 200`:

Troubleshooting

5.4 Cannot Enter InfoServer Commands from a Remote Console

```
Local> SHOW PORT

Port 5:                               Server: LAT_08002B13EDAF
Character Size:                        8           Input Speed:         4800
Flow Control:                         XON        Output Speed:        4800
Parity:                               None       Modem Control:      Disabled

Access:                               Local      Local Switch:       None
Backwards Switch:                     None      Name:               PORT_5
Break:                                Local     Session Limit:      4
Forwards Switch:                      None     Type:               Soft

Preferred Service: None

Authorized Groups:  0
(Current) Groups:  0

Enabled Characteristics:
Autobaud, Autoprompt, Broadcast, Input Flow Control,
Loss Notification, Message Codes, Output Flow Control,
Verification
```

In this example, the Current Groups field of the display lists the group codes to which the terminal server port can connect.

- 3 Enter the appropriate InfoServer or terminal server commands to enable a common group code for the terminal server port and the InfoServer service. See the SET SERVER LASTPORT GROUP command (Chapter 3).

Possible Problem:

The terminal server being used does not offer access to password-protected LAT terminal server services.

Corrective Steps:

- 1 If the terminal server issues an Invalid Password error message without first prompting you for a password, the terminal server might not support connections to password-protected services.
- 2 Check your terminal server documentation to determine whether connections to password-protected services are allowed.
- 3 If connections to password-protected services are not supported, you cannot use that type of terminal server to connect to the remote console. The service to the InfoServer remote management console is always password protected. Try using another type of terminal server to make the connection.

5.4 Cannot Enter InfoServer Commands from a Remote Console

Possible Problem:

There is more than one InfoServer system with the same server name on the extended LAN. You are connecting to the incorrect InfoServer system, which does not accept your password.

Corrective Steps:

- ① Determine whether there is more than one InfoServer system with the same server name on the extended LAN. Most terminal servers keep a count of duplicate names detected on the LAN. For example, you can enter the following command on a DECserver 200 to check an InfoServer system named LIBRARY_IS:

```
Local> SHOW NODE LIBRARY_IS COUNTERS
```

```
Node: LIBRARY_IS
```

Seconds Since Zeroed:	451828	Multiple Node Addresses:	253
Messages Received:	316	Duplicates Received:	0
Messages Transmitted:	222	Messages Re-transmitted:	0
Slots Received:	177	Illegal Messages Received:	0
Slots Transmitted:	159	Illegal Slots Received:	0
Bytes Received:	7315	Solicitations Accepted:	0
Bytes Transmitted:	208	Solicitations Rejected:	0

If the Multiple Node Addresses field is not 0, there is more than one InfoServer system with the name LIBRARY_IS.

- ② If there is more than one system with the same name, connect a local terminal to one of the InfoServer systems and change its name to a unique name. See the SET SERVER NAME command (Chapter 3).

Possible Problem:

The InfoServer system had an internal software logic error, preventing access to its remote management interface.

Corrective Steps:

- ① If none of the other corrective actions solve this problem, you might have a software logic problem.
- ② If you have access to the InfoServer hardware unit, examine the eight diagnostic LEDs on the back of the InfoServer 100 or 150 unit. If the software is running properly, these LEDs should turn on in a rotating pattern from right to left. If the LEDs do not display the rotating pattern, the system is hung. (On the InfoServer 1000 unit, examine the System OK LED on the front of the unit. This LED flashes if the system is running properly.)

Troubleshooting

5.4 Cannot Enter InfoServer Commands from a Remote Console

To clear the condition, turn the InfoServer system off and on. Then reboot the software.

- ③ If you cannot recover from the problem, reboot the InfoServer system. Then try entering your InfoServer commands again.
- ④ Please submit a Software Performance Report (SPR), describing in as much detail as possible the problem you experienced, the corrective actions you attempted, and the results. Also provide any known information about the remote terminal server and its setup.

5.5 InfoServer Software Does Not Boot

Normally the InfoServer system boots from its internal read/write device. Booting from the internal device rather than from a compact disc allows you to use any compact discs in any InfoServer drive.

If the internal device becomes corrupted or the default boot configuration is altered, the InfoServer system might not boot correctly. This section describes how to recover when the InfoServer software does not boot.

Possible Problem:

The boot flags saved for the InfoServer system have been altered.

Corrective Steps:

- ① Enter console mode, as described in the installation and owner's guide for your system.
- ② At the console prompt (>>>), enter the following command:

```
>>> SHOW BOOT
```

On InfoServer 100 and 150 systems, the BOOT parameter must be set to DKA200,DKA100. If the SHOW BOOT command displays a different setting, enter the following command:

```
>>> SET BOOT DKA200,DKA100
```

On InfoServer 1000 systems, the BOOT parameter must be set to FLASH. If the SHOW BOOT command displays a different setting, enter the following command:

```
>>> SET BOOT FLASH
```

- ③ Enter the following command:

```
>>> SHOW BFLG
```

To boot with normal defaults, the BFLG parameter must be set to the hexadecimal value D0000000. If the SHOW BFLG command displays a different setting, enter the following command:

```
>>> SET BFLG D0000000
```

- ④ Enter the following command:

```
>>> SHOW HALT
```

The HALT parameter must be set to 2. If the SHOW HALT command displays a different setting, enter the following command:

```
>>> SET HALT 2
```

- ⑤ When all booting parameters are set correctly, try to boot the InfoServer software:

```
>>> B
```

In some circumstances, you might want to set boot flags to values other than the normal defaults—for example, to specify a secondary bootstrap file. Table 5–1 lists InfoServer boot flags and describes their functions. Note that each byte maps to one hexadecimal digit.

To prompt for the name of a secondary bootstrap file (bit 8 set), you would enter the following command:

```
>>> B/D0000080
```

To restore default settings (bit 1 set), you would enter the following command:

```
>>> B/D0000001
```

Table 5–1 InfoServer Boot Flag Bits

Bit	Function When Set
0	Boot with default settings.
1	Enable pool poisoning.
2	Take initial breakpoint.
<7:3>	Not used with InfoServer systems.
8	Prompt for the name of a secondary bootstrap file.
<20:9>	Not used with InfoServer systems.
21	Disable verification of InfoServer-formatted disks on boot.
<27:22>	Not used with InfoServer systems.
<31:28>	Specifies the top level directory number for system disks with multiple systems (must be hexadecimal D for InfoServer systems).

Troubleshooting

5.5 InfoServer Software Does Not Boot

Possible Problem:

The system software is corrupted on the internal read/write disk (InfoServer 100 and 150 only). This problem could be caused by clients on the LAN accessing the device accidentally, or by a device failure.

Corrective Steps:

- 1 Boot the software from the InfoServer compact disc instead of from the internal read/write device. Insert the compact disc supplied with the InfoServer unit into a compact disc drive. Enter the REBOOT command or turn the unit off and on to reboot the unit.

- 2 After booting from the compact disc, enter the following InfoServer command:

```
InfoServer> SHOW PARTITION DK1:
```

- 3 If the SHOW PARTITION command succeeds, but the special partition named BOOT_PARTITION does not appear, only the system software has been lost. To recover, enter the following InfoServer command:

```
InfoServer> UPDATE SYSTEM DK2: DK1:
```

- 4 If an error occurs on the SHOW PARTITION command, the format of the internal disk has been lost. In this case, you must initialize the disk before the system software is copied, as in the following example:

```
InfoServer> SET SERVER STATE OFF  
InfoServer> INITIALIZE DK1:  
InfoServer> UPDATE SYSTEM DK2: DK1:  
InfoServer> SET SERVER STATE ON
```

Possible Problem:

An unsupported device is preventing the software from completing device initialization.

Corrective Step

Remove any unsupported devices.

Possible Problem:

A hardware failure occurred on the InfoServer system.

Corrective Steps:

- 1 If none of the other corrective steps in this section solve the problem, then your InfoServer system might have a hardware failure.
- 2 Call your Digital service representative for assistance in repairing or replacing the InfoServer unit.

5.6 Online Help No Longer Available

If the internal read/write device is partially corrupted, online help might no longer be available. To reinstall online help, follow these steps:

- 1 Connect to either the local or remote management console on the InfoServer system.
- 2 Insert the compact disc supplied with the InfoServer unit into a compact disc drive, for example, DK2. If a disc is already installed in the drive, remove that disc and reinstall it at the end of this procedure.
- 3 If the InfoServer compact disc is in DK2, enter the following command to update the system software on InfoServer 100 or 150 systems:

```
InfoServer> UPDATE SYSTEM DK2: DK1:
```

For InfoServer 1000 systems, enter the following command:

```
InfoServer> UPDATE SYSTEM DK2: FLASH
```
- 4 If you removed another compact disc to insert the InfoServer compact disc, reinstall that disc now.

5.7 InfoServer System Does Not Boot Completely

If the InfoServer system starts to boot but does not display the Password: prompt, the internal read/write device might be corrupted. This section lists the steps you can take to correct this problem.

Possible Problem:

The configuration partition used to store InfoServer parameters, services, and other operational characteristics on the internal InfoServer 100 or 150 read/write disk might be corrupted.

Corrective Steps:

- ① Connect a local terminal to serial port MMJ 1 on the rear of the InfoServer unit. Make sure the terminal is set to 9600 baud, 8 bits, no parity. You must use a local terminal; remote LAT terminal server terminals do not work with this procedure.
- ② Press the halt switch on the rear of the InfoServer unit. The console prompt (>>>) should appear.
- ③ At the prompt, enter the following command:

```
>>> B/D0000001
```

Troubleshooting

5.7 InfoServer System Does Not Boot Completely

This command causes the InfoServer software to boot without reading the configuration database from the read/write disk. Therefore, all system defaults are in effect for this boot.

- ④ At the Enter Password: prompt, enter the default password ESS.
- ⑤ Reenter the characteristics that you want to save for the InfoServer system, then enter the SAVE command. This should correct the corruption of the configuration partition.

Possible Problem:

The InfoServer operational software section of the internal read/write disk on an InfoServer 100 or 150 system disk might be partially corrupted.

Corrective Steps:

- ① Boot the software from the InfoServer compact disc instead of from the read/write disk. Insert the compact disc supplied with the InfoServer unit into the compact disc drive on the right side of the InfoServer unit's front panel. Turn the InfoServer system off and on to reboot the unit.
- ② After booting from the compact disc, enter the following InfoServer command:

```
InfoServer> SHOW PARTITION DK1:
```

- ③ If the SHOW PARTITION command succeeds, but the special partition named BOOT_PARTITION does not appear, only the system software has been lost. To recover, enter the following InfoServer command:

```
InfoServer> UPDATE SYSTEM DK2: DK1:
```

- ④ If an error occurs on the SHOW PARTITION command, the format of the disk has been lost. In this case, you must initialize the disk before the system software is copied, as in the following example:

```
InfoServer> SET SERVER STATE OFF  
InfoServer> INITIALIZE DK1:  
InfoServer> UPDATE SYSTEM DK2: DK1:  
InfoServer> SET SERVER STATE ON
```

Possible Problem:

The InfoServer operational software section of FLASH ROM on an InfoServer 1000 might be partially corrupted.

5.7 InfoServer System Does Not Boot Completely

Corrective Steps:

- 1 You must have a compact disc drive available, either locally attached or accessible on a system that can MOP downline load your unit.

If you have a locally attached drive, insert the InfoServer compact disc into the drive and enter a command in the following format, where *n* is the number of the drive holding the disc:

```
InfoServer> UPDATE SYSTEM DKn: FLASH
```

If the compact drive is located on a remote system, you can MOP downline load the system software as described in Chapter 4.

- 2 If console code is still valid but system software is corrupt, insert the InfoServer kernel compact disc in a drive and enter the commands shown:

```
>>> B/100 DNnnn:
Bootfile: [SYSD.SYSEXE]LOCSUPDATE.EXE
```

Possible Problem:

A hardware failure occurred on the InfoServer system.

Corrective Steps:

- 1 If none of the other corrective steps in this section solve the problem, then your InfoServer system might have a hardware failure.
- 2 Call your Digital service representative for assistance in repairing or replacing the InfoServer unit.

5.8 InfoServer System Does Not Downline Load Clients

The InfoServer system can automatically downline load client systems that request a specific load image by file name or Ethernet address. If the InfoServer manager has created the proper MOP partition on the InfoServer system, downline loading should work. This section describes the possible problems and corrective steps to take if you are unable to downline load a system from an InfoServer system.

Possible Problem:

The MOP downline loading feature is disabled on the InfoServer system.

Troubleshooting

5.8 InfoServer System Does Not Downline Load Clients

Corrective Steps:

- 1 Determine whether MOP downline loading is disabled on the InfoServer system. Connect to either the local or remote management console, and then enter the SHOW MOP command. If downline loading is disabled, asterisks (*) appear at the bottom of the display.
- 2 If MOP downline loading is disabled, enter the SET SERVER MOP ENABLED command to reenable downline loading.

Possible Problem:

The InfoServer system, the system requesting a downline load, or both are physically disconnected from the LAN; or, they are attached to different networks.

Corrective Steps:

- 1 Determine whether the InfoServer system and the client system requesting a downline load are on the same LAN. Most client systems cannot perform a MOP LOOP test before they are downline loaded. You must monitor the InfoServer counters to determine whether the InfoServer system and client system are connected.
- 2 Connect to either the local or remote management console. Then enter the following commands:

```
InfoServer> ZERO MOP  
InfoServer> MONITOR SHOW MOP
```

Try to downline load from the remote system again. If the remote system still fails to load and none of the MOP counters in the SHOW MOP display increment, the InfoServer system and remote system requesting a downline load are probably not connected to the same LAN.

- 3 If this is the problem, connect the requesting system and InfoServer system to the same LAN. Inspect the Ethernet connections for both systems.

Possible Problem:

There is a filtering device between your InfoServer system and client system that does not allow the MOP protocol or multicast address through.

Corrective Steps:

- 1 The steps to correct this problem depend on the filtering device between the client and the InfoServer system. For example, the filtering device might be an Ethernet bridge.

5.8 InfoServer System Does Not Downline Load Clients

- ② Enter the appropriate management commands to the filtering device to determine whether the MOP-loading protocol type is being filtered. The protocol type 60-01 must be allowed across the device for requesting systems and InfoServer system to communicate.
- ③ Enter the appropriate management commands to the filtering device to determine whether the MOP-loading multicast address is being filtered. The multicast address AB-00-00-02-00-00 must be allowed across the filtering device for the requesting system and InfoServer system to communicate.
- ④ If either the protocol type or multicast address are being filtered, enter the appropriate management commands to the filtering device to allow the MOP-loading protocol type and multicast address to pass unfiltered. This should allow the requesting system to downline load from the InfoServer system.

Possible Problem:

The InfoServer system has run out of local memory resources to complete new downline load requests.

Corrective Steps:

- ① Determine whether the InfoServer system has run out of memory. Connect to either the local or remote management console, and then enter the SHOW SERVER command. If the percentage displayed in the % of Pool Free field falls below 5 percent, the server might not have enough memory to handle new downline load requests.
- ② If the server does not have enough memory, the corrective action depends on how the InfoServer system is using memory.
 - If the InfoServer system is offering many unused services to the LAN, then you might have to delete some services.
 - If there are more than 100 connections to virtual devices, the capacity of the InfoServer system might be exceeded. The Current Sessions field of the SHOW SERVER command lists the number of connections.
If this is the problem, you need to distribute your LAN connections among other available InfoServer systems on the LAN. One way to do this is to put different InfoServer systems and clients into different LASTport groups. See the SET SERVER LASTPORT GROUP command (Chapter 3) and the appropriate client system documentation for the client syntax for changing LASTport groups.

Troubleshooting

5.8 InfoServer System Does Not Downline Load Clients

Possible Problem:

The InfoServer system is currently processing the maximum number of downline load requests that it can handle.

Corrective Steps:

- ① Determine whether the maximum number of downline load requests has been exceeded. Connect to either the local or remote management console, and then enter the SHOW MOP command. If the Load failed, server limit counter is not 0, the InfoServer system was handling its limit of downline load requests at some point.
- ② Wait until the InfoServer system completes some of the current downline loads and the Loads in progress count gets smaller. Then try the downline load operation from the requesting system again.

Possible Problem:

The InfoServer system does not contain the downline loadable image requested.

Corrective Steps:

- ① Determine whether the InfoServer system has the requested downline loadable image installed. Connect to either the local or remote management console, and then enter the SHOW MOP command. If the Load error, file not found counter increments each time the requesting system attempts a downline load, the InfoServer system does not have the image requested.
- ② See Section 4.9 for information on installing MOP downline loadable images.
- ③ Use the appropriate commands to install the desired downline loadable image. Then try the downline load operation again.

Possible Problem:

The InfoServer partition that contains the requested downline loadable image is not set up as a MOP partition.

Corrective Steps:

- ① Determine whether the InfoServer partition is a MOP partition. Connect to either the local or remote management console, and then enter the SHOW MOP command. Check if the Load failed, partition type count is a value other than 0. If this counter increments each time the remote system tries to downline load, the partition containing the load image is not set up properly.

5.8 InfoServer System Does Not Downline Load Clients

- ② Enter the `SHOW PARTITION DKn:image_name` command. *DK*n**: is the device holding the image partition, and *image_name* is the name of the requested image. If the partition is listed without a MOP flag after the size field, the image is not set up to be downline loaded.
- ③ Use the `SET PARTITION` command to enable the partition to be downline loaded.

Possible Problem:

The downline loadable image in the requested MOP partition was not copied to the server correctly, so the image has an invalid or unrecognized format. Or the image is too large to downline load in the requested manner.

Corrective Steps:

- ① Determine whether the InfoServer system has a bad load image that it cannot load. Connect to either the local or remote management console, and then enter the `SHOW MOP` command. Check the following error counters for values other than 0:
 - Load failed, not contiguous
 - Load failed, read error
 - Load failed, protocol error
 - Load failed, file too big
 - Load failed, bad file type

If any of these counters increment each time the remote system tries to downline load, the load image is not installed correctly on the InfoServer system.

- ② See Section 4.9 for information on installing MOP downline loadable images.
- ③ Use the appropriate command or commands to install the desired downline loadable image, then try the downline load operation again.

Possible Problem:

The InfoServer system has an internal software logic error that is preventing access to its devices or preventing the server from responding to the load request.

5.8 InfoServer System Does Not Downline Load Clients

Corrective Steps:

- ❶ If none of the other possible problems and solutions solve your problem, you might have a software logic problem.
- ❷ If you have access to the InfoServer hardware unit, examine the eight diagnostic LEDs on the back of the InfoServer 100 or 150 unit. If the software is running properly, these LEDs should turn on in a rotating pattern from right to left. If the LEDs do not display the rotating pattern, the system is hung. (On the InfoServer 1000 unit, examine the System OK LED on the front of the unit. This LED flashes if the system is running properly.)

To clear the condition, turn the InfoServer system off and on. Then reboot the software.
- ❸ If you cannot recover from the problem, reboot the InfoServer system. Then try the operation again.
- ❹ Please submit a Software Performance Report (SPR), describing in as much detail as possible the problem you experienced, the corrective actions you attempted, and the results. Also provide any known information about the requesting system and its setup.

5.9 InfoServer Password Forgotten

The InfoServer system has the default password ESS, which you can change by entering the SET SERVER PASSWORD command. You must enter the correct password before you can start an InfoServer management session, either locally or remotely. If you forget your InfoServer password, you can reset the InfoServer system to its default configuration and password. Follow these steps:

- 1 Connect a local terminal to the MMJ 1 serial port on the rear of the InfoServer 100 or 150 system or to the serial port on the InfoServer 1000 system. Make sure the terminal is set to 9600 baud, 8 bits, no parity. You must use a local terminal; remote LAT terminal server terminals do not work with this procedure.
- 2 Enter console mode as described in the installation and owner's guide for your InfoServer system.
- 3 At the console prompt (>>>), enter the following command:

>>> B/D0000001

This command causes the InfoServer software to boot without reading the configuration database from the internal read/write device. Therefore, all system defaults are in effect for this boot.

- 4 At the Enter Password: prompt, enter the default password ESS. You now have access to InfoServer commands.
- 5 After you log in, you can restore all of the previous system configuration by using the RESTORE command:

```
InfoServer> RESTORE
%ESS-I-RESTORE, Restoring Configuration from DK1:
InfoServer>
```

- 6 Change the server password to a known value:

```
InfoServer> SET SERVER PASSWORD
_Password: NEW_PASSWORD (not echoed)
_Verification: NEW_PASSWORD (not echoed)
InfoServer>
```

- 7 Save the current settings, including the new password, by entering the SAVE command:

```
InfoServer> SAVE
%ESS-I-MAVED, Save completed successfully to DK1:
InfoServer>
```

The system is now restored to its previously saved configuration. Your new password is also saved.

Server Command Syntax Summary

This appendix summarizes the command syntax for InfoServer management commands, which are described in detail in Chapter 3.

BACKUP *src_device[:]* *dest_device[:]*

BIND *ODS-2-service-name* [PASSWORD *optional-password*]

CLEAR

COPY *src_device[:partition]* *dest_device[:partition]*

CRASH [YES]

CREATE { PARTITION *DKn:partition* { BLOCKS
BYTES
MEGABYTES } *n* [MOP] { DISABLED
ENABLED } [ERASE]
SERVICE *service-name* [FOR *device[:partition]*]
[CLASS *class-name*
DYNAMIC_RATING
[NO]PASSWORD *string*
[NO]READERS *number*
[NO]WRITERS *number*
STATIC_RATING *rating*] }

Server Command Syntax Summary

DELETE { PARTITION *device:partition* [ERASE]
SERVICE *service-name* [FOR *device[:partition]*] [CLASS *class-name*] }

DISCONNECT { LAST
LAT } *session-number*

ERASE { *device[:partition]*
NVRAM { FUNCTIONS
SERVICES } } }

EXIT [LOGOUT]

HELP [*topic*] [*subtopic...*]

INITIALIZE *device[:]*

LOOP [*server-command*]

MONITOR [*server-command*]

PURGE VXT *src_device[:]* [*dest_device[:]*]

RECORD *src_device[:partition]* *dest_device[:]* [TIME *minutes*
SPEED {1 | 2}
ISO | HSFS
SIZE *bytes*
TEST]

RESTORE [*device[:]*]

RETRIEVE *src_device[:]* *dest_device[:]*

REWIND *[device:]*

SAVE *[device:]*

```

DEVICE { ALL { device-list } }
        { AUTOMOUNT { ENABLED } }
PARTITION device:partition MOP {DISABLED | ENABLED}
[SERVER] AUTOMOUNT {DISABLED | ENABLED}
[SERVER] CACHE BUCKETSIZE {8 | 16 | 32}
[SERVER] CACHE SIZE size
[SERVER] CRASHDUMP {DISABLED | ENABLED} [device[:]]
[SERVER] EXTENSION [LIMIT] value
[SERVER] GROUP [CODES] { ALL { code-list } }
        { DISABLED }
[SERVER] IDENTIFICATION "string"
[SERVER] LASTPORT [GROUP] value
[SERVER] LAT_RESPONDER {DISABLED | ENABLED}
[SERVER] MOP {DISABLED | ENABLED}
[SERVER] MULTICAST [TIMER] value
[SERVER] NAME server-name
[SERVER] { PASSWORD { NONPRIVILEGED } }
        { PASSWORD string }
[SERVER] PROMPT "string"
[SERVER] REMOTE [DEVICE] device-list {DISABLED | ENABLED}
[SERVER] STATE {OFF | ON | SHUT}
[SERVER] WRITE [ACCESS] {BLOCKING | PRE-EMPTIVE}
SERVICE service-name [FOR] device:partition] [CLASS class-name]
[NO]READAHEAD
[NO]READBEHIND
[NO]READERS number
[NO]WRITERS number
[STATIC_RATING] rating
DYNAMIC_RATING
[NO]PASSWORD string
[NO]READAHEAD
[NO]READBEHIND
[NO]READERS number
[NO]WRITERS number
[STATIC_RATING] rating
    
```

SET

Server Command Syntax Summary

SHOW {
 DEVICE [DK[n[:]]] { BRIEF }
 TP[n[:]]] { FULL }
 ETHERNET [COUNTERS]
 FUNCTIONS
 LAST [SESSIONS] [CLASS *class-name*]
 LAT { COUNTERS }
 SESSIONS }
 MOP [COUNTERS]
 PARTITIONS { *device[:partition]* }
 [BRIEF]
 [FULL] }
 SERVER { CHARACTERISTICS }
 COUNTERS }
 STATISTICS }
 SERVICE [*service-name* [BRIEF] [CLASS *class-name*]
 FULL] }
 TAPE [COUNTERS]

UNBIND [VDK1[:]]

UNLOAD *device[:]*

UPDATE { FUNCTIONS } *src_device[:]* [*dest_device[:]*]
 SYSTEM
 VXT

VERIFY *device[:]* { NOREPAIR }
 REPAIR }

ZERO { ALL
 ETHERNET
 LAT
 MOP
 SERVER
 TAPE } [COUNTERS]

Server Messages

This appendix lists user messages that the InfoServer system displays. The appendix also provides corrective steps for error and warning messages.

The InfoServer system displays three types of messages to the user: error messages, informational messages, and warning messages. You can identify each type of message by using its one-letter prefix. Following the prefix is a reason code and a simple text message explaining the error.

Informational message:	<i>%ESS-I-reason, text</i>
Error message:	<i>%ESS-E-reason, text</i>
Warning message:	<i>%ESS-W-reason, text</i>

Informational messages are positive feedback indicating that the attempted operation succeeded. These messages also tell you about results that might not be obvious from the command.

Error messages indicate that a command failed to execute properly. The message should help you identify and correct the problem. Consult the other chapters in this manual if necessary.

Warning messages indicate that a server restriction prevented a command from executing.

B.1 Informational Messages

%ESS-I-CANTSHARE, Setting reader and writers to 1 for service

Explanation: You attempted to set a tape service to have more than one reader or writer. The InfoServer is informing you that it set the readers and writers to the maximum value allowed (1) for you.

%ESS-I-COPIED, Copy operation completed successfully.

Explanation: A copy operation completed successfully.

%ESS-I-CREATED, Create partition completed successfully.

Explanation: A partition was created successfully. This can be the result of a COPY or CREATE PARTITION command.

%ESS-I-CREATED, Create service completed successfully.

Explanation: One or more services were created successfully.

%ESS-I-CREATEBOOT, Creating boot partition.

Explanation: The system is creating a new boot partition when starting up. If the system finds that the first read/write device in the system is not an InfoServer device, the system initializes the device and creates a boot partition.

%ESS-I-CREATEDBOOT, Boot partition created successfully.

Explanation: The boot partition has been created.

%ESS-I-DELETED, Delete partition completed successfully.

Explanation: A partition was deleted successfully.

%ESS-I-DELETED, Delete service completed successfully.

Explanation: One or more services were deleted successfully.

%ESS-I-INIT, Initialize completed successfully on DKn:

Explanation: A device was initialized successfully.

%ESS-I-INITSERVER, Reading Server Database from DKn:

Explanation: When the server started up, it found a configuration partition on device DKn: and initialized the server from it.

%ESS-I-RESTORED, Restore completed successfully from DKn:

Explanation: A restore operation completed successfully. The message tells you from which device the configuration partition was read.

%ESS-I-SAVED, Save operation completed successfully to DKn:

Explanation: A save operation completed successfully. The message tells you to which device the configuration partition was written.

%ESS-I-SET, Set operation completed successfully.

Explanation: A SET command completed successfully.

%ESS-I-TAPECLASS, Creating service under class TAPE

Explanation: You attempted to create a service for a tape device under one of the disk service classes. The InfoServer is informing you that it changed the class to the correct one (TAPE) for you.

%ESS-I-UPDATE, Update operation completed successfully.

Explanation: An update command completed successfully.

B.2 Error Messages

%ESS-E-BADKEYWORD, Unrecognized keyword - xxx

Explanation: You entered a keyword xxx that is not part of the InfoServer's command syntax. See Chapter 3 for the correct syntax.

%ESS-E-BADFORMAT, Configuration database has been corrupted on DKn:

Explanation: A configuration partition has been corrupted. Delete the partition named CONFIGURATION on the device. Use the COPY command to restore the configuration from another source, or reenter the configuration and enter a SAVE command.

%ESS-E-BADSTRING, Error parsing quoted string

Explanation: You entered a quoted string in the incorrect format. The SET SERVER IDENTIFICATION command takes a quoted string as a parameter. See Chapter 3 for more details.

%ESS-E-BADUPDATEFILE, Update file is corrupt.

Explanation: The update file on the update media is bad. Obtain another copy of the update compact disc.

%ESS-E-BADVALUE, Value invalid or out of range -

Explanation: You entered a value that is outside the valid range of the command parameter.

Server Messages

B.2 Error Messages

%ESS-E-CONSOLEONLY, Command is legal only from the console terminal.

Explanation: The command may not be executed from a LAT session. Retry the command with a terminal attached to the InfoServer 1000 serial port.

%ESS-E-CREATEFAILED, Could not create service or partition, xxx

Explanation: A CREATE command failed. Following this message is an error message giving the exact reason the command failed. For example, one reason might be that the device is full.

%ESS-E-DEVICEFULL, Device is full. Partition was not created.

Explanation: An InfoServer device is full. You can use the DELETE PARTITION command to recycle partitions that are no longer needed.

%ESS-E-DEVNOTSUPPORTED, Specified device is not supported by this platform.

Explanation: The FLASH device is supported only on the InfoServer 1000 system.

%ESS-E-DUPLNAM, Service name already exists.

Explanation: You tried to create a service name that already exists. For this error to occur, the duplicate service name must be for the same device (or device and partition), in the same service class.

%ESS-E-DUPPARNAME, Partition name is already used.

Explanation: You tried to create a partition on a device with the same name as an existing partition. Please select a different name for the new partition.

%ESS-E-FAILEDBOOT, Boot partition failed to be created.

Explanation: A boot partition (BOOT_PARTITION) failed to be created on a device during an UPDATE SYSTEM command. For example, the device could be full.

%ESS-E-FILENOTFOUND, File not found, file_name

Explanation: An update operation failed to locate the distribution files on the compact disc. Check that the correct compact disc is in the correct drive, then retry the operation.

%ESS-E-INITFAILED, Failed to initialize device DKn:

Explanation: The device cannot be initialized due to a hard failure such as a write error. Following this message is another message with more specific information on the reason for the failure.

%ESS-E-INSUFFICIENTCACHE, Insufficient cache for update.

Explanation: The system should have a minimum of 1 MB cache. Use the **SET SERVER CACHE SIZE** command to increase the cache size, reboot the InfoServer, and retry the command.

%ESS-E-INVALIDPARG, Expecting ascii string

Explanation: You did not enter a string for a parameter that requires a string.

%ESS-E-INVALIDPARG, Expecting numerical value

Explanation: You did not enter a number for a parameter that requires a numeric value.

%ESS-E-NOHELPPFILE, Failed to locate InfoServer help text.

Explanation: The system cannot find the InfoServer's help file. To restore the help file, see Section 5.6.

%ESS-E-NOHELPPFOUND, Sorry, no documentation on xxx

Explanation: No online help exists for the requested topic. Refer to this guide for help.

%ESS-E-NOPOOL, Insufficient memory available for operation

Explanation: The server's memory is exhausted. This may be a temporary condition that corrects itself, or the server may be overloaded. Try the operation again. If the failure occurs a second time, you can set the server to the off state, perform the operation, and set the server state back on. This should free up enough resources to complete any operation.

%ESS-E-NOSUCHDEV, Device not found.

Explanation: You tried to perform an operation on a device that is not present in the configuration. Use the **SHOW DEVICE** command to list all devices on the InfoServer.

%ESS-E-NOSUCHSERVICE, Service not found, xxx

Explanation: You tried to set or delete a service *xxx* that does not exist. The service being accessed may be in a different namespace, or you may have misspelled the name.

Server Messages

B.2 Error Messages

%ESS-E-NOTESODS, Device does not have InfoServer disk format.

Explanation: You tried an operation that can only be performed on an InfoServer device. InfoServer devices are devices that have been initialized with the INITIALIZE command.

%ESS-E-NOTOFF, Server must be in the OFF state to perform local disk operations.

Explanation: The server state was on when you entered a COPY, INITIALIZATION, or UPDATE command. These commands require the server state to be off.

%ESS-E-NOTRWDEV, Can not write to device.

Explanation: A write operation was attempted to a compact disc. One example is the INITIALIZE command.

%ESS-E-ODSVERSION, This InfoServer disk was created with newer software. Please use newer version.

Explanation: An older version of the InfoServer software tries to read a disk that was formatted by a newer version of the software. Always use the newest version of the InfoServer software.

%ESS-E-PARNOTFOUND, Partition not found.

Explanation: You tried to reference a partition that does not exist. The SHOW PARTITIONS command lists all the partitions on a device.

%ESS-E-PARPERM, This partition can not be deleted.

Explanation: You tried to delete a partition that is managed by the server. For example, the BOOT_PARTITION is a partition that cannot be deleted.

%ESS-E-PARMTOOLONG, Parameter supplied was too long.

Explanation: You entered a command parameter string that is longer than the allowed length.

%ESS-E- RESTOREFAILED, Could not restore configuration from DKn:

Explanation: You tried to restore a configuration, and the operation failed. Following this message is another message giving the exact reason the command failed. For example, one failure might be that the configuration partition was not found.

%ESS-E-FAILED, Could not save configuration to DKn:

Explanation: You tried to save the server's configuration to a device that is either not an InfoServer device or not a read/write device. Repeat the command to an InfoServer device.

%ESS-E-SCSIREADERROR, Error Reading disk.

Explanation: The server received an error reading data from a device. Try the operation again. If the error continues, call your field service representative.

%ESS-E-SCSIWRITEERROR, Error writing disk.

Explanation: The server received an error writing data to a device. Try the operation again. If the error continues, call your field service representative.

%ESS-E-SIZEMISMATCH, Source and Destination sizes must be equal.

Explanation: You tried to copy a device or partition to a destination device or partition with a different size. The source and destination device must be the same size.

%ESS-E-UNKNOWNCOMMAND, Unrecognized command.

Explanation: You entered a command that is not part of the InfoServer's command set. See Chapter 3 for the correct syntax.

%ESS-E-VERIFYERR, Verification password failed to match new password.

Explanation: You entered a verification password that does not match a new password. Please repeat the operation.

%ESS-E-WRONGPASSWORD, Invalid password. Please try again.

Explanation: You entered a password that does not match the current server's password. Enter the correct password, or see Section 5.9 if you cannot remember the password.

%ESS-E-WRONGSTATE, Server state must be OFF to perform this operation.

Explanation: You tried a COPY or UPDATE command with the server in the on state. The server state must be off for these commands, to preserve data integrity by limiting access to the server. This prevents remote disk operations from interfering with local disk operations.

B.3 Warning Messages

%ESS-W-BADFUNC, Bad function found, continuing with other functions...

Explanation: A bad function was found on a Function compact disc, and was skipped over by the InfoServer.

%ESS-W-CANTSHARE, Tapes cannot be shared by more than 1 user concurrently

Explanation: You attempted to set a tape service to have more than one reader or writer. Tape devices cannot be shared concurrently more than one client at a time.

%ESS-W-ENDOFTAPE, End of tape reached, copied data truncated

Explanation: The data specified in the source of a COPY command would not fit on one tape. The InfoServer truncated the data that would not fit on the tape.

%ESS-W-NOTINF, Device not InfoServer-formatted, omitted from operation

Explanation: You specified a device in a list (for example, in the SET SERVER REMOTE DEVICE command) that does not have InfoServer format (for example, has not been formatted with the InfoServer INITIALIZE command). The InfoServer skips the device listed and continues to operate on the rest of the list.

%ESS-W-NOTPRESENT, Device not present, omitted from operation

Explanation: You specified a device in a list (for example, in the SET SERVER REMOTE DEVICE command) that does not exist on the InfoServer. The InfoServer skips the device listed and continues to operate on the rest of the list.

%ESS-W-NOWRITERS, CD volumes cannot be written. Setting maximum writers to zero.

Explanation: You tried to set write access on a compact disc. Compact discs on the InfoServer are read-only.

%ESS-W-TAPECLASS, Tape devices can be served only under class TAPE

Explanation: You tried to create a service for a tape device under one of the disk service classes. Tape devices can only be served under the TAPE class.

A

Advanced functions

- assigning multiple service names, 4-3
- assigning passwords to protect compact discs, 4-3

backing up data

- locally, 4-6
- remotely, 4-7

backing up read/write data, 4-6

- configuring X terminals, 4-12
- creating and serving partitions, 4-4
- creating MOP partitions for downline loading, 4-10

defragmenting InfoServer disks, 4-8

- replicating InfoServer disks, 4-9
- serving external read/write disks, 4-5
- serving updated compact discs, 4-2

Assigning a name to InfoServer system, 2-8

Automatic service, 1-4

Automount function, 2-3

- disabling for individual devices, 1-4, 3-37
- disabling serverwide, 1-4, 3-39
- enabling for individual devices, 3-37
- enabling serverwide, 3-39

Automounting compact discs, 3-39

Availability

- devices, 1-4
- services, 1-4

B

Backing up data

- locally, 4-6
- remotely, 4-7

Backing up read/write data, 4-6

BACKUP command, 3-4, 3-33

BIND command, 3-6

Booting the system

- setting boot flags, 5-17
- troubleshooting, 5-16
 - partial boot, 5-19
- updating software, 3-102

Buses, 2-10

C

Central database

- nightly updates, 3-59

Class names, 3-14

CLEAR command, 3-7

Client

- accessing server devices, 1-3
- serving devices to, 4-3
- X terminal, 1-3

Commands

BACKUP, 3-4, 3-33

BIND, 3-6

CLEAR, 3-7

COPY, 3-8

CRASH, 3-10

CREATE PARTITION, 3-11

CREATE SERVICE, 3-13

DELETE PARTITION, 3-17

Commands (cont'd)

- DELETE SERVICE, 3-18
- DISCONNECT, 3-20
- ERASE, 3-21
- EXIT, 3-22
- HELP, 3-23
- INITIALIZE, 3-24
- LOOP, 3-25
- MONITOR, 3-26
- PURGE VXT, 3-27
- REBOOT, 3-28
- RECORD, 3-29
 - repeating, 3-25, 3-26
- RESTORE, 3-31
- RETRIEVE, 3-4, 3-33
- REWIND, 3-34
- SAVE, 3-35
- SET DEVICE, 3-37
- SET PARTITION, 3-38
- SET SERVER AUTOMOUNT, 3-39
- SET SERVER CACHE BUCKETSIZE, 3-40
- SET SERVER CACHE SIZE, 3-41
- SET SERVER CRASHDUMP, 3-42
- SET SERVER EXTENSION, 3-44
- SET SERVER GROUP, 3-45
- SET SERVER IDENTIFICATION, 3-47
- SET SERVER LASTPORT GROUP, 3-48
- SET SERVER LAT_RESPONDER, 3-49
- SET SERVER MOP, 3-50
- SET SERVER MULTICAST, 3-52
- SET SERVER NAME, 3-53
- SET SERVER PASSWORD, 3-54
- SET SERVER PROMPT, 3-55
- SET SERVER REMOTE, 3-56
- SET SERVER STATE, 3-58
- SET SERVER WRITE ACCESS, 3-59
- SET SERVICE, 3-60
- SHOW DEVICE, 3-63
- SHOW ETHERNET, 3-66
- SHOW FUNCTIONS, 3-71
- SHOW LAST, 3-72
- SHOW LAT, 3-73
- SHOW MOP, 3-78
- SHOW PARTITIONS, 3-82

Commands (cont'd)

- SHOW SERVER, 3-85
- SHOW SERVICE, 3-91
- SHOW TAPE, 3-96
 - special keys, 3-2
 - summary, 1-6
 - syntax conventions, 3-1
- UNBIND, 3-99
- UNLOAD, 3-100
- UPDATE FUNCTIONS, 3-101
- UPDATE SYSTEM, 3-102
- UPDATE VXT, 3-106
- VERIFY, 3-107
 - wildcard matching, 3-1
- ZERO ALL, 3-108
- ZERO ETHERNET, 3-109
- ZERO LAT, 3-110
- ZERO MOP, 3-111
- ZERO SERVER, 3-112
- ZERO TAPE, 3-113

Compact discs

- assigning multiple service names, 4-3
- automatic mounting of, 2-3
- automounting, 3-39
- creating services for special volume labels, 2-9
- external
 - creating services for, 4-5
 - formats for automatic serving, 1-2
 - recording, 4-14
 - serving to different operating systems, 4-3
 - serving updated compact discs, 4-2

Connecting to InfoServer system

- from remote terminal, 1-5
- from local console terminal, 1-4

Console terminal, 1-4

- clearing the screen, 3-7
- local
 - troubleshooting access to, 5-9
- remote
 - troubleshooting access to, 5-11

Conventions, x

COPY command, 3-8

Counters

resetting

Ethernet, 3-109

MOP, 3-111

server, 3-108, 3-112

tape, 3-113

CRASH command, 3-10

Crash dump

disabling, 3-42

enabling, 3-42

CREATE PARTITION command, 3-11

CREATE SERVICE command, 3-13

Creating MOP partitions for downline

loading, 4-10

Creating partitions, 3-11, 4-4, 4-5, 4-10

Creating services, 2-9, 3-13, 4-2, 4-3, 4-4,

4-5, 4-6, 4-8, 4-10, 4-12, 4-14

D

DELETE PARTITION command, 3-17

DELETE SERVICE command, 3-18

Device

automatic serving, 1-4

availability, 1-4

backing up, 3-4, 3-33

binding, 3-6

disabling automount, 1-4

disabling automout, 3-37

disabling MOP downline loading, 3-37

displaying device information, 3-64

enabling automout, 3-37

enabling MOP downline loading, 3-37

load balancing, 1-4

names, 2-10

retrieving, 3-4, 3-33

SHOW DEVICE command, 3-63

unbinding, 3-99

unsupported, 5-18

volume label, 2-3

DISCONNECT command, 3-20

Disk

defragmenting, 4-8

formatting, 3-24

Disk (cont'd)

nightly updates, 3-59

partitions, 2-4

BOOT_PARTITION, 2-5

CONFIGURATION, 2-5

IS_FUNCTIONS, 2-5

2NDARY_CONFIGURATION, 2-5

read/write disk, 2-4

replicating, 4-9

verifying, 3-107

write access, 3-59

Displaying InfoServer system information

and counters, 3-85, 3-96

Downline loading, 2-13

by Ethernet address, 1-2, 4-11

by file name, 1-2, 4-10

displaying errors and counters, 3-79

feature, 1-2

partitions for, 4-10

SET SERVER MOP command, 3-50

troubleshooting, 5-21

E

Ending a session, 1-6

ERASE command, 3-21

Error messages, B-3 to B-7

Errors

Ethernet, 3-67

LASTport protocol, 3-67

LAT protocol, 3-74

MOP protocol, 3-78, 3-79

Ethernet

displaying errors and counters, 3-67

EXIT command, 3-22

EXTENSION timer

SET SERVER EXTENSION command,
3-44

External read/write disk, 4-5

F

- File server, 1-1
- Functions
 - updating, 2-4, 3-101

G

- Group codes
 - specifying, 3-45

H

- Hardware failure, 5-18
- Help, 1-7
 - problems with online help, 5-19
- HELP command, 3-23

I

- Identification string for server, 3-47
- Informational messages, B-2 to B-3
- Initial System Load
 - See ISL
- INITIALIZE command, 3-24
- ISL
 - for OpenVMS systems, 1-2
 - MOP downline load files, 1-2
 - Standalone Backup, 1-2

L

- Labels, 2-3
- LAN networks
 - downline loads useful for, 2-13
- LASTport groups, 3-48
 - assigning numbers to, 3-48
- LASTport protocol, 2-1, 3-72
 - displaying errors and counters, 3-67
- LASTport/Disk protocol, 2-1, 2-2
- LASTport/Tape protocol, 2-1, 2-3
- LAT protocol
 - counters
 - resetting, 3-110

LAT protocol (cont'd)

- displaying errors and counters, 3-74
- displaying InfoServer characteristics, 3-74
- displaying LAT terminal server sessions information, 3-77
- identifying InfoServer systems, 3-47
- specifying group codes, 3-45
- LAT Responder function, 3-49
- LAT terminal server, 1-5
 - and LAT Responder function, 3-49
 - connecting to InfoServer system, 3-53, 3-54, 3-58
 - counters, 3-73
 - disconnecting session, 3-20
 - exiting session, 3-22
 - remote management interface, 3-52
 - resetting counters, 3-110
 - services, 3-49
 - sessions, 3-73, 3-77
 - specifying group codes, 3-45
- LATport session
 - disconnecting, 3-20
- License enforcement, 4-14
- Load balancing, 1-4, 2-2, 2-7
- LOOP command, 3-25
- Loop messages, 2-13

M

- Maintenance operation protocol
 - See MOP
- Managing the server
 - ending a session, 1-6
 - ending session, 3-22
 - starting a session, 1-4
- Messages, B-1 to B-8
 - error, B-3 to B-7
 - format, B-1
 - informational, B-2 to B-3
 - types, B-1
 - warning, B-8
- MONITOR command, 3-26

MOP

See also Protocols

MOP protocol

displaying errors and counters, 3-78, 3-79

downline loading, 1-2, 2-13

by Ethernet address, 4-11

partitions for, 4-10

SET SERVER MOP command, 3-50

troubleshooting, 5-21

identity requests, 2-13

loop messages, 2-13

MOP LOOP function, 5-2

read counters, 2-13

Mounting

compact discs, 2-3

tapes, 2-3

Multicast address feature, 2-2

Multicast timer, 3-52

N

Names, 2-8 to 2-11

device, 2-10

InfoServer system, 2-8

partition, 2-9

service, 2-9

NCP command LOOP CIRCUIT, 2-13, 5-2

Nightly updates, 3-59

O

Online help, 1-7, 3-23

not available, 5-19

OpenVMS system

and downline loading, 1-2

P

Partitions, 1-2

automatic installation, 4-12

creating, 4-4

deleting, 3-17

displaying information on, 3-82

for downline loading, 4-10

Partitions (cont'd)

MOP, 2-14, 4-12

names, 2-9

servicing, 4-4

temporary, 4-12

Password

forgetting, 5-26

InfoServer system, 1-5

protecting compact discs, 4-3

setting, 3-54

Prompt

setting, 3-55

Protocols

LASTport, 2-1, 2-2

LASTport/Disk, 2-1

LASTport/Tape, 2-1

MOP, 2-13 to 2-14

PURGE VXT command, 3-27

R

Ratings

for services, 2-7

Read counters, 2-13

Read/write disks

backing up data

locally, 4-6

remotely, 4-7

backing up data from, 4-6

creating partitions on, 4-4

external

creating services for, 4-5

functions, 2-4

partitions, 1-2

Read/write-access policies, 2-12

REBOOT command, 3-28

RECORD command, 3-29

Removing media

service disconnection, 1-4

service reconnection, 1-4

Repeating commands, 3-25

Resetting counters

Ethernet, 3-109

InfoServer, 3-108

LAT, 3-110

MOP, 3-111

Resetting counters (cont'd)

- server, 3-112
- tape, 3-113
- RESTORE command, 3-31
- RETRIEVE command, 3-4, 3-33
- REWIND command, 3-34

S

- SAVE command, 3-35
- SCSI
 - bus, 2-10
 - compact discs, 1-2
 - tapes, 1-2
- Server management session
 - determining default server name, 1-5
 - ending, 1-6, 3-22
 - entering password, 1-5
 - starting, 1-4
- Server name
 - determining, 1-5
- Service class, 2-11
- Service name, 1-5, 2-9
- Service ratings, 2-7, 3-14
- Services
 - creating, 3-13
 - deleted with partitions, 3-17
 - deleting, 3-18
 - displaying information on, 3-91
 - LASTport groups for, 3-48
 - modifying attributes, 3-60
 - names
 - default name, 1-5
 - redundant, 2-9
- Session
 - disconnecting, 3-20
 - ending, 3-22
- SET DEVICE command, 3-37
- SET PARTITION command, 3-38
- SET SERVER AUTOMOUNT command, 3-39
- SET SERVER CACHE BUCKETSIZE command, 3-40
- SET SERVER CACHE SIZE command, 3-41
- SET SERVER CRASHDUMP command, 3-42
- SET SERVER EXTENSION command, 3-44
- SET SERVER GROUP command, 3-45
- SET SERVER IDENTIFICATION command, 3-47
- SET SERVER LASTPORT GROUP command, 3-48
- SET SERVER LAT_RESPONDER command, 3-49
- SET SERVER MOP command, 3-50
- SET SERVER MULTICAST command, 3-52
- SET SERVER NAME command, 3-53
- SET SERVER PASSWORD command, 3-54
- SET SERVER PROMPT command, 3-55
- SET SERVER REMOTE command, 3-56
- SET SERVER STATE command, 3-58
- SET SERVER WRITE ACCESS command, 3-59
- SET SERVICE command, 3-60
- Setting server cache bucket size, 3-40
- Setting server cache size, 3-41
- SHOW DEVICE command, 3-63
 - display fields, 3-63
 - to determine volume labels, 2-4
- SHOW ETHERNET command, 3-66
 - display fields, 3-66
- SHOW FUNCTIONS command, 3-71
- SHOW LAST command, 3-72
- SHOW LAT command, 3-73
 - display fields, 3-74, 3-77
- SHOW MOP command, 3-78
 - display fields, 3-78
- SHOW PARTITIONS command, 3-82
 - display fields, 3-84
- SHOW SERVER command, 3-85
 - characteristics display fields, 3-87
 - counters display fields, 3-88
 - statistics display fields, 3-89
- SHOW SERVICE command, 3-91
 - display fields, 3-93
- SHOW TAPE command, 3-96
 - display fields, 3-97

Small Computer System Interface

See SCSI

Software problems, 5-16

Starting a session, 1-4

System

messages, B-1

saving, 3-35

updating software, 3-102

T

Tape

automatic serving, 1-2

rewinding, 3-34

unloading, 3-100

Terminal

See Console terminal

Terminal server TEST LOOP command,
2-13

TEST LOOP command, 2-13

Transport, 2-2

Troubleshooting, 5-1 to 5-27

cannot connect to InfoServer device, 5-1

entering InfoServer commands

local console, 5-9

remote console, 5-11

forgotten InfoServer password, 5-26

InfoServer does not downline load

systems, 5-21

InfoServer software does not boot, 5-16

online help not available, 5-19

partial boot, 5-19

slow access to InfoServer disks, 5-8

U

UNBIND command, 3-99

UNLOAD command, 3-100

UPDATE FUNCTIONS command, 3-101

UPDATE SYSTEM command, 3-102

UPDATE VXT command, 3-106

Updating functions, 3-101

Updating InfoServer software, 3-102

Updating VXT software, 3-106

V

VAX system

downline loading, 1-2

VERIFY command, 3-107

Virtual device

slow access, 5-8

troubleshooting connections, 5-1

Virtual device server, 1-1

Volume label, 2-3

determining, 2-4

VXT software

purging, 3-27

updating, 3-106

W

Warning messages, B-8

Write access, 3-59

blocking, 2-12, 3-59

pre-emptive, 2-12, 3-59

X

X terminal client

accessing font services, 2-6

configuring, 4-12

downline loading system software, 2-6

paging memory, 2-6

saving configuration information, 2-6

Z

ZERO ALL command, 3-108

ZERO ETHERNET command, 3-109

ZERO LAT command, 3-110

ZERO MOP command, 3-111

ZERO SERVER command, 3-112

ZERO TAPE command, 3-113

How to Order Additional Documentation

Technical Support

If you need help deciding which documentation best meets your needs, call 800-DIGITAL (800-344-4825) and press 2 for technical assistance.

Electronic Orders

If you wish to place an order through your account at the Electronic Store, dial 800-234-1998, using a modem set to 2400- or 9600-baud. You must be using a VT terminal or terminal emulator set at 8 bits, no parity. If you need assistance using the Electronic Store, call 800-DIGITAL (800-344-4825) and ask for an Electronic Store specialist.

Telephone and Direct Mail Orders

From	Call	Write
U.S.A.	DECdirect Phone: 800-DIGITAL (800-344-4825) FAX: (603) 884-5597	Digital Equipment Corporation P.O. Box CS2008 Nashua, NH 03061
Puerto Rico	Phone: (809) 781-0505 FAX: (809) 749-8377	Digital Equipment Caribbean, Inc. 3 Digital Plaza, 1st Street Suite 200 Metro Office Park San Juan, Puerto Rico 00920
Canada	Phone: 800-267-6215 FAX: (613) 592-1946	Digital Equipment of Canada Ltd. 100 Herzberg Road Kanata, Ontario, Canada K2K 2A6 Attn: DECdirect Sales
International	_____	Local Digital subsidiary or approved distributor
Internal Orders ¹ (for software documentation)	DTN: 241-3023 (508) 874-3023	Software Supply Business (SSB) Digital Equipment Corporation 1 Digital Drive Westminster, MA 01473
Internal Orders (for hardware documentation)	DTN: 234-4325 (508) 351-4325 FAX: (508) 351-4467	Publishing & Circulation Services Digital Equipment Corporation NR02-2 444 Whitney Street Northboro, MA 01532

¹Call to request an Internal Software Order Form (EN-01740-07).

Reader's Comments

InfoServer
System Operations Guide

AA-PJXJC-TE

Your comments and suggestions help us improve the quality of our publications.
Thank you for your assistance.

I rate this manual's:	Excellent	Good	Fair	Poor
Accuracy (product works as manual says)	<input type="checkbox"/>	<input type="checkbox"/>	<input type="checkbox"/>	<input type="checkbox"/>
Completeness (enough information)	<input type="checkbox"/>	<input type="checkbox"/>	<input type="checkbox"/>	<input type="checkbox"/>
Clarity (easy to understand)	<input type="checkbox"/>	<input type="checkbox"/>	<input type="checkbox"/>	<input type="checkbox"/>
Organization (structure of subject matter)	<input type="checkbox"/>	<input type="checkbox"/>	<input type="checkbox"/>	<input type="checkbox"/>
Figures (useful)	<input type="checkbox"/>	<input type="checkbox"/>	<input type="checkbox"/>	<input type="checkbox"/>
Examples (useful)	<input type="checkbox"/>	<input type="checkbox"/>	<input type="checkbox"/>	<input type="checkbox"/>
Index (ability to find topic)	<input type="checkbox"/>	<input type="checkbox"/>	<input type="checkbox"/>	<input type="checkbox"/>
Page layout (easy to find information)	<input type="checkbox"/>	<input type="checkbox"/>	<input type="checkbox"/>	<input type="checkbox"/>

I would like to see more/less _____

What I like best about this manual is _____

What I like least about this manual is _____

I found the following errors in this manual:

Page	Description
_____	_____
_____	_____
_____	_____

Additional comments or suggestions to improve this manual:

For software manuals, please indicate which version of the software you are using: _____

Name/Title _____ Dept. _____

Company _____ Date _____

Mailing Address _____

_____ Phone _____

- Do Not Tear - Fold Here and Tape -



No Postage
Necessary
If Mailed
in the
United States

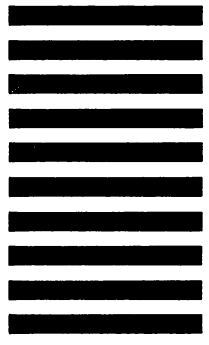

BUSINESS REPLY MAIL
FIRST CLASS PERMIT NO. 33 MAYNARD MASS.

POSTAGE WILL BE PAID BY ADDRESSEE

DIGITAL EQUIPMENT CORPORATION
Information Design and Consulting
PKO3-2/P33
129 Parker Street
Maynard, MA 01754-9975



- Do Not Tear - Fold Here -