

# **DECstation 2100/3100**

---

## Operator's Guide

---

June 1989

The information in this document is subject to change without notice and should not be construed as a commitment by Digital Equipment Corporation. Digital Equipment Corporation assumes no responsibility for any errors that may appear in this document.

The software described in this document is furnished under a license and may be used or copied only in accordance with the terms of such license.

Digital Equipment Corporation assumes no responsibility for the use or reliability of its software on equipment that is not supplied by Digital or its affiliated companies.

© Digital Equipment Corporation 1989.  
All Rights Reserved  
Printed in U.S.A.

---

USA

This equipment generates, uses, and may emit radio frequency energy. The equipment has been type tested and found to comply with the limits for a Class A computing device pursuant to Subpart J of Part 15 of FCC Rules, which are designed to provide reasonable protection against such radio frequency interference. Operation of this equipment in a residential area may cause interference in which case the user at his own expense will be required to take whatever measures may be required to correct the interference.

---

The following are trademarks of Digital Equipment Corporation:

DEC	ULTRIX	VMS
DECnet	ULTRIX-32	VT
DECstation	UNIBUS	
DECUS	VAX	
MicroVAX	VAXBI	
MicroVMS	VAXcluster	
PDP	VAXstation	

**digital**<sup>™</sup>

---

# Contents

Using This Guide .....	xi
------------------------	----

## 1 Basic DECstation 2100/3100 Hardware

The System Unit .....	1-2
The Monitor .....	1-5
Adjusting the Position of the Monitor .....	1-10
For both 15-inch monitors .....	1-10
For the 19-inch color monitor .....	1-11
The Keyboard .....	1-12
Adjusting the Keyboard .....	1-12
The Mouse .....	1-13
Cleaning the Mouse .....	1-14

## 2 Hardware Options

Adding Memory .....	2-1
To Add Memory Modules .....	2-1
Adding Storage .....	2-2
To Add Storage Devices .....	2-2
Adding a Printer .....	2-3
To Add a Printer .....	2-3
Adding a Modem .....	2-4
To Add a Modem .....	2-4

### 3 Using DECstation 2100/3100 Hardware

Turning On Your Workstation . . . . .	3-2
For a Workstation on a Power Strip . . . . .	3-2
For a Workstation Not on a Power Strip . . . . .	3-3
Turning Off Your Workstation . . . . .	3-5
For a Workstation on a Power Strip . . . . .	3-5
For a Workstation Not on a Power Strip . . . . .	3-5
Using the Configuration Display . . . . .	3-6
To Display Your Workstation Configuration . . . . .	3-6
Using Console Commands . . . . .	3-8
Booting the Worksystem Software . . . . .	3-8
Setting the Workstation for Automatic Booting . . . . .	3-9
Shutting Down the Worksystem Software . . . . .	3-10

### 4 Using the Tape Drive

Checking the Position of the Tape Leader Inside a Cartridge . . . . .	4-2
Write-Protecting a Cartridge . . . . .	4-4
Write-Enabling a Cartridge . . . . .	4-5
Checking the Take-Up Leader Inside the Drive . . . . .	4-6
Loading a Tape Cartridge . . . . .	4-7
Removing a Tape Cartridge . . . . .	4-12
Labeling a Tape Cartridge . . . . .	4-15

### 5 Using the Optical Compact Disc Drive

Connectors, Controls, and Indicator Lights on the Disc Drive . . . . .	5-2
Using an Optical Compact Disc Drive . . . . .	5-4
To Load a Disc into a Drive . . . . .	5-5
To Unload a Disc from a Drive . . . . .	5-8
Handling Compact Discs . . . . .	5-9
To Unload a Disc from Its Caddy . . . . .	5-10
To Load a Disc into Its Caddy . . . . .	5-12
Cleaning a Compact Disc . . . . .	5-15
For Further Information . . . . .	5-15

## 6 Troubleshooting

Using the Self-Test .....	6-2
If a Subtest Fails .....	6-3
If Subtest 7, 6, 5, or 4 Fails .....	6-4
If Subtest 3 Fails .....	6-4
If Subtest 2 Fails .....	6-5
For a workstation not on a network .....	6-5
For a workstation on ThickWire Ethernet .....	6-6
For a workstation on ThinWire Ethernet .....	6-7
If Subtest 1 Fails .....	6-8
For a workstation with no external storage devices .....	6-8
For a workstation with external storage devices .....	6-9
Solving Hardware Problems .....	6-10
Contacting Your Digital Service Representative .....	6-17

## 7 Moving the DECstation 2100/3100 Workstation

Dismantling the Workstation .....	7-2
Packing Your Equipment .....	7-3
Reinstalling Your DECstation 2100/3100 .....	7-3

## A Equipment Specifications

## B Part Numbers

## C Console Commands

Conventions Used in This Appendix .....	C-3
Getting Help .....	C-4
Console Commands .....	C-5
The auto Command .....	C-6
The boot Command .....	C-6
The ctrs Command .....	C-8
The d (deposit) Command .....	C-9
The disable Command .....	C-10
The dump Command .....	C-10
The e (examine) Command .....	C-12
The enable Command .....	C-13

The fill Command .....	C-14
The go Command .....	C-15
The help Command .....	C-15
The ? Command .....	C-15
The init Command .....	C-16
The printenv Command .....	C-16
The setenv Command .....	C-20
The test Command .....	C-20
The unsetenv Command .....	C-21

## D Interpreting the Self-Test

Using the Power-Up Self-Test .....	D-1
Interpreting Monitor Self-Test Codes .....	D-2
Interpreting LED Self-Test Codes .....	D-3

## Index

## Figures

1-1	The basic DECstation 2100/3100 hardware .....	1-1
1-2	The back of the system unit .....	1-2
1-3	System unit icons .....	1-4
1-4	Monitor icons .....	1-5
1-5	The 15-inch monochrome monitor .....	1-6
1-6	The 15-inch color monitor .....	1-7
1-7	The 19-inch monochrome monitor .....	1-8
1-8	The 19-inch color monitor .....	1-9
1-9	The keyboard .....	1-12
1-10	The mouse .....	1-13
1-11	Removing the tracking ball from the mouse .....	1-14
2-1	Expansion boxes .....	2-2
3-1	Sample configuration display .....	3-6
4-1	The tape drive .....	4-1
4-2	Opening the door on the cartridge .....	4-2
4-3	A tape leader positioned correctly in the cartridge .....	4-3
4-4	A write-protected cartridge .....	4-4
4-5	A write-enabled cartridge .....	4-5
4-6	A take-up leader positioned correctly in the drive .....	4-6

4-7	Pressing the load/unload button on a tape drive .....	4-7
4-8	Lifting the insert/release handle on a tape drive .....	4-8
4-9	Inserting a tape drive .....	4-9
4-10	Lowering the insert/release handle on a tape drive .....	4-10
4-11	Pressing the load/unload button on a tape drive .....	4-12
4-12	Lifting the insert/release handle on a tape drive .....	4-13
4-13	Removing a tape cartridge .....	4-14
4-14	Labeling a tape cartridge .....	4-15
5-1	The optical compact disc drive .....	5-1
5-2	Connectors, controls, and indicator lights on the drive .....	5-2
5-3	The parts of a disc caddy .....	5-4
5-4	Turning on the drive .....	5-5
5-5	Positioning the caddy .....	5-6
5-6	Inserting the caddy .....	5-7
5-7	Positioning the protective sleeve .....	5-8
5-8	A compact disc .....	5-9
5-9	Beginning to remove the frame .....	5-10
5-10	Holding the disc .....	5-11
5-11	Positioning the disc .....	5-12
5-12	Positioning the frame .....	5-13
5-13	Placing the disc inside the frame .....	5-14
5-14	Inserting the disc and frame into the sleeve .....	5-14
6-1	The on/off switch and reset button on the system unit .....	6-2
6-2	Checking the mouse and keyboard connections .....	6-4
6-3	Checking Ethernet connections .....	6-5
6-4	Checking ThickWire connections .....	6-6
6-5	Checking ThinWire connections .....	6-7
6-6	Checking the SCSI terminator .....	6-8
6-7	Checking SCSI connections .....	6-9

## Tables

1	Conventions Used in This Guide .....	xi
1-1	Connectors, Controls, and Indicator Lights on the System Unit .....	1-3
1-2	Controls, Connectors, and Indicator Lights on the Monitors .....	1-10
3-1	Shutdown Commands .....	3-10

5-1	Connectors, Controls, and Indicator Lights on the Disc Drive .....	5-3
6-1	Solutions to Common Hardware Problems .....	6-10
A-1	System Unit Description .....	A-2
A-2	System Unit Operating Conditions .....	A-2
A-3	System Specifications .....	A-2
A-4	System Unit Nonoperating Conditions .....	A-2
A-5	VR150 Monitor Description .....	A-3
A-6	VR150 Monitor Specifications .....	A-3
A-7	VR150 Monitor Operating Conditions .....	A-4
A-8	VR150 Monitor Nonoperating Conditions .....	A-5
A-9	VR160 Monitor Description .....	A-6
A-10	VR160 Monitor Specifications .....	A-6
A-11	VR160 Monitor Operating Conditions .....	A-7
A-12	VR160 Monitor Nonoperating Conditions .....	A-7
A-13	VR262 Monitor Description .....	A-8
A-14	VR262 Monitor Specifications .....	A-8
A-15	VR262 Monitor Operating Conditions .....	A-9
A-16	VR262 Monitor Nonoperating Conditions .....	A-10
A-17	VR299 Monitor Description .....	A-11
A-18	VR299 Monitor Specifications .....	A-11
A-19	VR299 Monitor Operating Conditions .....	A-13
A-20	VR299 Monitor Nonoperating Conditions .....	A-13
A-21	LK201 Keyboard Description .....	A-14
A-22	LK201 Keyboard Specifications .....	A-14
A-23	LK201 Keyboard Operating Conditions .....	A-14
A-24	LK201 Keyboard Nonoperating Conditions .....	A-15
A-25	VSXXX-AA Mouse Description .....	A-16
A-26	VSXXX-AA Mouse Specifications .....	A-16
A-27	VSXXX-AA Mouse Operating Conditions .....	A-16
A-28	VSXXX-AA Mouse Nonoperating Conditions .....	A-17
A-29	RZ55 SCSI Hard Disk Drive Description .....	A-18
A-30	RZ55 SCSI Hard Disk Drive Specifications .....	A-18
A-31	RZ55 SCSI Hard Disk Drive Operating Conditions .....	A-19
A-32	RZ55 SCSI Hard Disk Drive Nonoperating Conditions .....	A-19
A-33	TK50Z Tape Drive Description .....	A-20
A-34	TK50Z Tape Drive Specifications .....	A-20
A-35	TK50Z Tape Drive Operating Conditions .....	A-20
A-36	TK50Z Tape Drive Nonoperating Conditions .....	A-21

A-37	RRD40 Compact Disc Drive Description (Tabletop) .....	A-22
A-38	RRD40 Compact Disc Drive Specifications (Tabletop) .....	A-22
A-39	RRD40 Compact Disc Drive Operating Conditions (Tabletop) .....	A-22
A-40	RRD40 Compact Disc Drive Nonoperating Conditions (Tabletop) .....	A-22
A-41	RZ23 SCSI Hard Disk Drive Description .....	A-23
A-42	RZ23 SCSI Hard Disk Drive Specifications (formatted) .....	A-23
A-43	RZ23 SCSI Hard Disk Drive Operating Conditions .....	A-23
A-44	RZ23 SCSI Hard Disk Drive Nonoperating Conditions .....	A-24
B-1	Basic Components .....	B-1
B-2	Cords, Cables, and Connectors .....	B-2
B-3	Software Documentation .....	B-3
B-4	Hardware Documentation .....	B-3
C-1	Console Commands .....	C-5
C-2	Default Environment Variables .....	C-17
D-1	Monitor Self-Test Display Codes .....	D-2
D-2	LED Self-Test Display Codes .....	D-3

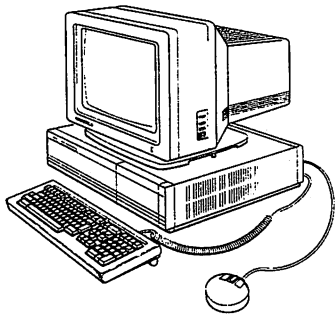

---

# Using This Guide

Use this guide to learn to use and troubleshoot your DECstation 2100/3100 hardware.

This guide tells you

- How to use the connectors, controls, and indicator lights on your workstation hardware
- How to adjust your workstation hardware for your comfort
- What options you can use to increase your workstation's performance
- How to use a tape drive
- How to diagnose and solve hardware problems
- How to dismantle and pack your workstation in preparation for moving

**Table 1. Conventions Used in This Guide**

<b>Convention</b>	<b>Use</b>
Monospace type	Anything that appears on your monitor screen is set in monospace, like this.
<b>Boldface type</b>	<b>Anything you are asked to type is set in boldface, like this.</b>
	<i>Note:</i> All commands typed at the console level are case sensitive. The workstation does not recognize uppercase and lowercase letters as the same input.

---

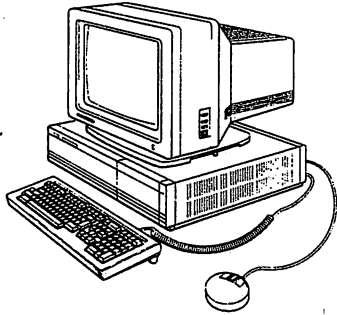

---

## Basic DECstation 2100/3100 Hardware

This chapter describes the four basic parts of the DECstation 2100/3100 workstation: the system unit, monitor, keyboard, and mouse.

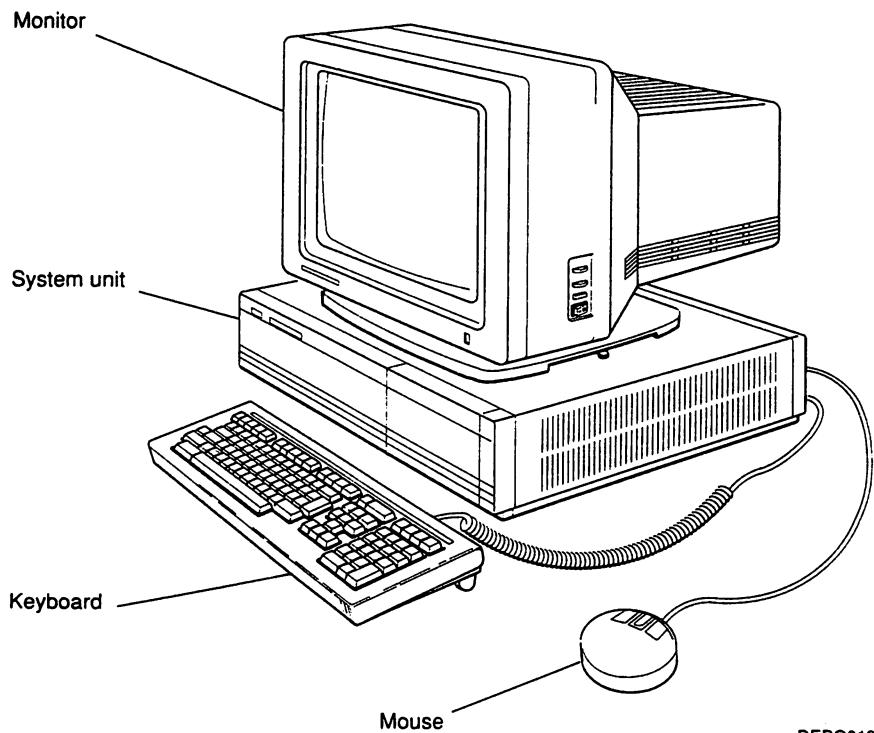

DEPG018

Figure 1-1. The basic DECstation 2100/3100 hardware

## The System Unit

The system unit is designed to sit flat on your desk with the monitor placed on top of or next to it.

**Caution:** *Standing the system unit on its side blocks vents and can damage the unit.*

If you look at the back of the system unit, you can see, starting in the upper-left corner and moving from left to right, the connectors, controls, and indicator lights pictured in Figure 1-2 and described in Table 1-1. Figure 1-3 shows the icons that appear on the system unit.

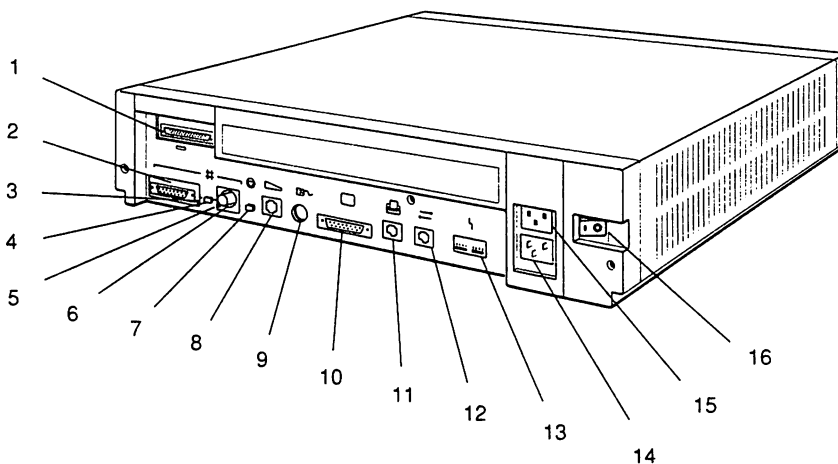

- |                                       |   |
|---------------------------------------|---|
| 1. SCSI connector                     | 9. Mouse connector                      |
| 2. ThickWire Ethernet connector       | 10. Monitor connector                   |
| 3. ThickWire Ethernet indicator light | 11. Printer connector                   |
| 4. Ethernet button                    | 12. Communications connector            |
| 5. ThinWire Ethernet indicator light  | 13. Diagnostic indicator lights         |
| 6. ThinWire Ethernet connector        | 14. System unit power connector         |
| 7. Reset button                       | 15. Monitor-system unit power connector |
| 8. Keyboard connector                 | 16. On/off switch                       |

DEPG019

**Figure 1-2.** The back of the system unit

**Table 1-1. Connectors, Controls, and Indicator Lights on the System Unit**

<b>Item</b>	<b>Function</b>
SCSI connector	The point at which external small computer system interface (SCSI) storage devices connect to the system unit. If you have no such devices, this connector must be covered with a terminator.
ThickWire connector	The point at which ThickWire Ethernet connects to the system unit.
ThickWire light	Glowes green on a workstation selected for ThickWire Ethernet.
Ethernet button	Activates your ThinWire or ThickWire Ethernet connection.  When your workstation is connected to ThickWire Ethernet, the light to the right of the ThickWire Ethernet connector glows green.  When your workstation is connected to ThinWire Ethernet, the light to the left of the ThinWire T-connector glows green.
ThinWire light	Glowes green on a workstation selected for ThinWire Ethernet.
ThinWire connector	The point at which ThinWire Ethernet connects to the system unit.
Reset button	Returns you to the console prompt.
Keyboard connector	The point at which the keyboard connects to the system unit.
Mouse connector	The point at which the mouse connects to the system unit.
Monitor connector	The point at which the video cable connects the monitor to the system unit.
Printer connector	The point at which a printer connects to the system unit.
Communications connector	The point at which a communications device connects to the system unit.
Diagnostic lights	Indicate where system failures occurred.
System unit power connector	The point at which power from the power source reaches the system unit.
Monitor-system unit power connector	The point at which power passes from the system unit to the monitor.
On/off switch	Turns the system unit on and off. Pressing the 1 turns the system on. Pressing the 0 turns it off.

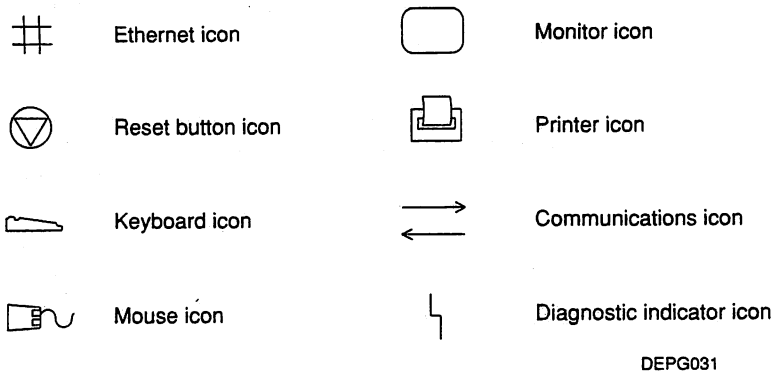

**Figure 1-3. System unit icons**

## The Monitor

**Caution:** *Connecting or disconnecting your monitor while power is turned on can damage the monitor.*

Your DECstation 2100/3100 came with one of the following:

- VR150 15-inch monochrome monitor
- VR160 15-inch color monitor
- VR262 19-inch monochrome monitor
- VR299 19-inch color monitor

Connectors, controls, and indicator lights are located in different places on the different monitors. Look at the illustration of your monitor to see where to find them.

Figure 1-4 shows the icons that appear on the monitors. Figures 1-5 through 1-8 show the various monitors. Table 1-2 describes the controls, connectors, and indicator lights on the monitors.



Contrast icon

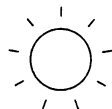

Brightness icon



Degauss icon

DEPI023

**Figure 1-4. Monitor icons**

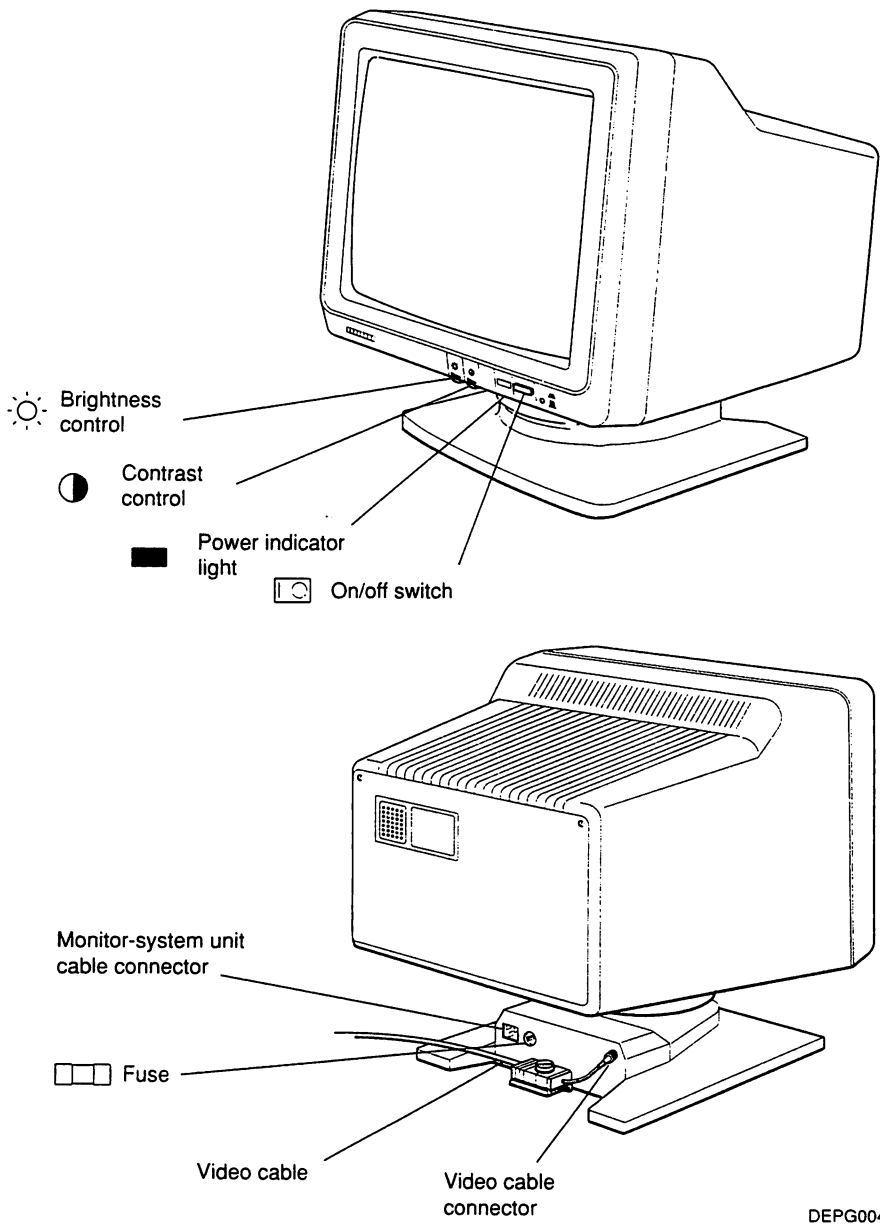

DEPG004

Figure 1-5. The 15-inch monochrome monitor

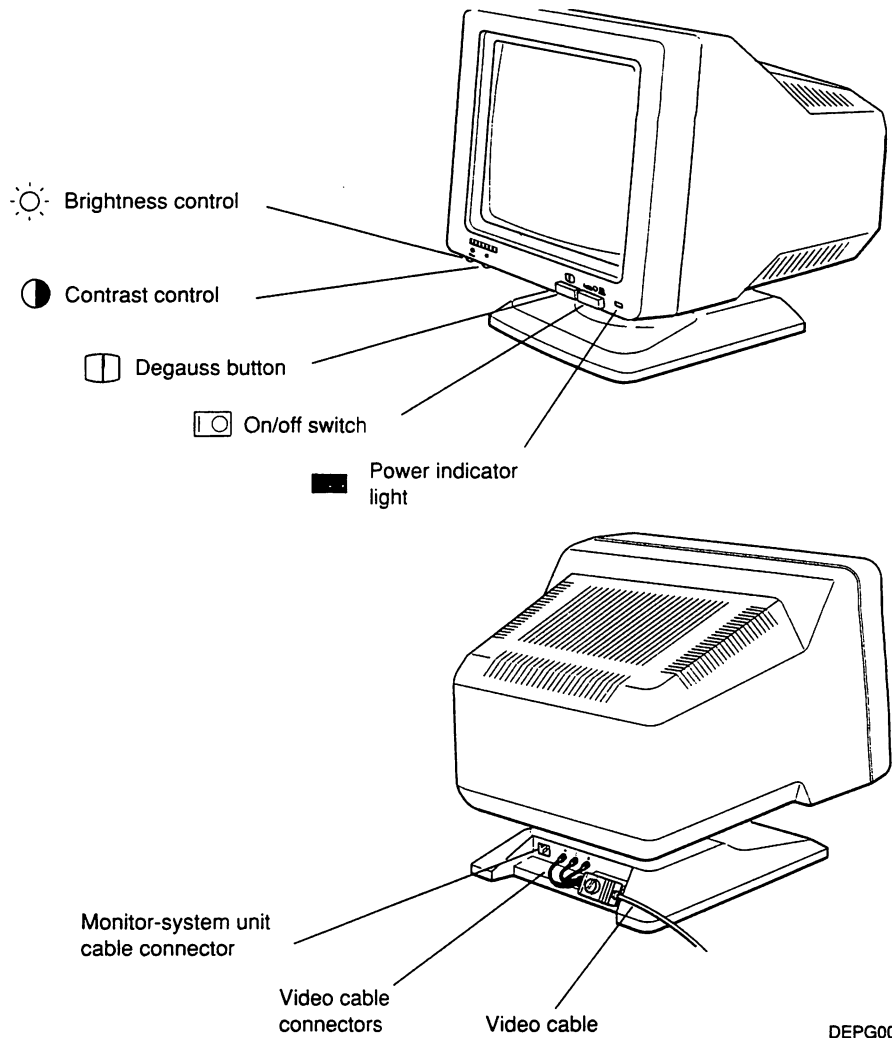

DEPG005

Figure 1-6. The 15-inch color monitor

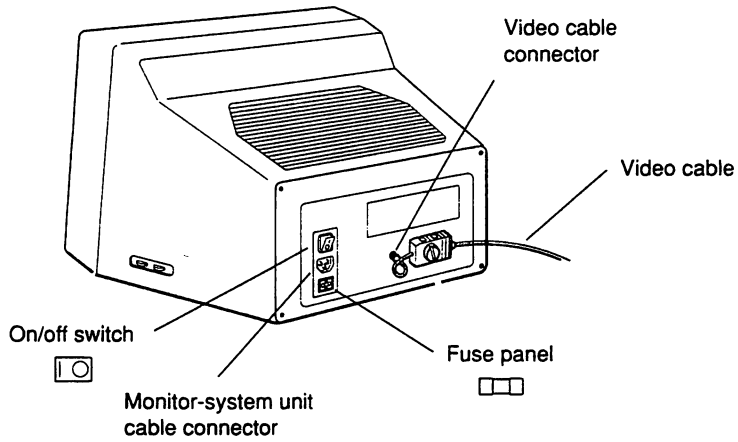
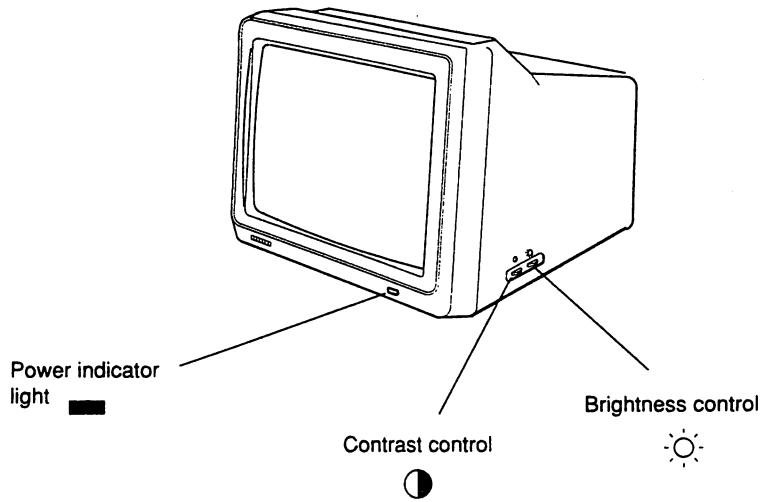

DEPG006

Figure 1-7. The 19-inch monochrome monitor

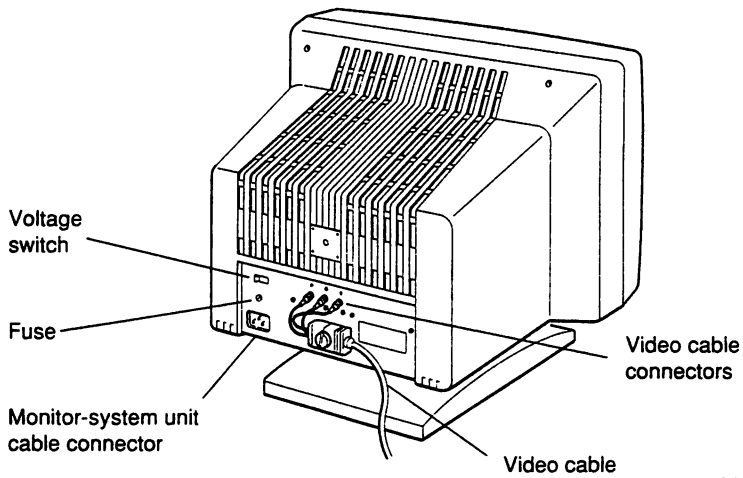
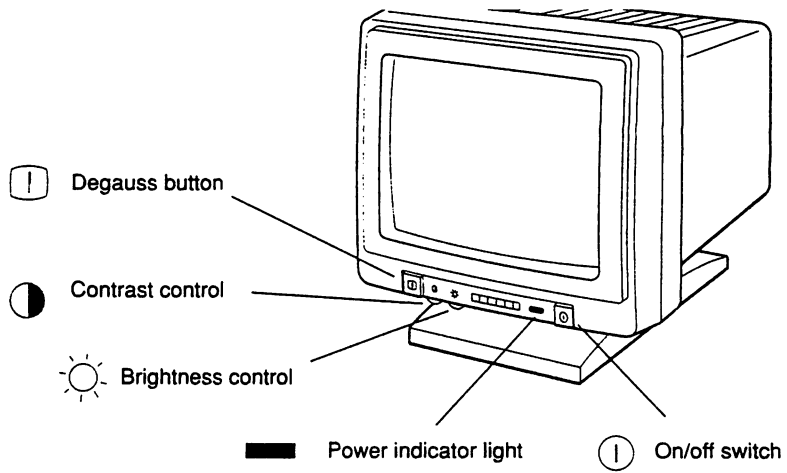

DEPG007

**Figure 1-8. The 19-inch color monitor**

**Table 1-2. Controls, Connectors, and Indicator Lights on the Monitors**

Item	Function
Power indicator light	Glows green when the monitor receives power from the system unit.
Contrast control	Allows you to adjust the intensity of the display on your screen.
Brightness control	Allows you to adjust the brightness of the background on the screen.
Video cable	Allows video signals to flow between the monitor and the system unit. (Monochrome monitors have one connector; color monitors have three.)
Fuse	Protects the monitor from electrical damage.
Voltage switch	On the 19-inch monochrome monitor, lets you match the monitor's voltage to the voltage at your power source.
Monitor-system unit cable connector	Allows power to flow from the system unit to the monitor.
On/off switch	Turns the monitor on and off.
Degauss button	On color monitors, lets you clear color distortion caused by outside magnetic interference.
Tilt-lock lever	On the 19-inch color monitor, lets you adjust the tilt of the monitor and then lock it into the position you have chosen.

## Adjusting the Position of the Monitor

**Caution:** *Swiveling the monitor in a complete circle can damage the base.*

All monitors except the 19-inch monochrome monitor can be tilted and swiveled into the position that is most comfortable for you.

### For both 15-inch monitors

The 15-inch monochrome and color monitors both come with built-in tilt-swivel stands that do not lock into place.

To set the angle of your monitor, slowly tilt the monitor forward or backward to the desired position.

You can turn the monitor from side to side without changing the tilt angle.

### For the 19-inch color monitor

The 19-inch color monitor comes with a built-in tilt-swivel mechanism and a tilt-lock lever that locks the monitor into the tilt position you select.

- Push the lever toward the rear of the monitor to unlock the tilting mechanism.
- Pull the lever all the way forward to lock the tilting mechanism. The monitor can be swiveled from side to side at any time; there is no control that locks it into place.

# The Keyboard

**Caution:** *Connecting or disconnecting the keyboard while the system is turned on can damage the keyboard.*

The main part of your keyboard resembles a typewriter keyboard. Your keyboard also has some special function keys. The documentation that came with your software explains how to use these keys.

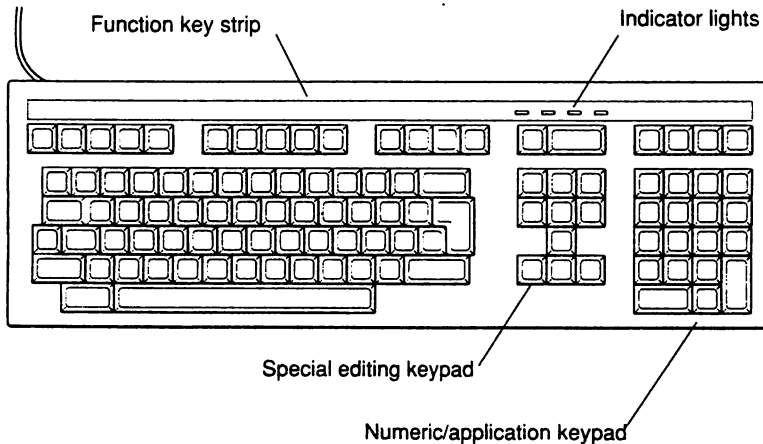

DEPG001

**Figure 1-9.** The keyboard

## Adjusting the Keyboard

Your keyboard is shipped with the cable coming out of the right side. You can adjust the keyboard cable so it comes out of the left side if you prefer. You can also adjust the typing angle of your keyboard.

See the documentation that came with your keyboard for instructions on how to make these adjustments.

## The Mouse

*Caution: Connecting or disconnecting the mouse while the system unit is turned on can damage the mouse.*

The mouse is a hand-held pointing device that lets you easily position the cursor on your screen.

The way you use your mouse depends on the software you use. The documentation that came with your software explains how to use your mouse.

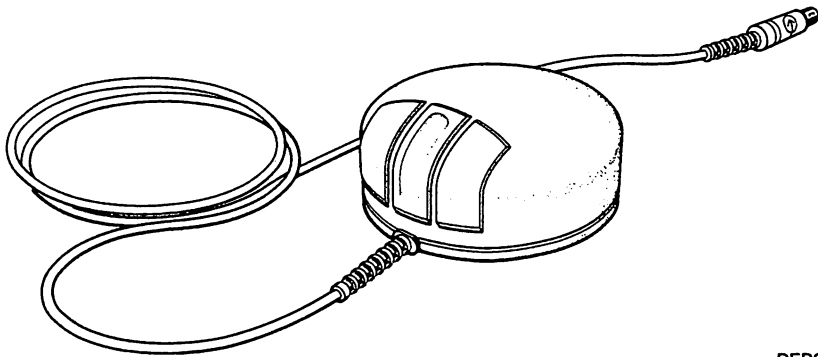

DEPG017

**Figure 1-10. The mouse**

## Cleaning the Mouse

Clean the mouse when it fails to move the cursor smoothly on the screen.

To clean the mouse,

1. Turn the mouse upside down.
2. Release the round plate from the bottom of the mouse by placing your fingers in the grooves on the plate and turning the plate to the left.
3. Lift off the plate and remove the tracking ball from inside the mouse.

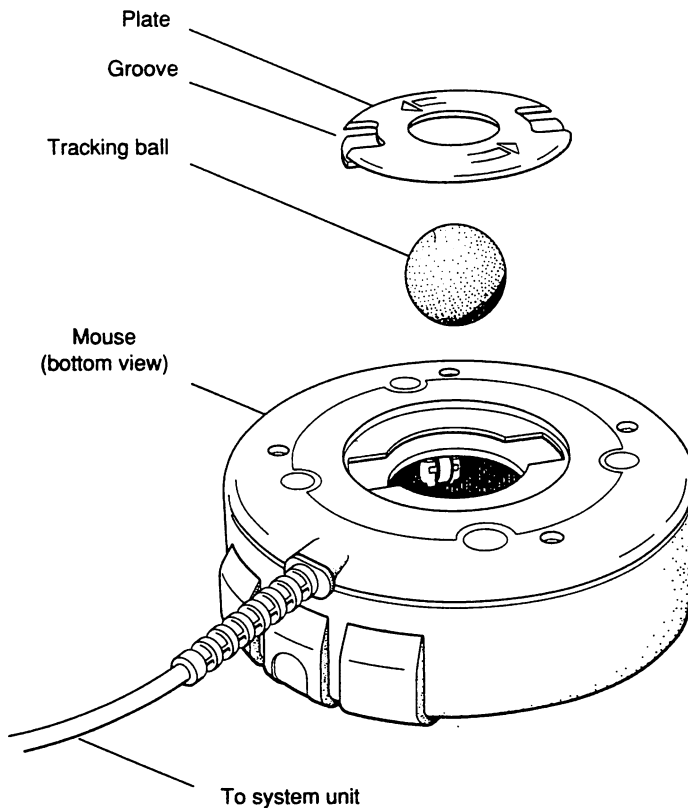

DEPG016

Figure 1-11. Removing the tracking ball from the mouse

4. Wash the ball with lukewarm water and, if necessary, mild soap.

*Caution: Organic solvents, such as toluene or trichlorethane, damage the rubber coating.*

5. Dry the ball with a soft, lint-free cloth.
6. Replace the ball by reversing steps 3 and 2.

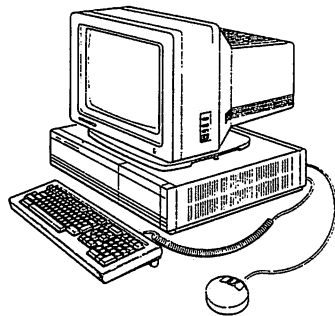

---

## Hardware Options

This chapter tells you

- What memory and storage options are available for the DECstation 2100/3100 workstation and how to get them installed
- What printers and modems are available for your system and where to learn how to install them

### Adding Memory

You can add 4-megabyte memory modules to your system unit up to a total of 24 megabytes of memory.

To determine how much memory you can add, use the configuration display described in Chapter 3 of this guide.

#### To Add Memory Modules

To add memory modules, contact your Digital service representative, who will install them for you.

## Adding Storage

Storage devices available for your DECstation 2100/3100 workstation include the following:

- 104-megabyte RZ23 internal hard disk drive
- 332-megabyte RZ55 external hard disk drive
- 95-megabyte TK50Z external tape drive
- 635-megabyte RRD40 external optical compact disc drive

Your workstation can have up to six such storage devices, including one or two internal hard disk drives and up to four external devices.

External devices come preinstalled in expansion boxes (see Figure 2-1).

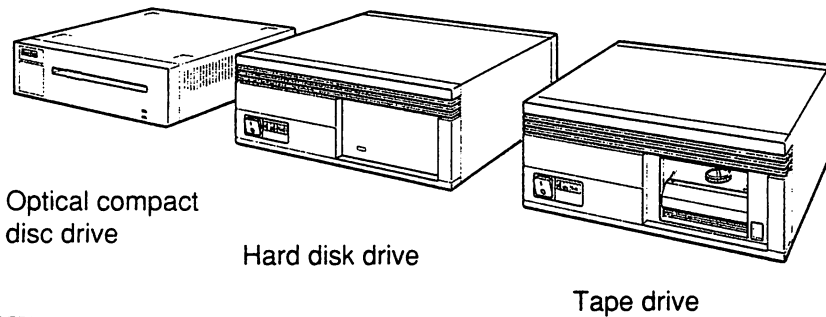

DEPI063

Figure 2-1. Expansion boxes

### To Add Storage Devices

To add internal storage devices, contact your Digital service representative, who will install them for you.

To install external storage devices, follow the instructions in Chapter 4 of the *DECstation 2100/3100 Hardware Installation Guide*, which came in your DECstation 2100/3100 documentation kit.

## Adding a Printer

Printers available for the DECstation 2100/3100 workstation include the following:

**LN03** — A desktop, nonimpact laser printer that produces letter-quality text at a rate of eight pages per minute

**LN03 Plus** — An enhanced LN03 printer that prints documents with both text and graphics

**LN03R Script Printer** — A nonimpact page printer that uses laser recording technology to produce high-quality text, graphics, and images

**LA100** — A desktop dot-matrix printing terminal

**LA75** — A desktop dot-matrix printer with pixel graphics

**LA50** — A desktop dot-matrix printer with bitmap or character-cell graphics

**LJ250 color** — A desktop dot-matrix color printer

**LPS40** — A networked printer that functions as an independent system (or node) in a network

When you order a printer, you may need to order a serial line cable to connect it to your system unit. Your Digital sales representative can tell you what you need.

### To Add a Printer

For instructions on installing a printer, see Chapter 4 of the *DECstation 2100/3100 Hardware Installation Guide*, which came in your DECstation 2100/3100 documentation kit.

## Adding a Modem

Modems available for the DECstation 2100/3100 workstation include the following:

**DF242 Scholar Plus** — A 300/1,200/2,400-bits-per-second, full-duplex asynchronous modem

**DF224** — A 300/1,200/2,400-bits-per-second, full-duplex asynchronous modem

**DF212** — A 300/600/1,200-bits-per-second, full-duplex asynchronous modem

**DF112** — A 300/1,200-bits-per-second, full-duplex asynchronous modem

**DF03** — A 300/1,200-bits-per-second, full-duplex asynchronous modem

Other modems that can be used are described in your software documentation.

When you order your modem, you may need to order a serial line cable with which to connect your modem cable to your system unit. Your Digital sales representative can tell you what you need.

*Note: Auto-answer is not available; data leads only are connected.*

### To Add a Modem

For instructions on installing a modem, see the section on installing communication devices in Chapter 4 of the *DECstation 2100/3100 Hardware Installation Guide*, which came in your DECstation 2100/3100 documentation kit.

---

## Using DECstation 2100/3100 Hardware

This chapter tells you

- How to turn your workstation on and off
- How to interpret and use the configuration display
- About some console commands you might find useful

## Turning On Your Workstation

### For a Workstation on a Power Strip

Turn on the power strip by pressing the raised portion of its on/off switch.

As soon as you turn on the power strip, the following things happen:

- The system unit begins its power-up self-test.
- The power indicator lights on your equipment glow green.

The monitor warms up, and a display similar to the following gradually appears on the screen:

```
KN01 V6.71
7..6..5..4..3..2..1..0
16Mb.....0
```

When testing has been completed successfully, a display similar to the following appears at the bottom of the screen:

```
KN01 V6.71
08-00-2b-0d-f7-6a
0x01000000
>>
```

The >> at the end of this display is the console program prompt. The console program is discussed later in this chapter and in Appendix C.

If the power-up self-test display fails to appear, or if the following line flashes on your screen, turn to Chapter 6 of this guide for troubleshooting instructions.

```
FAILURE - RESET TO CONTINUE
```

## For a Workstation Not on a Power Strip

1. If you have an expansion box, turn it on by pressing the 1 on the on/off switch on the front of the box.
2. Turn on any printer and modem or other communications device by following the instructions that came with it.
3. Turn on the monitor.
  - On a 15-inch monochrome or color monitor, press the on/off switch in the lower-right corner of the front of the monitor.
  - On a 19-inch monochrome monitor, press the 1 on the on/off switch on the back of the monitor.
  - On a 19-inch color monitor, press the on/off switch on the right side of the monitor as you face the screen.

*Note:* After you turn the monitor on for the first time, you use the on/off switch on the system unit to turn the system unit and monitor on and off.

4. Turn on the system unit by pressing the 1 on the on/off switch on the back of the unit.

As soon as you turn on the system unit, the following things happen:

- The system unit begins its power-up self-test.
- The power indicator lights on your equipment glow green.

After about a minute, a display similar to the following gradually appears on the screen.

```
KN01 V6.71
7..6..5..4..3..2..1..0
16Mb.....0
```

When testing has been completed successfully, a display similar to the following appears at the bottom of the screen:

```
KN01 V6.71  
08-00-2b-0d-f7-6a  
0x01000000  
>>
```

The >> at the end of this display is the console program prompt. The console program is discussed later in this chapter and in Appendix C.

If the power-up self-test display fails to appear, or if the following line flashes on your screen, turn to Chapter 6 of this guide for troubleshooting instructions.

```
FAILURE - RESET TO CONTINUE
```

## Turning Off Your Workstation

### For a Workstation on a Power Strip

1. Shut down your operating system by following the instructions in your operating system software documentation.
2. Turn off the power strip by pressing the raised portion of its on/off switch.

### For a Workstation Not on a Power Strip

1. Shut down your operating system by following the instructions in your operating system software documentation.
2. Turn off any printer and modem or other communications device by following the instructions that came with it.
3. If you have an expansion box, turn it off by pressing the 0 on the on/off switch on the box.
4. Turn off the system unit and monitor by pressing the 0 on the on/off switch on the back of the system unit.

## Using the Configuration Display

The configuration display tells you

- How much memory your workstation contains
- Whether your monitor is monochrome or color
- What your Ethernet station address is (you must know this to be able to connect your workstation to a network)
- What storage devices your system has and what units they are assigned to

### To Display Your Workstation Configuration

Type **test -c** at the console prompt (>>) and press Return.

A display similar to the following appears on your screen.

```
MEMORY: 16 Mbytes
VIDEO: MONO
ETHERNET STATION ADDRESS: 08-00-2b-0c-4a-8b
SCSI DEVICES:
Unit[7]
Unit[6]KN01--SII
Unit[5]
Unit[4]
Unit[3] Device type  0 DISK
          RMB                0x0
          Version            1
          Response data format 1 CCS
          Additional length   31
          Vendor              DEC
          Product identification RZ23      (C) DEC
          Firmware revision level 0618
Unit[2]
Unit[1]
Unit[0]
```

**Figure 3-1. Sample configuration display**

From this display, you learn the following:

**Line 1** — Tells you how much memory you have in your system. The system described in the figure has 16 megabytes of memory. You could add one or two 4-megabyte memory modules to this system.

**Line 2** — Tells you what kind of monitor you have. The system described in the figure uses a monochrome monitor. If it had a color monitor, this line would read `COLOR`.

**Line 3** — Tells you your Ethernet station address. The address for the system described in the figure is `08-00-2b-0c-4a-8b`. You need to know your Ethernet address if you want to be able to connect your workstation to a network.

**Line 4** — Introduces the list of small computer system interface (SCSI) device locations available in your system. The remaining lines of this display describe any SCSI devices assigned to units 7 through 0.

**Line 5** — Tells you that the system described in the figure has nothing assigned to unit 7. Leave this unit empty. Assigning a storage device to unit 7 can cause the system to malfunction.

**Line 6** — Tells you that unit 6 contains the controller that directs the operation of your SCSI devices.

**Lines 7, 8** — Tell you that the system described in the figure has nothing assigned to units 5 and 4. You could add storage devices here.

**Line 9** — The system in the figure has a hard disk drive assigned to unit 3. The words `Device type 0 DISK` appear on the unit-number line for any unit that contains a hard disk. If unit 3 contained a tape drive, the words `Device type 1 TAPE` would appear on the unit-number line. If unit 3 contained an optical compact disc drive, the words `Device type ROM DISK` would appear on the unit number line.

**Lines 10-16** — Describe the device assigned to unit 3 in more detail. This type of description is displayed for any SCSI device connected to your system.

**Lines 17, 18, 19** — The system described in the figure has no devices assigned to units 2, 1, and 0. You could add storage devices here.

## Using Console Commands

By typing commands, called console commands, at the console prompt (>>), you can gather some important information about your workstation hardware.

Many of the console commands are used for diagnostic testing and debugging by Digital service personnel. However, you may find the commands described here useful to know.

***Important:** All commands typed at the console level are case sensitive. The workstation does not recognize uppercase and lowercase letters as the same input.*

help	Displays the list of console commands and tells how to issue them.
?	Displays the list of console commands and tells how to issue them.
init	Performs a full initialization of your system.
printenv	Displays the environment variables. This display contains a list of variables, such as the baud rate for your communications devices, and gives the current value for each variable.
test -a	Runs the workstation's hardware self-test.
test -c	Runs the configuration test and displays your current configuration.

For a more extensive list of console commands, see Appendix C of this guide.

### Booting the Worksystem Software

When you boot your worksystem software, you load your software onto your system so that you can work with your system. When you boot successfully, your workstation prompts you for your username.

- To boot from the console program to a normal time-sharing environment, enter **auto** at the console prompt (>>).

- To boot from the console program to single-user mode, enter **boot** at the console prompt (>>).
- To boot from the console program to single-user mode using software on a network server, enter **boot -f mop()** at the console prompt (>>).

Booting a standalone workstation from disk takes approximately 3 minutes. If you boot the operating system successfully, the workstation prompts you to log on.

If the workstation does not boot successfully, contact your system manager.

### **Setting the Workstation for Automatic Booting**

To set the workstation for automatic booting, use the `setenv` console command. Enter **setenv bootmode a** at the console prompt (>>).

The workstation automatically boots, using the file designated in the `bootpath` variable, each time power is turned on.

For a discussion of the `setenv` command, see Appendix C of this guide.

If the workstation does not boot successfully, contact your system manager.

## Shutting Down the Worksystem Software

When you want to shut down the worksystem software, contact your system manager or consult the documentation that came with your worksystem software. The commands you use to shut down your worksystem software are described in Table 3-1.

**Table 3-1. Shutdown Commands**

Command	Result
<code>/etc/shutdown -h now</code>	Starts the operating system shutdown procedure immediately, without issuing warning messages.
<code>/etc/shutdown -h HHMM</code>	Shuts down the operating system at a specified time. In this table, HH indicates hours and MM indicates minutes. The workstation sends warning messages to all users on the local area network (LAN) indicating shutdown time.
<code>/etc/shutdown -h +N</code>	Shuts down the operating system after a specified number of minutes. In this table, N indicates the number of minutes after which the operating system shuts down. The workstation sends warning messages to all users on the LAN at an increasing frequency as shutdown time approaches.

---

## Using the Tape Drive

This chapter tells you how to use an external tape drive.

The optional TK50Z tape drive can store 95 million characters, called bytes, on each of its tape cartridges. Its function is to read and write data to and from the magnetic tape in a cartridge.

The cartridges for your tape drive contain magnetic tape on a single reel. The top of each cartridge carries the label "CompacTape."

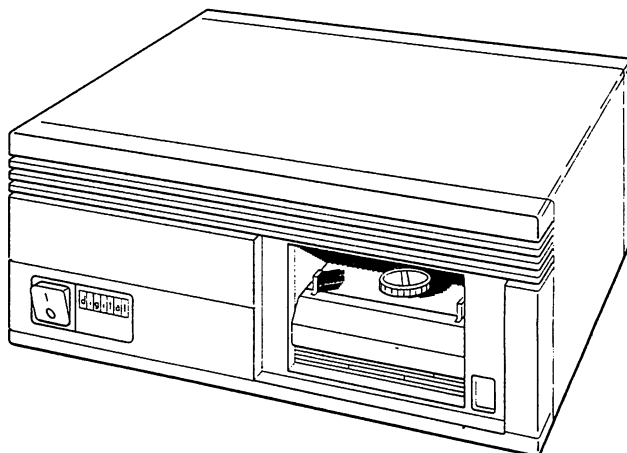

DEPG034

**Figure 4-1.** The tape drive

## Checking the Position of the Tape Leader Inside a Cartridge

The magnetic tape inside a cartridge begins with a plastic leader. When the cartridge is inserted into a tape drive, a take-up leader inside the drive mates with the leader on the tape. This take-up leader draws the tape out of the cartridge and onto the take-up reel inside the tape drive.

Before using a cartridge, check the position of the leader inside it to make sure it is correct.

1. Remove the cartridge from its protective case.
2. Open the door on the back of the cartridge.
  - a. Insert your thumb into the groove on the right corner of the back of the cartridge.
  - b. Press up on the door lock to release it.
  - c. Push the right edge of the door away from you until the door is fully open and you can see the leader.

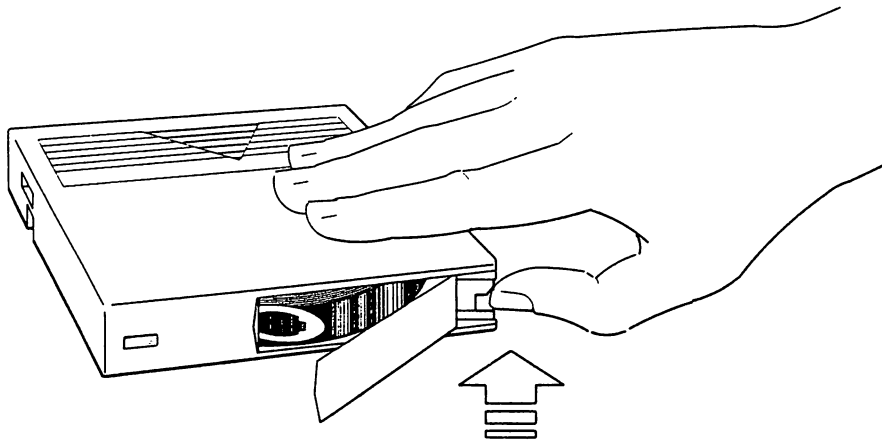

DEPG009

Figure 4-2. Opening the door on the cartridge

3. Be sure the leader is positioned as shown in Figure 4-3. If it looks different in any way, use another cartridge.

**Caution:** *Using a cartridge that has an incorrectly positioned leader can damage your tape drive.*

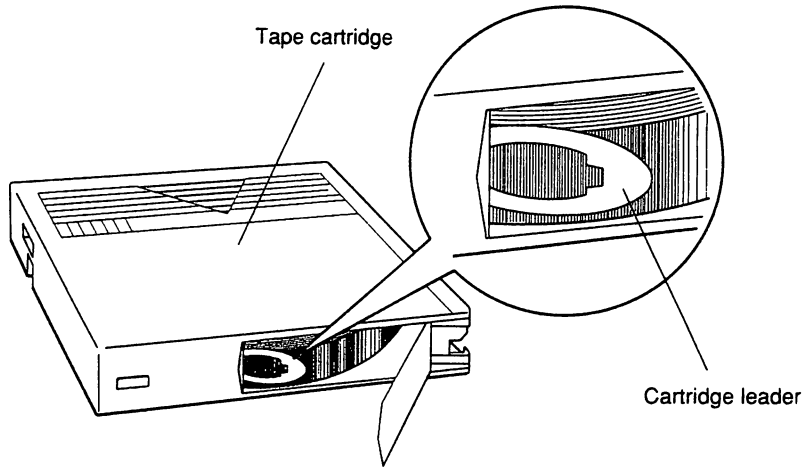

DEPG010

Figure 4-3. A tape leader positioned correctly in the cartridge

## Write-Protecting a Cartridge

To prevent information on the tape from being written over, write-protect the cartridge. Do this when you use your drive to read software or data from the tape.

To write-protect a cartridge,

1. Find the write-protect switch on the right side of the front of the cartridge.
2. Slide the switch to the left until an orange dot appears above the left arrow on the switch.

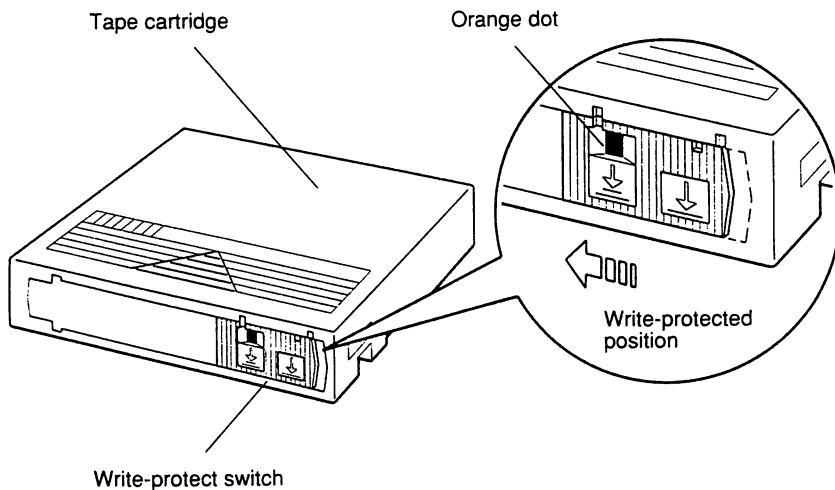

DEPG011

Figure 4-4. A write-protected cartridge

## Write-Enabling a Cartridge

When you want to write data to a cartridge, write-enable it. Do this when you want to use your drive as a backup device.

To write-enable a cartridge,

1. Find the write-protect switch on the right side of the front of the cartridge.
2. Slide the switch all the way to the right until the orange dot disappears.

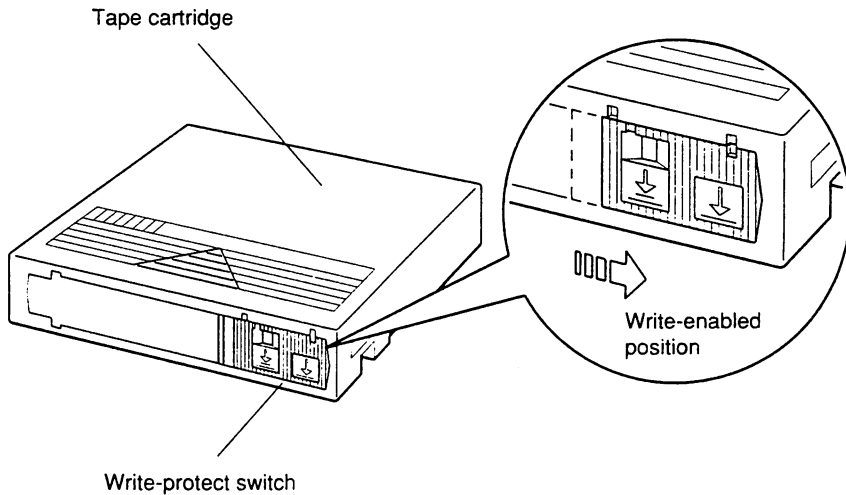

DEPG012

**Figure 4-5. A write-enabled cartridge**

## Checking the Take-Up Leader Inside the Drive

The take-up leader inside the drive must be in the correct position for it to mate with the tape cartridge leader.

**Caution:** *Trying to use a tape drive when the take-up leader is not in the correct position can damage the drive.*

1. Find the cartridge insert/release handle on the front of the expansion box.
2. Press the handle down until you can see the leader inside the drive.
3. Be sure the leader is positioned as shown in Figure 4-3.

If the leader is not positioned correctly, call your Digital service representative.

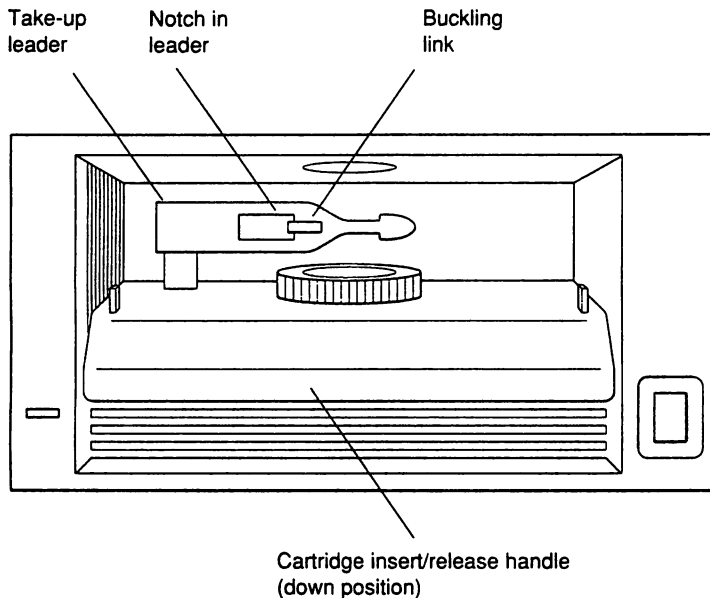

DEPG013

**Figure 4-6.** A take-up leader positioned correctly in the drive

## Loading a Tape Cartridge

When you load a cartridge, the tape automatically threads onto the reel inside the drive.

1. Press and release the load/unload button on the front of the expansion box until it pops into the unload (out) position.

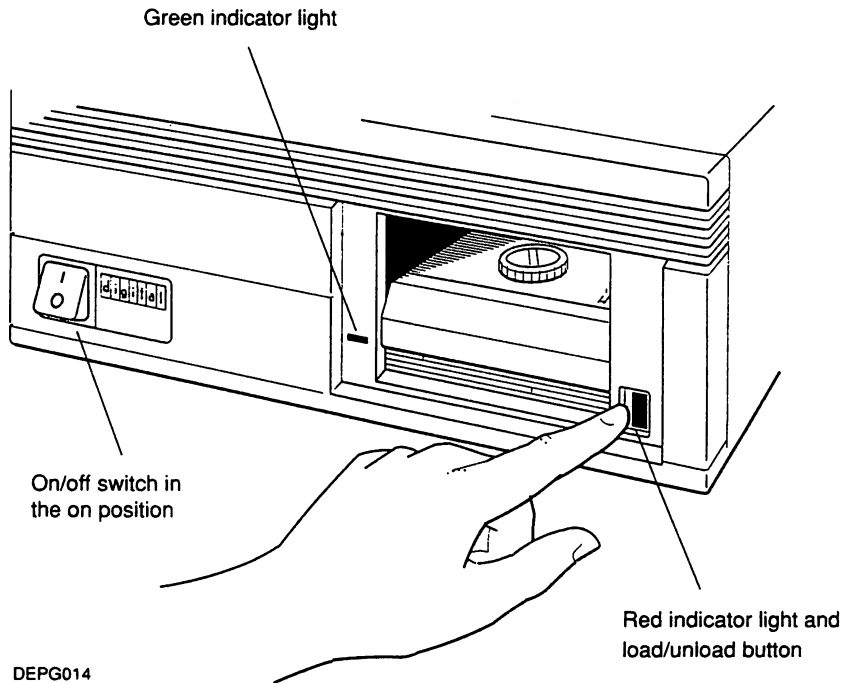

**Figure 4-7. Pressing the load/unload button on a tape drive**

2. Turn on the drive by pressing the 1 on the on/off switch on the front of the drive.

The red light in the lower-right corner of the front of the box glows for 5 to 15 seconds while the drive runs its self-test.

If the self-test fails, or if there is any problem with the drive, the red light blinks rapidly.

If this occurs, stop using the drive and refer to Chapter 6 of this guide for troubleshooting procedures or call your system manager or Digital service representative for help.

3. When the red light goes out and the green light in the lower-left corner glows, lift the cartridge insert/release handle to open the drive door.

**Caution:** *Lifting the insert/release handle while the red light glows or blinks can damage the tape and the drive.*

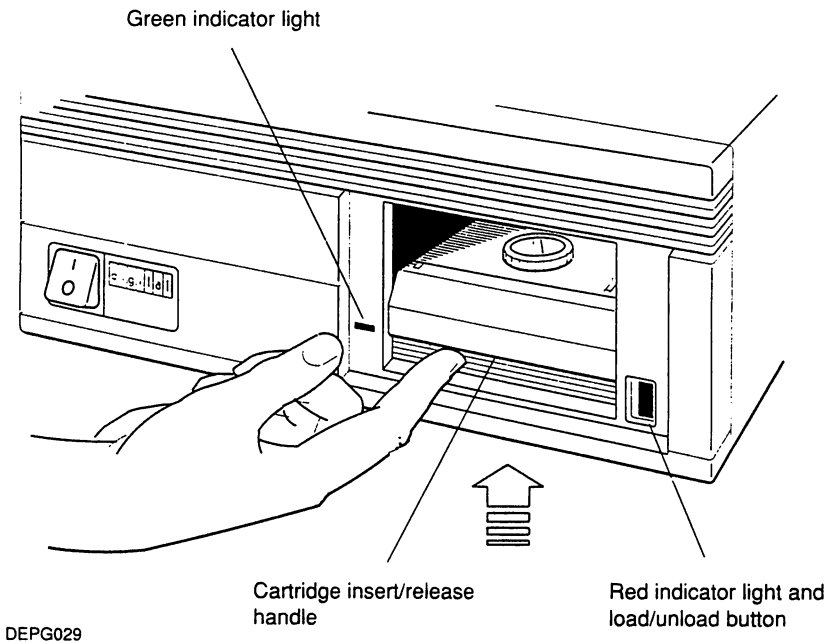

DEPG029

**Figure 4-8.** Lifting the insert/release handle on a tape drive

4. Position the cartridge so the arrow is on top and pointing away from you and the write-protect switch faces you.
5. Place the cartridge part way into the drive.

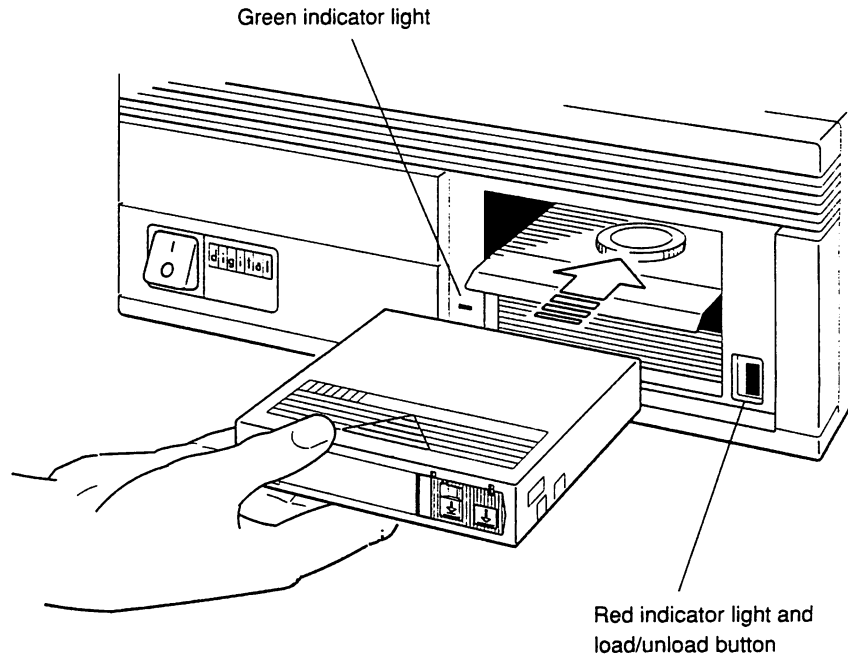

DEPG026

**Figure 4-9. Inserting a tape drive**

6. When you begin to feel resistance, push the cartridge firmly and smoothly into the drive until it locks into place.  
The green light turns off and the red light glows.

7. Lower the insert/release handle to close the drive door, as shown in Figure 4-10.
8. Wait for the red light to turn off and the green light to glow.
9. Press the load/unload button until it locks into the load (in) position.

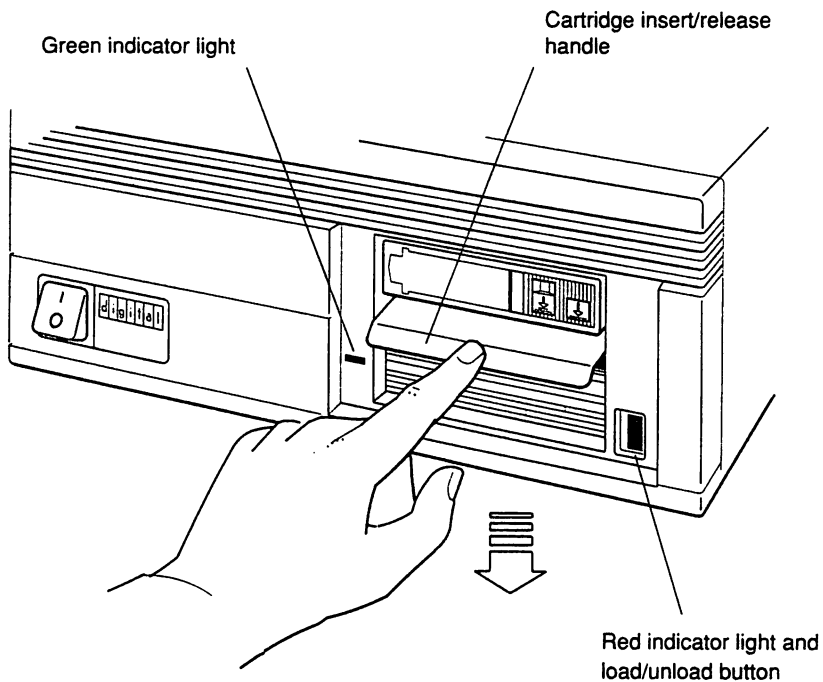

DEPG028

**Figure 4-10. Lowering the insert/release handle on a tape drive**

10. Begin to use the cartridge when the red and green lights both glow steadily.

As you use the cartridge, you will notice the following:

- The green light blinks while the red light glows during normal system operation.
- Both the red and green lights blink while the tape rewinds.
- The green light turns off and the red light blinks rapidly when a problem occurs.

If this happens, see Chapter 6 of this guide for troubleshooting procedures or call your system manager or Digital service representative for help.

## Removing a Tape Cartridge

Before you remove a cartridge, the tape must be fully rewound. This process can take up to 90 seconds. Rewinding occurs automatically when you attempt to remove the cartridge.

1. Press and release the load/unload button on the front of the expansion box until it pops out into the unload position.

If any tape must be rewound, the red and green lights blink slowly while rewinding is in process.

2. Wait 8 to 10 seconds for the tape to unload after rewinding is complete.

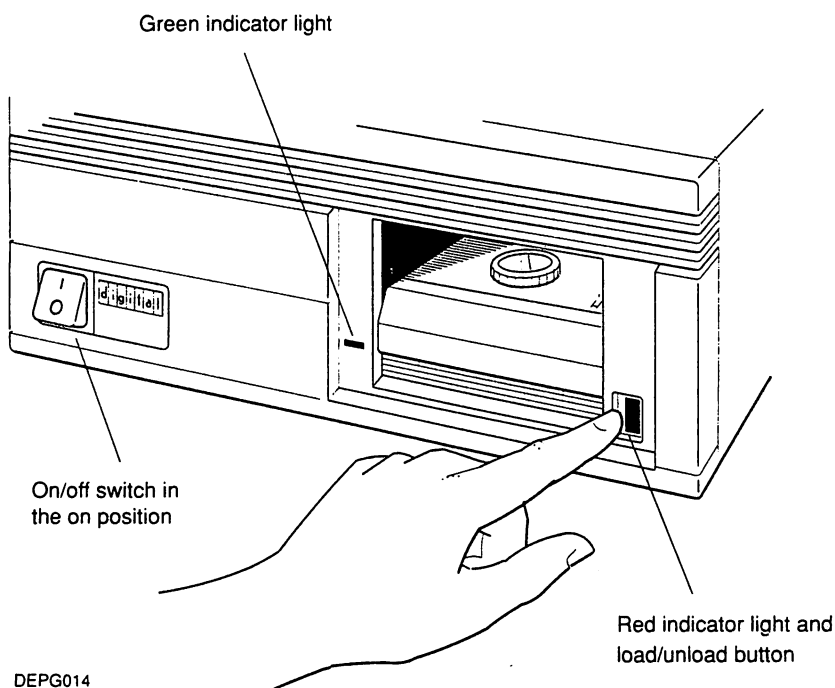
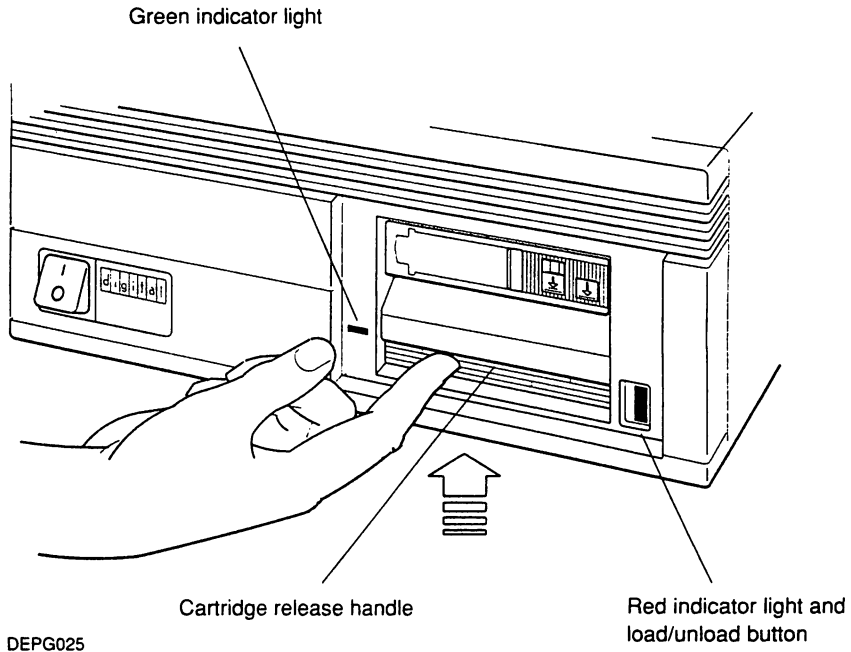

Figure 4-11. Pressing the load/unload button on a tape drive

- The red light glows steadily while the tape unloads.
  - When the red light turns off and the green light glows, you can remove the cartridge.
3. Lift the insert/release handle on the front of the expansion box to partially eject the tape.

**Caution:** *Lifting the insert/release handle while the red light glows or blinks can damage the tape and drive.*



**Figure 4-12.** Lifting the insert/release handle on a tape drive

4. Pull the cartridge out of the drive, as shown in Figure 4-13, and return it to its protective case.
5. Press the 0 on the on/off switch to turn off the drive.

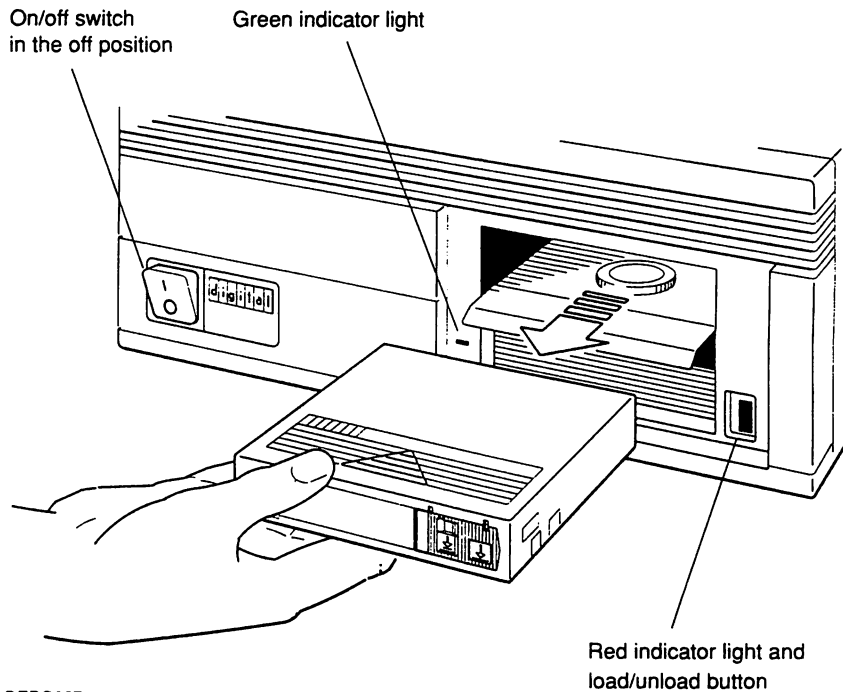

DEPG027

**Figure 4-13. Removing a tape cartridge**

## Labeling a Tape Cartridge

Give your cartridge a name that clearly states what information is on the tape.

1. Write the name you've selected on the label that came with your cartridge.
2. Slide the label into the slot on the front of the cartridge.

**Caution:** Putting a label anywhere other than on the front of the cartridge can damage the tape drive.

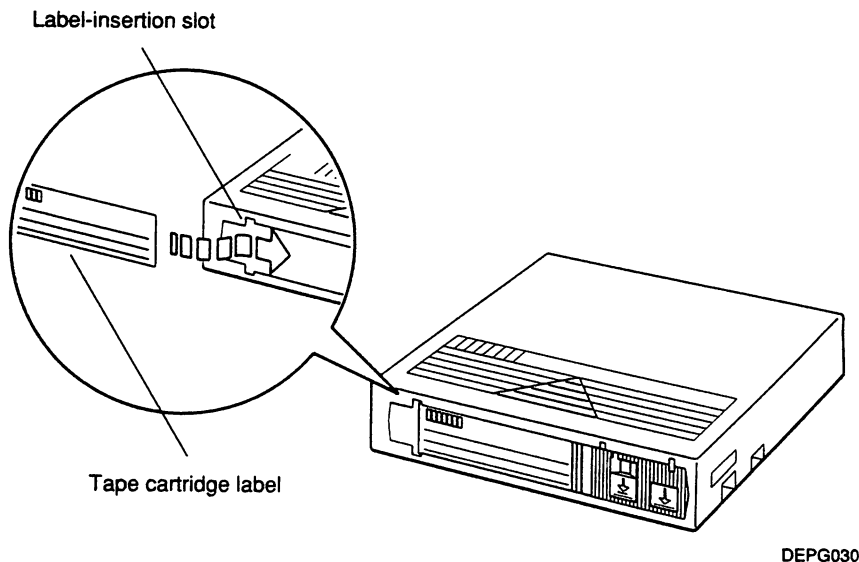

DEPG030

Figure 4-14. Labeling a tape cartridge

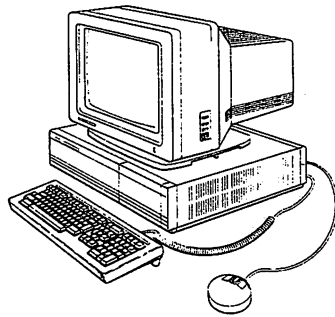

---

## Using the Optical Compact Disc Drive

This chapter tells you how to use an optical compact disc drive.

The disc drive is a read-only storage device that reads data from removable compact discs. Its uses include reading instructions during software installation and storing database data and online documentation.

The RRD40 optical compact disc drive, which can store up to 635 megabytes of data, comes preinstalled in an expansion box designed to sit on a desk or table.

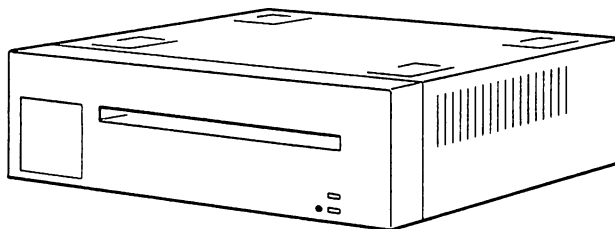

DEFO011

Figure 5-1. The optical compact disc drive

## Connectors, Controls, and Indicator Lights on the Disc Drive

The optical compact disc drive has the controls, indicators, and connectors pictured in Figure 5-2 and described in Table 5-1.

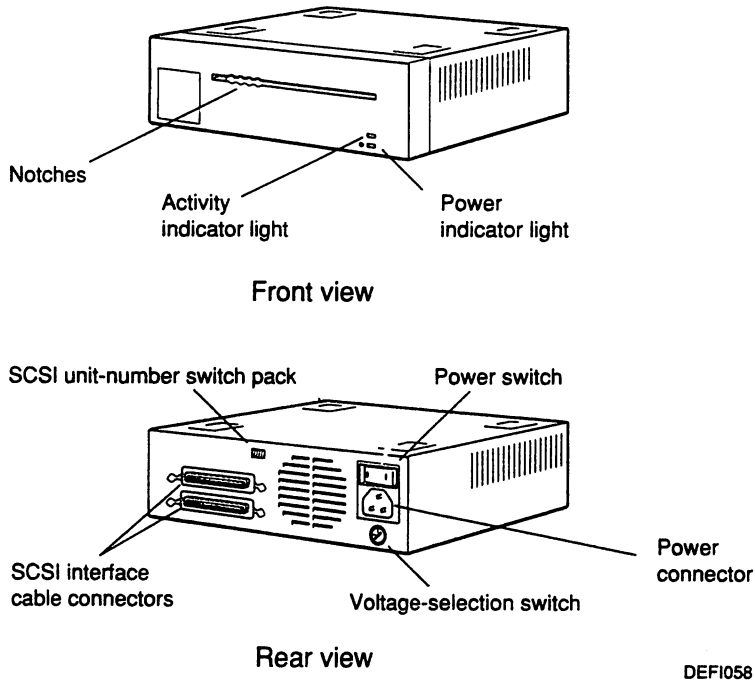

Figure 5-2. Connectors, controls, and indicator lights on the drive

**Table 5-1. Connectors, Controls, and Indicator Lights on the Disc Drive**

<b>Item</b>	<b>Function</b>
Power indicator light	Glows green to indicate the drive is receiving power.
Activity indicator light	Glows green to indicate a disc has been loaded into the drive; blinks while the disc transfers information.
Top cable connector	The point at which the disc drive connects to the system unit.
Bottom connector	Contains the small computer systems interface (SCSI) terminator that was removed from the system unit SCSI connector when the drive was connected to it.
SCSI switches	Allow you to set the SCSI address on your optical compact disc drive.
On/off switch	Turns the drive on and off. Pressing the 1 turns the drive on. Pressing the 0 turns it off.
Voltage-selection switch	Lets you match the drive's voltage to the voltage available at the power source.

## Using an Optical Compact Disc Drive

An optical compact disc is one part of a three-part caddy that consists of the following:

- The disc
- A plastic frame that curves around the sides of the disc
- A transparent protective sleeve that covers the disc and frame

When the caddy is not in a drive, the frame surrounds the disc and is locked into place by a tab in each of the two corners of the frame. When you insert the caddy into a drive, the tabs unlock and the frame releases the disc. You then remove the sleeve from the drive.

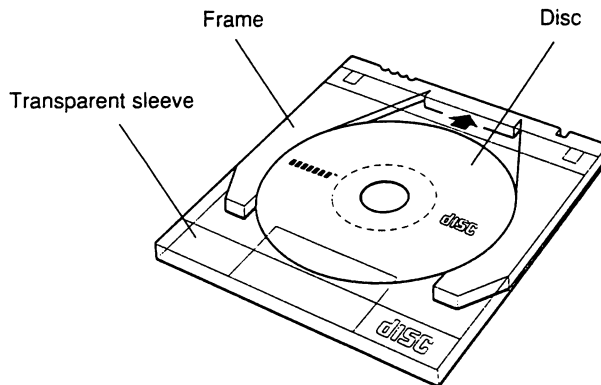

DEFO029

Figure 5-3. The parts of a disc caddy

## To Load a Disc into a Drive

1. Look at the caddy carefully to be sure it is not damaged in any way.

*Caution: Loading a cracked or otherwise damaged caddy into the drive can damage the disc and the drive.*

2. Turn on the drive by pressing the 1 on the on/off switch on the back of the drive, as shown in Figure 5-4.
3. Be sure the power light in the lower-right corner of the front of the drive is glowing green.

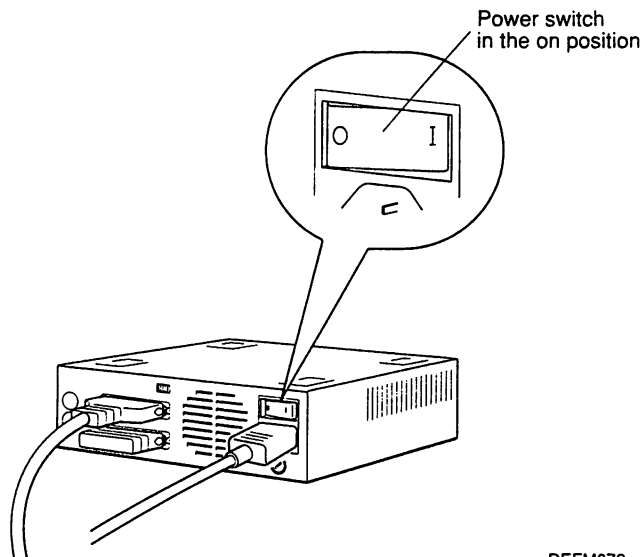

DEFM072

Figure 5-4. Turning on the drive

4. Position the caddy so that
  - The hooked sides of the locking tabs face down
  - The locking tabs face the door of the drive
  - The label on the disc faces up
  - The notches on the caddy are on the left and line up with the notches on the door of the drive

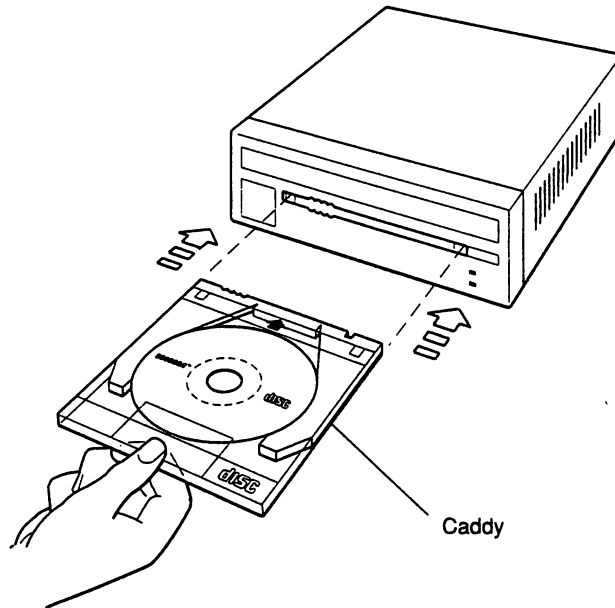

DEFO030

**Figure 5-5. Positioning the caddy**

If any of these conditions cannot be met, the disc is positioned incorrectly in the caddy. Use another disc or refer to the discussions of unloading discs from and loading discs into caddies later in this chapter.

*Caution: Using a disc positioned incorrectly in its caddy can damage the disc.*

5. Insert the caddy straight into the drive, sliding it in as far as it will go.

*Caution: Inserting a caddy at an angle can damage the drive.*

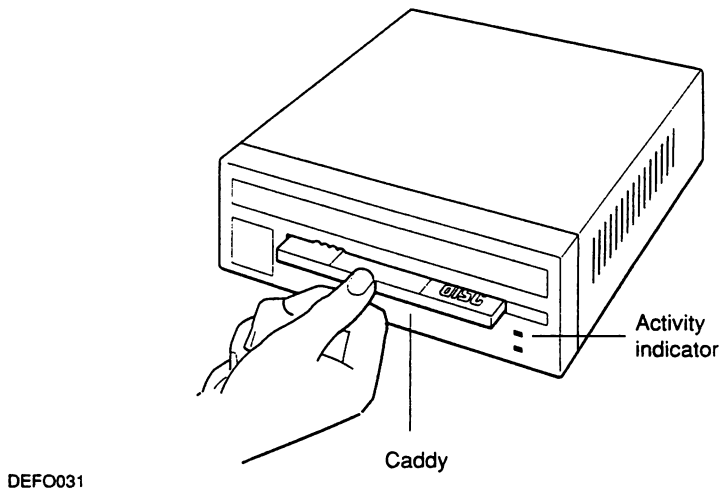

**Figure 5-6. Inserting the caddy**

6. Pull the protective sleeve out of the drive. The frame and the disc remain inside the drive.

Within 5 seconds, the green activity light begins to glow. If the light fails to glow, unload the disc, check to make sure it is positioned correctly, and insert it into the drive again.

If the activity light still fails to glow, contact your Digital service representative.

## To Unload a Disc from a Drive

1. Be sure the green activity light glows steadily before you unload the disc. If the light blinks, the drive is transferring data. Wait until the blinking stops.
2. Position the protective sleeve so that
  - The open portion of the sleeve faces the drive door
  - The arrow on the sleeve faces up and points toward the drive door

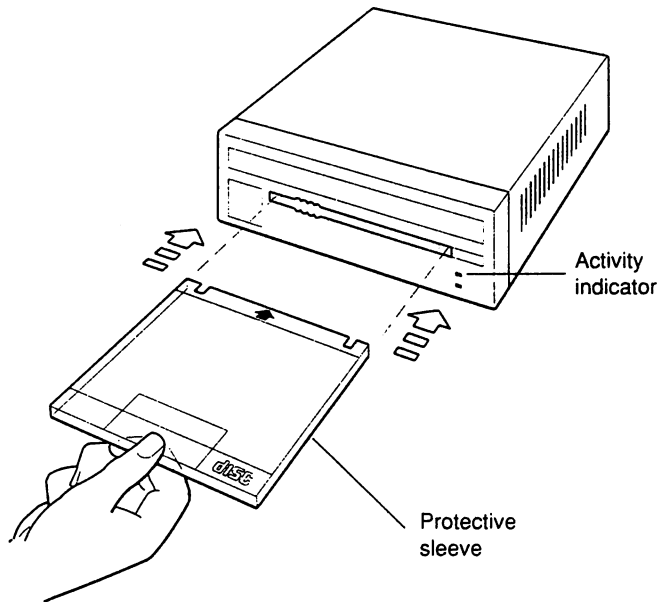

DEFO032

Figure 5-7. Positioning the protective sleeve

3. Insert the sleeve into the drive as far as it will go.  
**Caution:** *Inserting the sleeve at an angle can damage the drive and the disc.*
4. Pull the caddy straight out of the drive. The disc and frame come out in the sleeve, and the green activity light goes out.

## Handling Compact Discs

When handling a disc that is not in its caddy, work over a flat surface and position the disc with its label side down. This reduces the chances of damaging the data surface if you drop the disc.

Be careful not to touch the data side of the disc (the side without the label on it).

**Caution:** *Touching the data side of the disc when it is out of the caddy can cause tracking errors.*

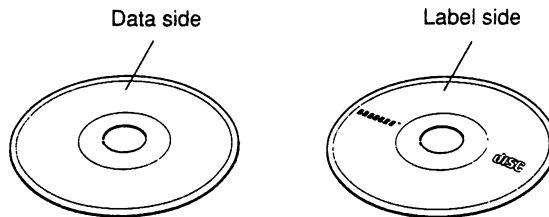

DEFO033

Figure 5-8. A compact disc

## To Unload a Disc from Its Caddy

1. Position the caddy so the hooked sides of the frame-locking tabs face up.
2. Use the tip of a ballpoint pen, or some similar instrument, to press down on each tab while gently pulling the frame away from the sleeve.
3. Pull the frame a little way out of the sleeve.

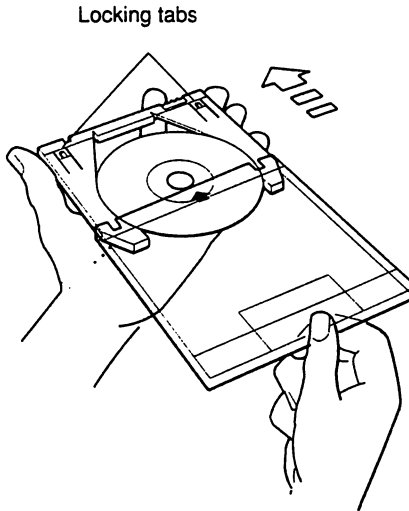

DEFO046

Figure 5-9. Beginning to remove the frame

4. Keeping continuous light pressure on the sides of the frame so it holds the disc firmly in place, completely remove the frame and disc from the sleeve. The disc is not locked in the frame; it is only the pressure of your hand that keeps it there.

**Caution:** *Releasing pressure on the sides of the frame allows the disc to drop out of the frame and can cause tracking errors.*

5. Place the index finger of your free hand in the hole in the disc and rest your thumb against the outer edge of the disc.

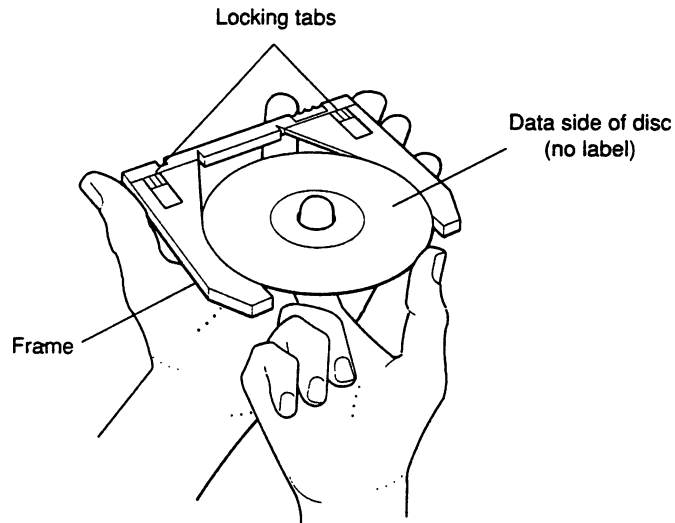

DEFO034

**Figure 5-10. Holding the disc**

6. Release the pressure you've been keeping on the frame and remove the disc from inside the frame.

## To Load a Disc into Its Caddy

1. Hold the disc with the index finger of one hand in the hole in the disc and the thumb of that hand resting against the side of the disc.
2. Position the disc so the data (unlabeled) side of the disc faces up.

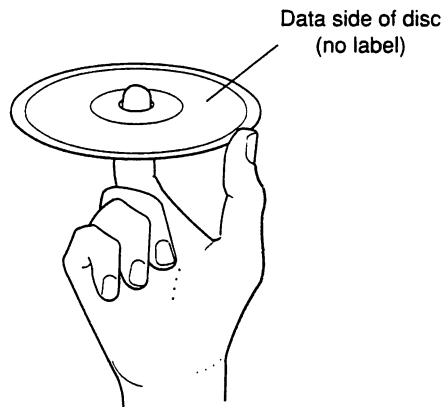

DEFO035

Figure 5-11. Positioning the disc

3. With the other hand, position the frame so the hooked sides of the locking tabs face up.

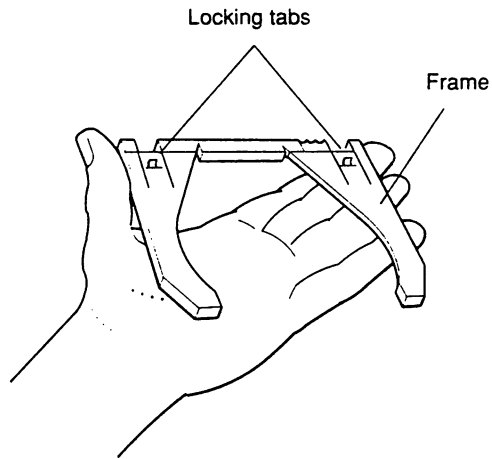

DEFO037

**Figure 5-12. Positioning the frame**

4. Place the disc inside the frame and press the sides of the frame firmly against the disc.

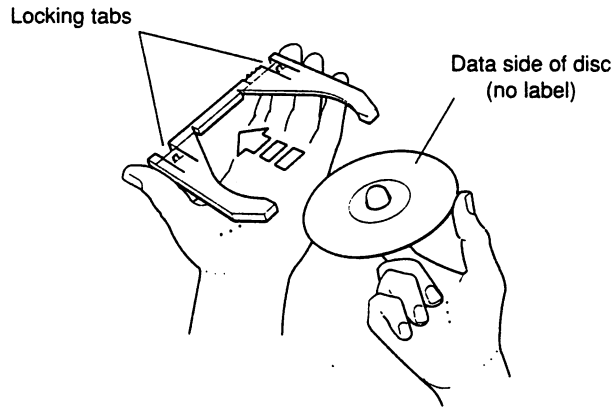

DEFO038

**Figure 5-13. Placing the disc inside the frame**

5. Insert the disc and frame into the sleeve until the locking tabs snap into place.

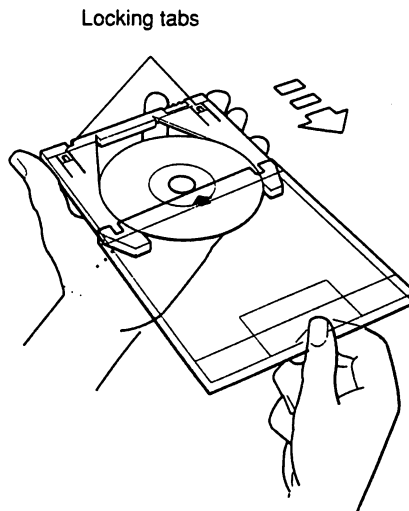

DEFO039

**Figure 5-14. Inserting the disc and frame into the sleeve**

## Cleaning a Compact Disc

Tracking errors can develop when discs become dirty.

To clean a disc,

1. Remove the disc from its caddy, as described earlier in this chapter.
2. Hold the disc by its edges, with one finger in the hole in the center of the disc and your thumb resting against the side of the disc.
3. Use a dry, lint-free cloth to wipe the disc with small circular strokes, moving from the center of the disc out toward the rim.

*Caution:* Using a continuous circular stroke around the disc can damage the disc.

## For Further Information

For a more detailed discussion of the RRD40 optical compact disc drive, see the *RRD40 Optical Disc Drive Owner's Manual*, which came with your drive.

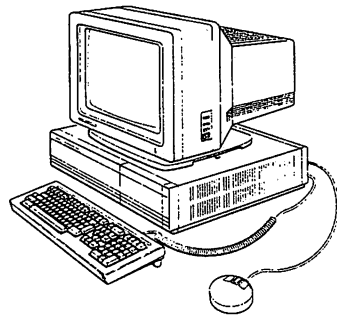

---

## Troubleshooting

This chapter tells you

- How to use the DECstation 2100/3100 self-test
- What you can do to correct hardware problems
- When you need to ask for help
- What kind of information your Digital service representative needs from you

## Using the Self-Test

The self-test consists of a number of subtests that check the parts of your workstation and tell you whether they are working correctly.

You can run the self-test in one of the following ways:

- By turning on your system unit
- By pressing the reset button on the back of the system unit
- By typing **test -a** at the console prompt (>>) and pressing Return

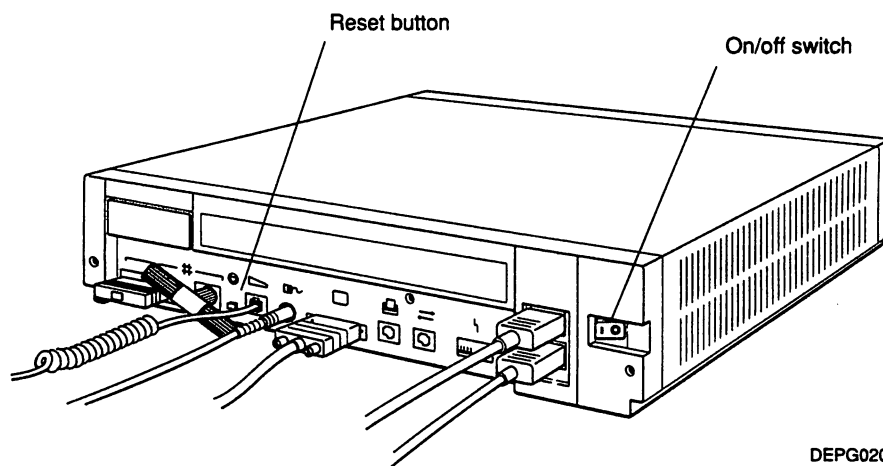

DEPG020

**Figure 6-1.** The on/off switch and reset button on the system unit

When you turn on the system unit or press the reset button, the self-test starts automatically.

If this power-up self-test is successful, a display similar to the following appears on your screen:

```
KN01 V6.71
7..6..5..4..3..2..1..0
16Mb.....0
KN01 V6.71
08-00-2b-0d-f7-6a
0x01000000
>>
```

When you type **test -a** to run the self-test, the power to the workstation is not turned off.

If this self-test is successful, a display similar to the following appears on your screen:

```
KN01 V6.71
7..6..5..4..3..2..1..0
16Mb.....0
>>
```

## If a Subtest Fails

If your workstation fails one of the subtests, self-testing stops and a display similar to the following appears on the screen:

```
KN01 V6.71
7..6..5..4..3..2..
FAILURE
16Mb.....0
>>
```

The number of the subtest that failed is the last number that appears on your screen before the failure message. In the preceding example, subtest 2 failed.

## If Subtest 7, 6, 5, or 4 Fails

Record the number of the subtest that failed and report it to your system manager or your Digital service representative.

## If Subtest 3 Fails

Check your mouse and keyboard. Turn off your system unit before performing each of the following steps. Turn it back on to rerun the self-test.

**Caution:** *Checking a connection or connecting a new device with the system unit turned on can damage the system unit and the device.*

- Make sure the mouse and keyboard cable connectors are securely seated in their connectors on the back of the system unit.
- Try another mouse.
- Try another keyboard.

If the subtest still fails, report its number to your system manager or your Digital service representative.

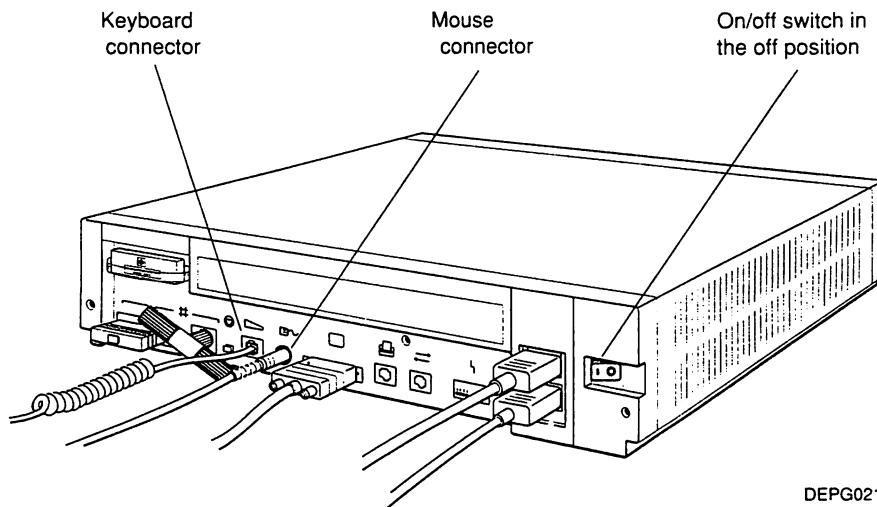

Figure 6-2. Checking the mouse and keyboard connections

## If Subtest 2 Fails

Check your Ethernet connections.

**Caution:** *Checking a connection or connecting a cable to the system unit while the unit is turned on can damage the system unit.*

### For a workstation not on a network

1. Make sure a ThickWire loopback connector is securely attached to the ThickWire connector on the back of the system unit (see Figure 6-3).

The light on the back of the loopback connector should glow green.

2. Turn off your system unit and make sure a ThinWire T-connector with a terminator on each end is securely attached to the ThinWire connector on the back of the system unit.
3. Turn on the system unit to rerun the self-test.
4. If your workstation continues to fail subtest 2, report the number of the subtest to your system manager or your Digital service representative.

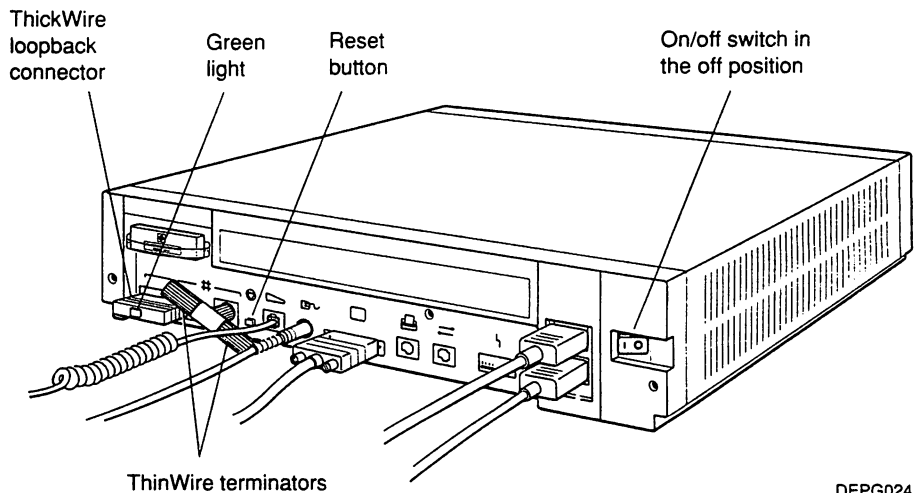

Figure 6-3. Checking Ethernet connections

### For a workstation on ThickWire Ethernet

1. Turn off your system unit and make sure the ThickWire cable connector is securely attached to the ThickWire connector on the back of the system unit and that the slide latch is engaged.
2. Turn on the system unit to rerun the self-test.
3. Check the Ethernet indicator light that lies between the ThickWire connector and the Ethernet button.
  - a. If the light is not glowing green, use the point of a ballpoint pen or some similar tool (but not a pencil) to press the Ethernet button.

*Caution: The graphite in pencil lead can damage the system unit.*

- b. Press the reset button to rerun the self-test.

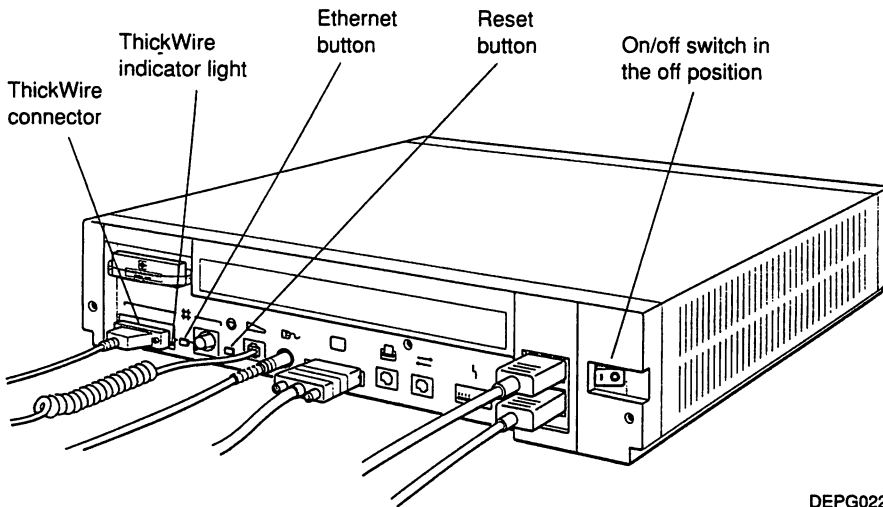

DEPG022

Figure 6-4. Checking ThickWire connections

4. If the light still fails to glow green, or if your workstation continues to fail subtest 2, report the number of the subtest to your system manager or your Digital service representative.

## For a workstation on ThinWire Ethernet

1. Turn off your system unit and make sure the ThinWire T-connector is securely connected to the ThinWire Ethernet connector on the back of the system unit (see Figure 6-5).
  - If your workstation is at the end of a ThinWire segment, make sure the ThinWire cable connector is firmly attached to one end of the T-connector and a ThinWire terminator is firmly attached to the other end.
  - If your workstation is within a ThinWire segment, make sure the ThinWire cable connectors are firmly attached to both ends of the T-connector.
2. Turn on the system unit to rerun the self-test.
3. Check the Ethernet indicator light that lies between the ThinWire connector and the Ethernet button.
  - a. If the light is not glowing green, use the point of a ballpoint pen or some similar tool (but not a pencil) to press the Ethernet button.

**Caution:** *The graphite in pencil lead can damage the system unit.*

- b. Press the reset button to rerun the self-test.

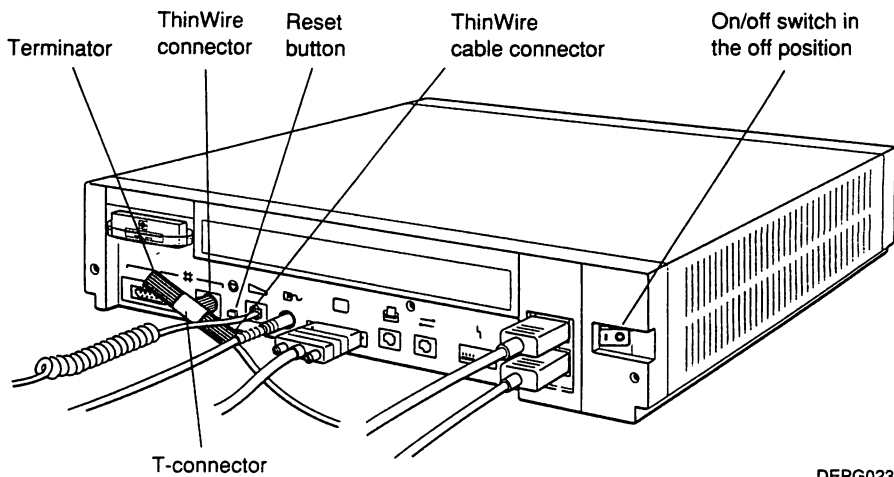

DEPG023

Figure 6-5. Checking ThinWire connections

4. If the light still fails to glow green, or if your workstation continues to fail subtest 2, report the number of the subtest to your system manager or your Digital service representative.

### If Subtest 1 Fails

Check your small computer system interface (SCSI) connections.

*Caution: Checking a connection or connecting a cable to the system unit while the unit is turned on can damage the system unit.*

#### For a workstation with no external storage devices

1. Turn off your system unit and make sure the SCSI terminator is securely connected to the SCSI connector on the back of the system unit.
2. Check the connectors on the terminator and system unit for damaged pins.
3. Turn on the system unit to rerun the self-test.

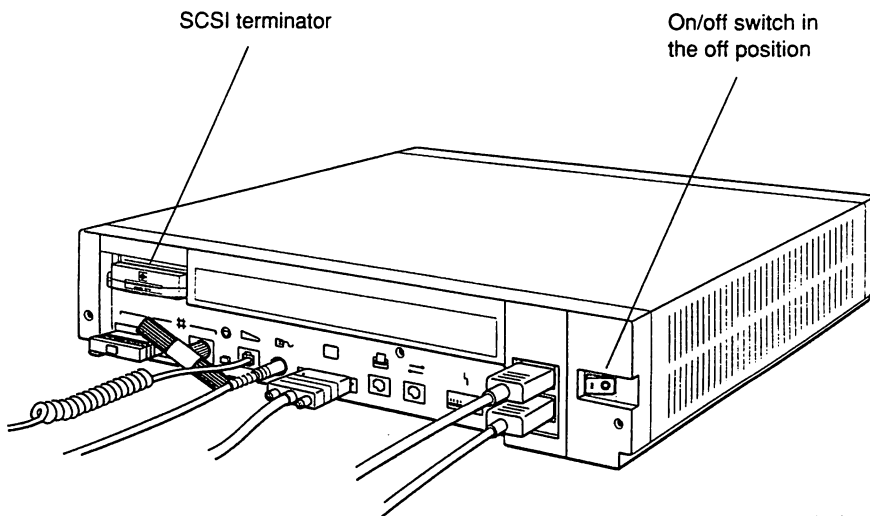

DEPG032

Figure 6-6. Checking the SCSI terminator

### For a workstation with external storage devices

1. Turn off your system unit and any external storage devices. If you have more than one such device, turn off your power strip.
2. Make sure that
  - All storage device cables are securely connected
  - The final device has a terminator securely seated in the unused connector
  - All connectors are free of damaged pins
  - The cable that runs between expansion boxes is the 18-inch cable supplied by Digital
3. Turn on any external storage devices and your system unit to run the self-test. If you have more than one external storage device connected to your workstation, turn on your power strip.
4. If subtest 1 continues to fail, report the number of the subtest to your system manager or your Digital service representative.

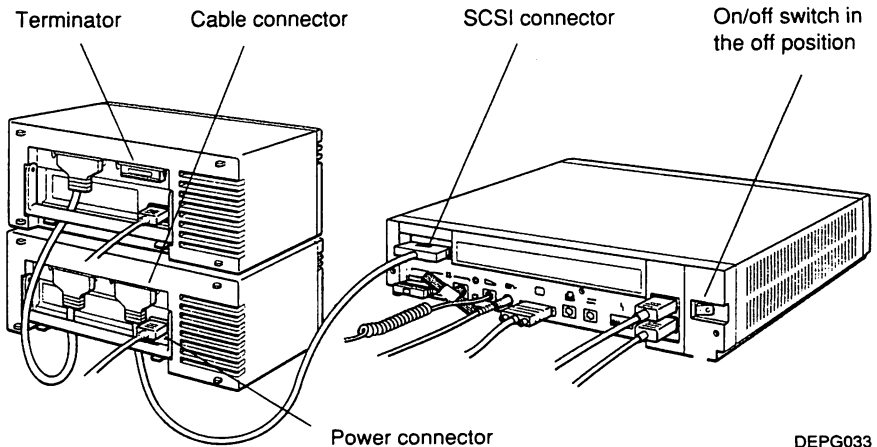

Figure 6-7. Checking SCSI connections

# Solving Hardware Problems

Table 6-1 offers solutions to some common hardware problems. If you follow the suggestions given here and your problem remains unresolved, contact your system manager or your Digital service representative.

**Table 6-1. Solutions to Common Hardware Problems**

<b>Problem</b>	<b>Solution</b>
The monitor screen is blank.	<p>Follow these steps:</p> <ol style="list-style-type: none"><li>1. Press any key on your keyboard. If your screen saver was active, the display will reappear.</li><li>2. Adjust your brightness and contrast controls to increase the brightness and contrast.</li><li>3. Be sure your system unit and monitor are turned on.</li><li>4. Turn off your system unit.</li><li>5. Be sure the monitor-system unit power cable and the system unit power cord are connected correctly.</li><li>6. Be sure the video cable is securely connected to the monitor and the system unit.</li><li>7. Turn on your system unit.</li></ol>
The screen display is distorted or unstable.	<p>Follow these steps:</p> <ol style="list-style-type: none"><li>1. Turn off your system unit.</li><li>2. Make sure the video cable connectors are correctly attached to the monitor and system unit.</li><li>3. Turn on the system unit.</li></ol>

(continued on next page)

**Table 6-1 (Cont.). Solutions to Common Hardware Problems**

<b>Problem</b>	<b>Solution</b>
Color is distorted or unclear.	Follow these steps: <ol style="list-style-type: none"><li>1. Move any electric pencil sharpener or other electromechanical devices away from the monitor.</li><li>2. Move such items as magnetic paper clip holders away from the monitor.</li><li>3. Press the degauss button on the monitor for 5 seconds.</li><li>4. If step 3 doesn't help, wait 10 minutes and press the degauss button for 5 seconds again.</li></ol>
On a color monitor, red or blue color is missing.	Follow these steps: <ol style="list-style-type: none"><li>1. Turn off the system unit.</li><li>2. Be sure the video cable connectors are correctly attached to the monitor and system unit.</li><li>3. Turn on the system unit.</li></ol>
Everything happening on your screen freezes.	<p><i>If you are on a network, follow these steps:</i></p> <ol style="list-style-type: none"><li>1. Wait a few minutes.</li><li>2. Press the reset button.</li></ol> <p><i>If you are not on a network, press the reset button.</i></p>

(continued on next page)

Table 6-1 (Cont.). Solutions to Common Hardware Problems

Problem	Solution
When you type, nothing happens on the screen.	<p>Follow these steps:</p> <ol style="list-style-type: none"><li data-bbox="485 263 1147 322">1. Press and release the Hold Screen key [F1] on your keyboard.</li><li data-bbox="485 343 881 367">2. Turn off your system unit.</li><li data-bbox="485 387 1170 479">3. Make sure the keyboard cable is firmly attached to the system unit and turn on the system unit again.</li><li data-bbox="485 500 1204 524">4. Turn off the system unit and try another keyboard.</li><li data-bbox="485 544 944 568">5. Turn on the system unit again.</li></ol>
You cannot log into the network.	<p><i>If you are using ThickWire Ethernet, follow these steps:</i></p> <ol style="list-style-type: none"><li data-bbox="485 667 1188 727">1. Be sure the ThickWire Ethernet indicator light to the right of the ThickWire connector glows green.  If it does not, use the point of a ballpoint pen or some similar tool (but not a pencil), to press and release the Ethernet button.  <b><i>Caution:</i></b> <i>The graphite in pencil lead can damage the system unit.</i></li><li data-bbox="485 970 881 994">2. Turn off your system unit.</li><li data-bbox="485 1014 1204 1106">3. Be sure your ThickWire connector is firmly attached to the ThickWire connector on the system unit.</li><li data-bbox="485 1127 881 1151">4. Turn on your system unit.</li></ol>

(continued on next page)

**Table 6-1 (Cont.). Solutions to Common Hardware Problems**

Problem	Solution
No cursor appears on the screen.	<i>If you are using ThinWire Ethernet, follow these steps:</i>
	<ol style="list-style-type: none"><li>1. Be sure the ThinWire Ethernet indicator light to the left of the ThinWire connector glows green.</li></ol>
	If it does not, use the point of a ballpoint pen or some similar tool (but not a pencil), to press and release the Ethernet button.
	<i>Caution: The graphite in pencil lead can damage the system unit.</i>
	<ol style="list-style-type: none"><li>2. Turn off your system unit.</li><li>3. Be sure your ThinWire cable connector(s) and/or terminators are firmly attached to the ThinWire T-connector.</li><li>4. Be sure the ThinWire T-connector is correctly attached to the ThinWire connector on the system unit.</li><li>5. Turn on your system unit.</li></ol>
	Follow these steps:
	<ol style="list-style-type: none"><li>1. Move the mouse around on your desktop to be sure you haven't accidentally moved the cursor off your screen.</li><li>2. Turn off your system unit.</li><li>3. Make sure the mouse cable is correctly connected to the system unit.</li><li>4. Turn on your system unit.</li><li>5. Turn off your system unit and try another mouse.</li></ol>

(continued on next page)

**Table 6-1 (Cont.). Solutions to Common Hardware Problems**

<b>Problem</b>	<b>Solution</b>
The cursor on the screen fails to follow the movement of the mouse on the desktop.	Follow these steps: <ol style="list-style-type: none"><li>1. Turn off your system unit.</li><li>2. Be sure the mouse cable is correctly connected to the system unit.</li><li>3. Turn on the system unit.</li><li>4. Turn off the system unit.</li><li>5. Disconnect the mouse and clean it as described in Chapter 1 of this guide.</li><li>6. Reconnect the mouse and turn on the system unit.</li><li>7. Turn off the system unit and try another mouse.</li></ol>
An error message appears when you try to use an external hard disk or tape drive.	<i>If you have only one external storage device, follow these steps:</i> <ol style="list-style-type: none"><li>1. Be sure the device is turned on.</li><li>2. Turn off the device and the system unit.</li><li>3. Be sure the system unit expansion cable is correctly connected to the device and the system unit.</li><li>4. Be sure a terminator is correctly attached to the second connector on the device.</li><li>5. Turn on the device and the system unit.</li></ol>

(continued on next page)

**Table 6-1 (Cont.). Solutions to Common Hardware Problems**

Problem	Solution
<p>A red light blinks rapidly on the front of your tape drive.</p>	<p><i>If you have more than one external storage device, follow these steps:</i></p>
	<ol style="list-style-type: none"><li>1. Be sure all devices and your system unit are receiving power from a common power strip.</li><li>2. Be sure all devices are turned on.</li><li>3. Turn off the power strip.</li><li>4. Be sure the system unit expansion cable is correctly connected to the first device and the system unit.</li><li>5. Be sure the connector cables between devices are the 18-inch cables supplied by Digital and that they are connected correctly.</li><li>6. Be sure a terminator is firmly attached to the second connector on the final device.</li><li>7. Turn on the power strip.</li></ol>
	<p>Follow these steps:</p>
	<ol style="list-style-type: none"><li>1. Push the load/unload button four times.</li><li>2. Turn the tape drive off and then back on again. Do this only one time.</li></ol>

(continued on next page)

**Table 6-1 (Cont.). Solutions to Common Hardware Problems**

<b>Problem</b>	<b>Solution</b>
An error message appears when you try to use your printer.	Follow these steps: <ol style="list-style-type: none"><li>1. Be sure your printer is turned on.</li><li>2. Turn off your printer and system unit.</li><li>3. Be sure your printer power cord is connected to an active power source.</li><li>4. Be sure the printer cable connector is correctly attached to the printer connector on the system unit.</li><li>5. Turn on your printer and system unit.</li><li>6. See the documentation that came with your printer for instructions on checking your printer's baud rate.</li></ol>
An error message appears when you try to use your communications device.	Follow these steps: <ol style="list-style-type: none"><li>1. Be sure your device is turned on.</li><li>2. Turn off your device and your system unit.</li><li>3. Be sure your device's power cord is connected to an active power source.</li><li>4. Be sure the connector on the communications device cable is correctly attached to the communications connector on the system unit.</li><li>5. Turn on your device and system unit.</li><li>6. See the documentation that came with your communications device for instructions on checking your device's baud rate.</li></ol>

## Contacting Your Digital Service Representative

If you have followed the suggestions offered in this chapter and your problem remains unresolved, your Digital service representative can help you. You can get your service representative's name and telephone number from your Digital sales representative.

Before you place your call,

- Write down the nature of the problem, including any error messages you have received and the number of any self-test that failed.
- List the steps you have taken to correct the problem and the results you got.
- Write down the serial and model numbers of your system and any peripheral device involved.
- Be prepared to type commands on the keyboard and read information from the screen as you talk to your service representative.

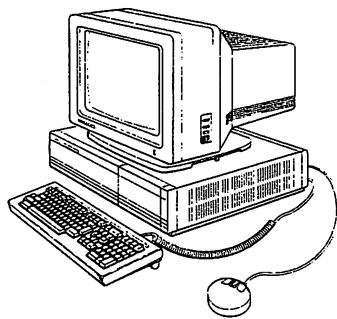

---

## Moving the DECstation 2100/3100 Workstation

This chapter tells you how to take your workstation apart and pack it in preparation for moving.

When you move your workstation, repack each piece of equipment in the carton it came in.

## Dismantling the Workstation

1. Follow the procedures for turning off your workstation given in Chapter 3 of this guide.
2. Unplug all power cords from the power source.
3. Disconnect any optional peripheral devices from the system unit, and if you have more than one expansion box, disconnect them from each other.
4. If you have a small computer system interface (SCSI) terminator in the SCSI connector on the back of the system unit, remove the terminator from that connector.
5. Replace the plastic cover that protected the SCSI connector when you first received the system unit.
  - a. Line up the top and sides of the cover with the top and sides of the opening around the SCSI connector.
  - b. Press up on the latch on the bottom of the cover until you can push it into the slot under the connector and the cover snaps into place.
6. Disconnect the monitor, mouse, and keyboard from the system unit.
7. If you are on a network, disconnect your Ethernet cable from the connector on the system unit.

**Caution:** *Disconnecting the Ethernet cable at the network instead of at the system unit interrupts network performance.*

## Packing Your Equipment

Pack each piece of equipment in the carton it came in.

Be sure to use the padding that came in the cartons to hold each item securely in place.

Be sure to include the following in each carton:

- Any cables, power cords, and terminators that came with that device
- The documentation for that device

## Reinstalling Your DECstation 2100/3100

To reinstall your workstation, follow the instructions in the *DECstation 2100/3100 Hardware Installation Guide*, which came in your DECstation 2100/3100 documentation kit.

**Table A-1. System Unit Description**

	Weight	Height	Width	Depth
System unit	17.8 kg (39 lb)	10.33 cm (4.07 in.)	46.38 cm (18.26 in.)	40.00 cm (15.75 in.)

**Table A-2. System Unit Operating Conditions**

Temperature range <sup>1</sup>	10° C to 40° C (50° F to 104° F)
Temperature change rate	11° C (20° F) per hour maximum
Relative humidity	10% to 90%, noncondensing
Altitude	2,400 m (8,000 ft) at 36° C
Maximum wet-bulb temperature	28° C (82° F)
Minimum dew-point temperature	2° C (36° F)

<sup>1</sup>Reduce maximum temperature by 1.8° C (3.24° F) for each 1,000-meter increase in altitude.

**Table A-3. System Specifications**

Input voltage	Auto adjust 100-120 Vac to 220-240 Vac
Input current	2.8 amps at 100 to 120 Vac 1.5 amps at 220 to 240 Vac
Power	190 watts
- Frequency	47 to 63 Hz
- Heat dissipation	155 watts maximum

**Table A-4. System Unit Nonoperating Conditions**

Temperature range	-40° C to 66° C (-40° F to 151° F)
Relative humidity	10% to 95% at 66° C (151° F)
Altitude	4,900 m (16,000 ft)
Maximum wet-bulb temperature	28° C (82° F)
Minimum dew-point temperature	2° C (36° F)

## Packing Your Equipment

Pack each piece of equipment in the carton it came in.

Be sure to use the padding that came in the cartons to hold each item securely in place.

Be sure to include the following in each carton:

- Any cables, power cords, and terminators that came with that device
- The documentation for that device

## Reinstalling Your DECstation 2100/3100

To reinstall your workstation, follow the instructions in the *DECstation 2100/3100 Hardware Installation Guide*, which came in your DECstation 2100/3100 documentation kit.

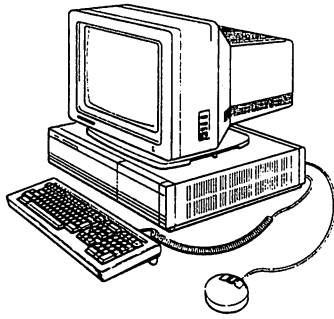

# A

---

## Equipment Specifications

This appendix lists the physical specifications, operating conditions, and nonoperating conditions for the following units:

- System unit
- VR150 monitor
- VR160 monitor
- VR262 monitor
- VR299 monitor
- LK201 keyboard
- VSXXX-AA mouse
- RZ55 hard disk
- TK50Z tape drive
- RRD40 optical compact disc drive
- RZ23 hard disk drive

**Table A-1. System Unit Description**

	<b>Weight</b>	<b>Height</b>	<b>Width</b>	<b>Depth</b>
System unit	17.8 kg (39 lb)	10.33 cm (4.07 in.)	46.38 cm (18.26 in.)	40.00 cm (15.75 in.)

**Table A-2. System Unit Operating Conditions**

Temperature range <sup>1</sup>	10° C to 40° C (50° F to 104° F)
Temperature change rate	11° C (20° F) per hour maximum
Relative humidity	10% to 90%, noncondensing
Altitude	2,400 m (8,000 ft) at 36° C
Maximum wet-bulb temperature	28° C (82° F)
Minimum dew-point temperature	2° C (36° F)

<sup>1</sup>Reduce maximum temperature by 1.8° C (3.24° F) for each 1,000-meter increase in altitude.

**Table A-3. System Specifications**

Input voltage	Auto adjust 100-120 Vac to 220-240 Vac
Input current	2.8 amps at 100 to 120 Vac 1.5 amps at 220 to 240 Vac
Power	190 watts
- Frequency	47 to 63 Hz
- Heat dissipation	155 watts maximum

**Table A-4. System Unit Nonoperating Conditions**

Temperature range	-40° C to 66° C (-40° F to 151° F)
Relative humidity	10% to 95% at 66° C (151° F)
Altitude	4,900 m (16,000 ft)
Maximum wet-bulb temperature	28° C (82° F)
Minimum dew-point temperature	2° C (36° F)

**Table A-5. VR150 Monitor Description**

	Weight	Height	Width	Depth
Monitor	16.34 kg (36 lb)	39.4 cm (15.5 in.)	36.9 cm (14.5 in.)	40.3 cm (15.9 in.)

**Table A-6. VR150 Monitor Specifications**

External controls and indicators	Brightness Contrast Power switch Power indicator
Tilt range	-5° to + 13°
Swivel range	± 60°
Display	
- Cathode-ray tube (CRT)	383 mm (15 in.) diagonal flat square Paper white phosphor High-efficiency antiglare treatment; reflects less than 1% of incident light within the visible spectrum
- Video input	75 ohms terminated BNC composite video
- Video composite signal (with sync)	1.0 Vpp/75 ohm
- Display characteristics	1,024 pixels horizontal x 864 lines vertical, giving approximate picture size of 240 mm x 203 mm Maximum contrast no less than 30 footlamberts (fl)
Horizontal rate timing	
- Frequency timing	54.054 kHz
- Front porch	160 ns
- Sync pulse	1,850 ns
- Back porch	1,680 ns
- Blanking interval	3.70 μs maximum
- Active video time	14.8 μs
- Horizontal period	18.5 μs

(continued on next page)

**Table A-6 (Cont.). VR150 Monitor Specifications**

---

- Pixels displayed	1,024
Vertical rate timing	
- Frequency	60 Hz
- Front porch	0 horizontal lines
- Sync pulse	3 horizontal lines
- Blanking interval	37 horizontal lines
- Active video time	16.0 ms
- Vertical period	16.67 ms
- Lines displayed	864
Video rate (bandwidth)	
- Pixel frequency	70 MHz
- Pixel period	14.45 ns nominal
Power	
- AC input voltage	88-132/185-254 Vac
- Frequency	50/60 Hz
- Power consumption	70 watts nominal

---

**Table A-7. VR150 Monitor Operating Conditions**

---

Temperature range	10° C to 40° C (50° to 104° F)
Relative humidity	10% to 95%, noncondensing
Maximum wet-bulb temperature	32° C ( 89° F)
Minimum dew-point temperature	2° C (36° F)
Altitude	2,400 m (8,000 ft) at 36° C (96° F)

---

**Table A-8. VR150 Monitor Nonoperating Conditions**

---

Temperature range	-40° C to 66° C (-40° F to 150° F)
Relative humidity	10% to 95%, noncondensing
Maximum wet-bulb temperature	46° C (115° F), packaged
Minimum dew-point temperature	2° C (36° F)
Altitude	4,900 m (16,000 ft) at 36° C (96° F)

---

**Table A-9. VR160 Monitor Description**

	Weight	Height	Width	Depth
Monitor	23 kg (51 lb)	39.4 cm (15.5 in.)	36.9 cm (14.5 in.)	45.7 cm (18 in.)

**Table A-10. VR160 Monitor Specifications**

External controls and indicators	Brightness Contrast Degauss Power switch Power indicator
Tilt range	-7° to + 16°
Swivel range	± 60°
Display	
- Cathode ray tube (CRT)	383 mm (15 in.) diagonal Color phosphor, medium persistence P22 RGB phosphor Color 0.28 pitch shadow mask High-efficiency antiglare treatment; reflects less than 1% of incident light within the visible spectrum
- Video input	Composite video Red: 0.7 Vpp/75 ohm Green (with sync): 1 Vpp/75 ohm Blue: 0.7 Vpp/75 ohm
- Display characteristics	1,024 pixels horizontal x 864 lines vertical, giving approximate picture size of 240 mm x 203 mm Maximum contrast no less than 30 footlamberts (f)
Power	
- Voltage range (switch selectable)	DA model, 88 - 132 Vac D3, D4 models, 185 - 264 Vac

(continued on next page)

**Table A-10 (Cont.). VR160 Monitor Specifications**

---

- Frequency	50/60 Hz
- Power consumption	125 watts/200 VA nominal 150 watts/250 VA maximum

---

**Table A-11. VR160 Monitor Operating Conditions**

---

Temperature range	10° C to 40° C (50° to 104° F)
Relative humidity	10% to 95%, noncondensing
Maximum wet-bulb temperature	32° C (89° F)
Minimum dew-point temperature	2° C (36° F)
Altitude	2,400 m (8,000 ft) at 36° C (96° F)

---

**Table A-12. VR160 Monitor Nonoperating Conditions**

---

Temperature range	-40° C to 66° C (-40° F to 151° F)
Relative humidity	10% to 95%, noncondensing
Maximum wet-bulb temperature	46° C (115° F), packaged
Minimum dew-point temperature	2° C (36° F)
Altitude	4,900 m (16,000 ft) at 36° C (96° F)

---

**Table A-13. VR262 Monitor Description**

	Weight	Height	Width	Depth
Monitor	18 kg (40 lb)	39.4 cm <sup>1</sup> (15.5 in.)	45.5 cm (17.9 in.)	39.5 cm (15.4 in.)

<sup>1</sup>Including feet

**Table A-14. VR262 Monitor Specifications**

External controls and indicators	Brightness Contrast Power switch Power indicator
Video format	Composite Video Black negative 60 MHz bandwidth
Cathode-Ray Tube (CRT) display characteristics	High resolution Paper white phosphor Spot size approximately 0.3 mm Maximum 1,024 pixels (horizontal) x 864 pixels (vertical), giving an approximate picture size of 334 mm x 282 mm High-efficiency antiglare treatment
Horizontal rate timing nominal	
- Frequency	54.054 kHz
- Front porch	160 ns
- Sync pulse	1,850 ns
- Back porch	1,690 ns
- Blanking interval	3.70 $\mu$ s maximum
- Active video time	14.8 $\mu$ s
- Horizontal period	18.5 $\mu$ s
- Pixels displayed	1,024

(continued on next page)

**Table A-14 (Cont.). VR262 Monitor Specifications**

---

Vertical rate timing (nominal)

- Frequency	60 Hz
- Front porch	0 horizontal lines
- Sync pulse	3 horizontal lines
- Blanking interval	37 horizontal lines
- Active video time	16.0 ms
- Vertical period	16.67 ms
- Lines displayed	864

Power

- Power supply type	Transistor, switch type ac to dc converter
- AC input	Switch-selectable
- 100 V to 120 V	Single-phase, 3-wire 88 V to 132 V rms, 47 Hz to 63 Hz line frequency (nominal)
- 220 V to 240 V	Single-phase, 3-wire 185 V to 264 V rms, 47 Hz to 63 Hz line frequency (nominal)
- Power consumption	65 watts approximately

Fuse

100 to 120 Vac: 1 A  
6.35 mm x 31.8 mm (1/4 x 1-1/4 in.) slow blow  
(Digital PN 90-07212-00)  
(220 Vac 240 Vac: 1A  
5 mm x 20 mm time lag  
(Digital PN 12-19283-00)

---

**Table A-15. VR262 Monitor Operating Conditions**

---

Temperature range	10° C to 40° C (50° F to 104° F)
Temperature change rate	11° (20° F) per hour maximum
Relative humidity	10% to 90%, noncondensing
Maximum wet-bulb temperature	28° C (82° F)
Minimum dew-point temperature	2° C (36° F)

---

**Table A-16. VR262 Monitor Nonoperating Conditions**

---

Temperature range	-40° C to 66° C (-40° F to 151° F)
Relative humidity	10% to 95%, noncondensing
Maximum wet-bulb temperature	46° C (115° F), packaged
Minimum dew-point temperature	2° C (36° F)

---

**Table A-17. VR299 Monitor Description**

	<b>Weight</b>	<b>Height</b>	<b>Width</b>	<b>Depth</b>
Monitor	32 kg (70 lbs)	47 cm (18.5 in.)	50.6 cm (19.9 in.)	52.5 cm (20.7 in.)

**Table A-18. VR299 Monitor Specifications**

External controls, switches, and indicators	Brightness Contrast Degauss Power switch Power indicator Voltage selector switch
Tilt range	-5° to + 150°
Swivel range	± 200°
Display	
- Cathode ray tube (CRT)	508 mm (20 in.) diagonal Color phosphor, medium persistence P22 RGB phosphor Color 0.32 mm pitch shadow mask High-efficiency antiglare treatment; reflects less than 1% of incident visible light
- Video input	Composite video Red: 0.7 Vpp/75 ohm Green (with sync): 0.7 Vpp/75 ohm Blue: 0.7 Vpp/75 ohm
- Display characteristics	1,024 pixels horizontal x 864 lines vertical, giving approximate picture size of 326 mm x 275 mm Contrast 35 footlamberts (fl) maximum
Horizontal rate timing	
- Frequency timing	54.054 kHz
- Front porch	159 ns
- Sync pulse	1,850 ns
- Back porch	1,680 ns

(continued on next page)

**Table A-18 (Cont.). VR299 Monitor Specifications**

---

- Blanking interval	3.69 $\mu$ s maximum
- Active video time	14.8 $\mu$ s
- Horizontal period	18.5 $\mu$ s
- Pixels displayed	1,024

Vertical rate timing

- Frequency	60 Hz
- Front porch	0 horizontal lines
- Sync pulse	3 horizontal lines
- Blanking interval	37 horizontal lines
- Active video time	16.0 ms
- Vertical period	16.67 ms
- Lines displayed	864

Video rate (bandwidth)

- Pixel frequency	70 MHz
- Pixel period	14.45 ns nominal

Power

- AC input voltage (switch selectable)	88-132/185-254 Vac
- Frequency	50/60 Hz
- Power consumption	150 watts maximum

Fuse

3.2 A for 120 V system  
1.6 A for 240 V system

EMI standards

Complies with FCC and VDE Class A standards  
when brightness and control are at maximum

---

**Table A-19. VR299 Monitor Operating Conditions**

---

Temperature range	10° C to 40° C (50° to 104° F)
Relative humidity	10% to 95%, noncondensing
Maximum wet-bulb temperature	32° C ( 89° F)
Minimum dew-point temperature	2° C (36° F)
Altitude	2,400 m (8,000 ft) at 36° C (96° F)

---

**Table A-20. VR299 Monitor Nonoperating Conditions**

---

Temperature range	-40° C to 66° C (-40° F to 150° F)
Relative humidity	10% to 95%, noncondensing
Maximum wet-bulb temperature	46° C (115° F), packaged
Minimum dew-point temperature	2° C (36° F)
Altitude	4,900 m (16,000 ft) at 36° C (96° F)

---

**Table A-21. LK201 Keyboard Description**

	<b>Weight</b>	<b>Height</b>	<b>Width</b>	<b>Depth</b>
Keyboard	2 kg (4.5 lb)	51 mm (2 in.)	533 mm (21 in.)	171 mm (6.75 in.)

**Table A-22. LK201 Keyboard Specifications**

Number of keys	105
Number of indicators	4 status LEDs
Language variations	15
Diagnostics	Self-testing and self-identifying with respect to revision level but not with respect to language variants
Cable	1.76 m (6 ft) uncoiled, detachable; 4-pin mmj connector at both ends
Baud rate	4800
Power consumption	4.2 watts maximum
Power input	11.8 V +/- 6% @ 350 ma
Electrical interface	EIA RS 423
Volume control	8 levels, plus off; maximum 65 dba 1 ft above keyboard
Keystroke timing	20 Msec minimum

**Table A-23. LK201 Keyboard Operating Conditions**

Temperature range	10° C to 40° C (50° F to 104° F)
Relative humidity	10% to 90%
Maximum wet-bulb temperature	28° C (82° F)
Minimum dew-point temperature	2° C (36° F)
Altitude	2,400 m (8,000 ft) at 36° C (96° F)

**Table A-24. LK201 Keyboard Nonoperating Conditions**

---

Temperature range	-40° C to 66° C (-40° F to 151° F)
Relative humidity	10% to 95%, noncondensing
Maximum wet-bulb temperature	46° C (115° F), packaged
Minimum dew-point temperature	2° C (36° F)
Altitude	49,000 m (16,000 ft) at 36° C (96° F)

---

**Table A-25. VSXXX-AA Mouse Description**

	Weight	Height	Diameter
Mouse	0.82 kg (0.37 lb)	4 cm (1.57 in.)	8.8 cm (3.47 in.)

**Table A-26. VSXXX-AA Mouse Specifications**

Baud rate	4800
Cable length	1.5 m (5 ft), shielded, 6 conductors and terminals in a 7-pin micro-DIN-type connector (male)
Resolution	79 counts/(200 counts/in.)
Tracking speed	73.5 cm (30 in./sec)
Electrical interfaces	EIA RS-232-C or TTL
Operating modes	Incremental or polling
Tracking rate	In incremental mode: 55 reports/sec In polling mode: up to 95 reports/sec
Accuracy	+/-3% 0 to 24.5 cm/sec (0 to 10 in./sec) any direction +/-15% 24.5 to 49 cm/sec (10 to 20 in./sec) any direction +/-30% 49 to 73.5 cm/sec (20 to 30 in./sec) any direction
Data format	Delta binary
Buttons	3
Diagnostics	Self-testing and self-identifying with respect to revision level
Power requirements	+5 V +/-5% at 130 mA -12 V +/- 10% at 20 mA

**Table A-27. VSXXX-AA Mouse Operating Conditions**

Temperature range	10° C to 40° C (50° F to 104° F)
Relative humidity	10% to 90%, noncondensing
Maximum wet-bulb temperature	28° C (82° F)
Minimum dew-point temperature	2° C (36° F)
Altitude	2,400 m (8,000 ft) at 36° C (96° F)

**Table A-28. VSXXX-AA Mouse Nonoperating Conditions**

---

Temperature range	-40° C to 66° C (-40° F to 151° F)
Relative humidity	5% to 95%
Maximum wet-bulb temperature	46° C (115° F), packaged
Minimum dew-point temperature	2° (36° F)
Altitude	4,900 m (16,000 ft) at 36° C (96° F)

---

**Table A-29. RZ55 SCSI Hard Disk Drive Description**

	Weight	Height	Width	Depth
Expansion box	13.2 cm (29 lb)	14 cm (3.25 in.)	33 cm (12.75 in.)	29 cm (11.25 in.)
Internal drive	3.78 kg (8.4 lb)	8.25 cm (3.25 in.)	14.60 cm (5.75 in.)	20.82 cm (8.20 in.)

**Table A-30. RZ55 SCSI Hard Disk Drive Specifications**

Capacity	332.3 Mbytes
- Per surface	22.48 Mbytes
- Per track	18,432
- Per block	512 bytes
Blocks	36 per track 649,040 per drive
Spare blocks	8 per track 10,300 per drive
Transfer rate to/from media	1.25 Mbytes/sec
Bus asynchronous mode	1.5 Mbytes/sec
Bus synchronous mode	4 Mbytes/sec
Seek time	<= 4 Msec track-to-track <= 16 Msec average <= 35 Msec maximum
Average latency	8.3 Msec
Rotational speed	3,600 RPM
Start time	20 sec maximum
Stop time	20 sec maximum
Interleave	1:1
Bus latency	600 $\mu$ sec maximum
Heat dissipation	32 watts maximum
Recording density (bpi at ID)	21,231
Track density (Epi)	1,075
Tracks/surface (unformatted)	1,224
R/W heads	15

**Table A-31. RZ55 SCSI Hard Disk Drive Operating Conditions**

---

Temperature range <sup>1</sup>	10° C to 55° C (50° F to 131° F)
Relative humidity	20% to 80%, noncondensing
Maximum wet-bulb temperature	25.6° C (78° F)
Minimum dew-point temperature	2° C (36° F)
Altitude	-304 to 4,600 m (-1,000 to 15,000 ft) at 36° C (96° F)

---

<sup>1</sup>Reduce maximum temperature by 1.8° C (3.24° F) for each 1,000-meter increase in altitude.

---

**Table A-32. RZ55 SCSI Hard Disk Drive Nonoperating Conditions**

---

Temperature range	-40° C to 66° C (-40° F to 151° F)
Relative humidity	20% to 95%, packaged
Maximum wet-bulb temperature	46° C (115° F), packaged
Minimum dew-point temperature	2° C (36° F)
Altitude	-304 to 12,300 m (-1,000 ft to 40,000 ft) at 36° C (96° F)

---

**Table A-33. TK50Z Tape Drive Description**

	Weight	Height	Width	Depth
Expansion box	12.7 kg (28 lb)	14 cm (5.5 in.)	33 cm (12.75 in.)	29 cm (11.25 in.)

**Table A-34. TK50Z Tape Drive Specifications**

Mode of operation	Streaming
Media	12.77 mm (1/2 in.), 600 ft. long magnetic tape
Bit density	6,667 bits/in.
Number of tracks	22
Transfer rate (at host)	360 Kbits/sec (45 Kbytes/sec)
Type speed	75 in./sec
Track format	Serpentine
Cartridge capacity	131 Mbytes, unformatted
Power requirements	+12 Vdc +/-5% + 5 Vdc +/-5%
Input current	2.4 amps at 100 to 120 Vac 1.3 amps at 220 to 240 Vac
Power	160 watts
Frequency	50 to 60 Hz
Heat dissipation	32 watts maximum

**Table A-35. TK50Z Tape Drive Operating Conditions**

Temperature range <sup>1</sup>	10° C to 40° C (50° F to 104° F)
Relative humidity	10% to 80%, noncondensing
Maximum wet-bulb temperature	28° C (82° F)
Minimum dew-point temperature	2° C (36° F)
Altitude	2,400 m (8,000 ft) at 36° C (96° F)

<sup>1</sup>Reduce maximum temperature by 1.8° C (3.24° F) for each 1,000-meter increase in altitude.

**Table A-36. TK50Z Tape Drive Nonoperating Conditions**

---

Temperature range	-30° C to 66° C (-22° F to 151° F)
Relative humidity	10% to 95%, noncondensing
Maximum wet-bulb temperature	46° C (115° F), packaged
Minimum dew-point temperature	2° C (36° F)
Altitude	9.1 km (30,000 ft) at 36° C (96° F)

---

**Table A-37. RRD40 Compact Disc Drive Description (Tabletop)**

	Weight	Height	Width	Depth
Expansion box	4.0 kg (8.8 lb)	76.2 mm (3 in.)	229 cm (9.125 in.)	280 cm (11 in.)

**Table A-38. RRD40 Compact Disc Drive Specifications (Tabletop)**

Capacity per disc	635 Mbytes
Access time	Maximum 1,000 Msec, including latency average 500 Msec
Average latency	155 Msec at outer track 60 Msec at inner track
Average transfer rate	175.2 Kbytes/sec
Initialization startup time	Less than 6 sec
Heat dissipation	14 watts (typical)

**Table A-39. RRD40 Compact Disc Drive Operating Conditions (Tabletop)**

Temperature range <sup>1</sup>	10° C to 50° C (50° F to 122° F)
Relative humidity	10% to 80%, noncondensing
Maximum wet-bulb temperature	28° C (82° F)
Minimum dew-point temperature	2° C (36° F)
Altitude	3400 m (11,150 ft) at 36° C (96° F)

<sup>1</sup>Reduce maximum temperature by 1.8° C (3.24° F) for each 1,000-meter increase in altitude.

**Table A-40. RRD40 Compact Disc Drive Nonoperating Conditions (Tabletop)**

Temperature range	4° C to 70° C (40° F to 158° F)
Relative humidity	5% to 95%, noncondensing
Maximum wet-bulb temperature	46° C (115° F), packaged
Minimum dew-point temperature	2° C (36° F)
Altitude	13,600 m (44,600 ft) at 36° C (96° F)

**Table A-41. RZ23 SCSI Hard Disk Drive Description**

	Weight	Height	Width	Depth
Internal drive	0.826 kg (1.82 lb)	41.28 mm (1.625 in.)	10.16 cm (4.00 in.)	14.6 cm (5.75 in.)

**Table A-42. RZ23 SCSI Hard Disk Drive Specifications (formatted)**

Capacity	104 Mbytes
- Per surface	13 Mbytes
- Per track	16,896 bytes
- Per block	512 bytes
Blocks	33 per track 204,864 per drive
Spare block	1 per track 6208 per drive
Transfer rate	1.25 Mbytes/sec to/from media 1.25 Mbytes/sec to/from buffer
Seek time	<= 8 Msec track-to-track <= 25 Msec average <= 45 Msec average
Average latency	8.4 Msec
Rotational speed	3575 RPM +/- 0.1%
Start time	20 sec maximum
Stop time	20 sec maximum
Interleave	1:1

**Table A-43. RZ23 SCSI Hard Disk Drive Operating Conditions**

Temperature range	10° C to 60° C (50° F to 140° F)
Temperature change rate	11° C (20° F) per hour
Relative humidity	8% to 80%, noncondensing
Maximum wet-bulb temperature	26° C (78° F)
Minimum dew-point temperature	2° C (36° F)
Altitude	3050 m (10,000 ft) at 36° C (96° F)
Heat dissipation, average	8 watts

**Table A-44. RZ23 SCSI Hard Disk Drive Nonoperating Conditions**

---

Temperature range	-40° C to 66° C (-40° F to 151° F)
Temperature change rate	20° C (36° F) per hour
Relative humidity	8% to 95%, packaged
Maximum wet-bulb temperature	46° C (115° F), packaged
Minimum dew-point temperature	2° C (36° F)
Altitude	-304 m to 12,200 m (-1,000 ft) to (40,000 ft) at 36° C (96° F)

---

---

**Part Numbers****Table B-1. Basic Components**

<b>Item</b>	<b>Order Number</b>
15-inch monochrome monitor, 120 volts	VR150-AA
15-inch monochrome monitor, 240 volts	VR150-A3
15-inch color monitor, 120 volts	VR160-DA
15-inch color monitor, 240 volts, Northern Hemisphere	VR160-D3
15-inch color monitor, 240 volts, Southern Hemisphere	VR160-D4
19-inch monochrome monitor, 120 volts	VR262-AA
19-inch monochrome monitor, 240 volts	VR262-A3
19-inch color monitor, 120 volts	VR299-DA
19-inch color monitor, 240 volts, Northern Hemisphere	VR299-D3
19-inch color monitor, 240 volts, Southern Hemisphere	VR299-D4
External disk drive, 332 Mbytes, 120 volts	RZ55-FA
External disk drive, 332 Mbytes, 240 volts	RZ55-F3
Optical compact disc drive, 600 Mbytes, 120 volts	RRD40-FA
Optical compact disc drive, 600 Mbytes, 240 volts	RRD40-F3
Internal disk drive, 104 Mbytes	RZ23-FF
Memory expansion	MS01-AA
Monochrome video SIM module	VFB01

(continued on next page)

**Table B-1 (Cont.). Basic Components**

Item	Order Number
Color video SIM module	VFB02
Tape drive, 95 Mbytes, 120 volts	TK50Z-GA
Tape drive, 95 Mbytes, 240 volts	TK50Z-G3
Mouse	VSXXX-AA

**Table B-2. Cords, Cables, and Connectors**

Item	Part Number	Order Number
Expansion box power cord	17-00606-10	—
Monitor-system unit cable (US)	17-00442-26	—
Power supply to internal disks cable	17-02225-01	—
SCSI cover	74-38189-01	—
SCSI 68-pin terminator	12-29635-01	—
SCSI internal cable (DECstation 2100/3100 only)	17-02358-01	
SCSI internal cable (DECstation 3100S only)	17-02358-02	
Serial line cable	—	BC16E-10
System unit power cord (U.S.)	17-00606-10	—
ThickWire cable	—	BNE4C-02
ThickWire loopback connector	12-22196-01	—
ThinWire T-connector	12-25534-01	H8223
ThinWire terminator	12-25535-01	H8225
ThinWire cable (12 ft)	17-01241-09	BC16M-12
ThinWire LAN assembly kit	22-00112-01	BC16T-12
Video cable, monochrome	17-01993-01	BC23K-03
Video cable, color	17-01992-01	BC23J-03
68-pin to 50-pin system unit-expansion box SCSI cable	17-02008-01	BC56H-03 Rev. B01
18-inch 50-pin to 50-pin SCSI cable	—	BC19J-1E
50-pin SCSI terminator for expansion box	12-30552-01	—

**Table B-3. Software Documentation**

<b>Item</b>	<b>Order Number</b>
<b>ULTRIX Media and Doc-TK50</b>	QA-VV1AA-H5
<i>Technical Summary for RISC Processors</i>	AA-MM35A-TE
<i>Documentation Overview for RISC Processors</i>	AA-MM05A-TE

**Table B-4. Hardware Documentation**

<b>Item</b>	<b>Order Number</b>
<b>DECstation 2100/3100 User Documentation Kit</b>	EK-308AA-DK-002
<i>DECstation 2100/3100 Maintenance Guide</i>	EK-291AA-MG-002
<b>Components and Add-Ons</b>	
<i>The RZ22/23 Disk Drive Service Manual</i>	EK-RZ223-SV
<i>The RZ55 Disk Drive Service Manual</i>	EK-RZ55D-SV
<i>Installing and Using the LN03</i>	EK-0LN03-UG
<i>LN03 PLUS User Guide</i>	EK-LN03S-UG
<i>ScriptPrinter Installation Guide</i>	EK-LN03R-UG
<i>ScriptPrinter Operator Guide</i>	EK-LN03R-OG
<i>LA100 Letterwriter User Documentation Kit</i>	EK-LW100-UG
<i>Installing and Using the LA75 Companion Printer</i>	EK-0LA75-UG
<i>Installing and Using the LJ250/252 Companion Color Printer</i>	EK-LJ250-DK
<i>TK50Z Tape Drive Subsystem Owner's Manual</i>	EK-LEP05-OM
<i>TK50Z User's Guide</i>	EK-OTK50-UG
<i>Technical Manual</i>	EK-OTK50-TM

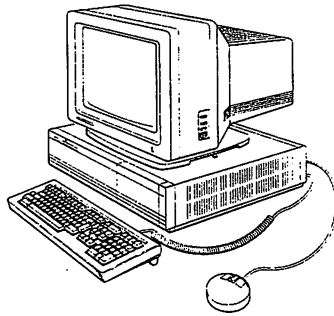

---

## Console Commands

Your workstation functions in two modes: program I/O mode and console I/O mode. Program I/O mode is the normal operating mode in which you interact with your terminal. Console I/O mode allows low-level communication between the user and DECstation 2100/3100 hardware. You can use it for such operations as booting the operating system, setting up automatic booting, setting baud rates, and examining memory.

On power up, your workstation automatically enters console mode after the self-test completes, unless you have programmed automatic boot-strapping. You can also invoke the console program by halting the operating system.

The console program displays the prompt >> when it is ready to accept commands. Observe the following rules when typing console commands:

- All commands typed at console level are case sensitive. The workstation does not recognize uppercase and lowercase letters as the same input.
- Command execution begins when you press the Return key.
- Enter numeric values as follows:
  - Enter *decimal values* as a string of decimal digits with no leading zeros (for example, 123).
  - Enter *octal values* as a string of octal digits with a leading zero (for example, 0177).
  - Enter *hexadecimal values* as a string of hexadecimal digits preceded by 0x (for example, 0x3ff).
  - Enter *binary values* as a string of binary digits preceded by 0b (for example, 0b1001).
- When reading or writing to memory, you have a choice of data sizes: byte, halfword, or word. Because a word is 4 bytes, successive addresses, when referenced by a word, are successive multiples of 4. For example, the address following 0x80000004 is 0x80000008. An error will occur if you try to specify an address that is not on a boundary for the data size you are using.

- The following key combinations have an immediate effect in console mode:
  - Ctrl-S stops output to the screen.
  - Ctrl-Q resumes output to the screen.
  - Ctrl-C aborts execution of a command.
  - Ctrl-U erases a partially typed command line.

## Conventions Used in This Appendix

- Letters in roman type are to be typed exactly as they appear.
- Letters in italics represent arguments for which you supply values. (Note that your help and menu screens display these arguments in all capital letters.)
- Arguments enclosed in square brackets ([ ]) are optional.
- Ellipses (...) follow an argument that can be repeated.
- A vertical bar ( | ) separates choices. You can think of it as a symbol meaning *or*.
- Parentheses are used as in algebraic expressions. For example,

-(b | h | w)

means enter -b or -h or -w.

## Getting Help

You can get help with console command syntax in several ways:

- You can type the word **help** or a question mark (?) to display a menu of all console commands.
- You can enter the name of the command for which you want help as an argument to help or ?.

For example, entering **? e** at the console prompt (>>) displays the syntax for the examine (e) command:

```
e [- (b|h|w)] ADDR  
>>
```

- If you type an incorrect command line, you get a help screen.

For example, the e command requires an *addr* argument. Typing **e -b** at the console prompt (>>) without entering an address causes the screen to display the correct syntax for the command:

```
e [- (b|h|w)] ADDR  
>>
```

## Console Commands

Table C-1 lists the console commands.

**Table C-1. Console Commands**

Command	Description
auto	Starts automatic bootstrapping.
boot	Boots the operating system.
ctrs	Displays network counters.
d	Deposits data at a given address.
disable	Disables a device.
dump	Dumps memory to the screen.
e	Examines memory.
enable	Enables a device.
fill	Deposits data in an address range.
go	Resumes execution of the program in memory.
help	Displays the syntax of console commands.
?	Displays the syntax of console commands.
init	Reinitializes memory.
printenv	Displays console environment variables.
setenv	Sets console environment variables.
test	Runs tests or displays the system configuration.
unsetenv	Unsets console environment variables.

In addition to the commands described in Table C-1, two other commands—`cat` and `warm`—also show on the help menu. These commands are not supported at this time.

Commands, such as the `scsi` and `t` commands, that do not appear on the help menu are documented in the *DECstation 2100/3100 Maintenance Guide*.

## The auto Command

auto

This command starts the automatic bootstrapping sequence that puts the workstation into multiuser mode (the normal time-sharing environment).

The workstation boots according to the bootpath variable stored in the environment variables table.

Execution is delayed for 5 seconds after you press Return. To abort the auto command, you can type Ctrl-C during this 5-second delay.

## The boot Command

boot [-f *file*] [-n] [*arg...*]

This command loads the file that contains the operating system.

- The optional -f flag followed by the *file* parameter specifies the file you want to use during a boot procedure. If you do not specify the -f flag and a file, the file specified by the environment variable *bootpath* is loaded.

The *file* parameter has the format

*dev*[[*controller*][,*unit-number*] [,*partition-number*]][*filename*]

- *dev* indicates the device from which you are booting the operating system. Typical devices are rz for a hard disk, tz for a tape, and mop for a network. Typing **mop** nullifies the other arguments in the list, so that *file* takes the form mop().
- *controller* indicates the ID number of the default controller. On the DECstation 2100/3100 workstation, this number is always 0.

- *unit-number* indicates the unit number of the device from which you are booting the operating system. To display a list of devices and their unit numbers, enter `test -c` at the console prompt (`>>`).
- *partition-number* indicates the number (or other designator) of the partition from which you are booting the operating system. When booting from a tape, this number is not used because the boot file must be the first thing on the tape. When booting from a disk, this number depends on how you partitioned the disk when you installed your operating system software. Refer to your software installation manual if you need a reminder about disk partition indicators.
- *file name* indicates the name of the operating system file.
  - The optional `-n` flag causes the specified file to be loaded but not executed.
  - The optional *arg* parameter contains any information to be passed to the booted image.

Examples:

```
>> boot -f rz(0,0,0)vmunix
```

This command boots the file `vmunix`, located in the A partition of the first hard disk (unit number 0), using controller, 0.

```
>> boot -f rz(0,4,c)vmunix
```

This command boots the file `vmunix` from the optical compact disc drive, which is unit 4 in this example.

```
>> boot -f tz(0,5)
```

This command boots from the tape, which is unit 5 in this case.

## The ctrs Command

ctrs

This command displays all the network counters.

A typical display looks like this:

```
15905 : seconds since zeroed
  0 : bytes received
  0 : bytes sent
  0 : frames received
  0 : frames sent
  0 : multicast bytes received
  0 : multicast frames received
  0 : frames sent deferred
  0 : frames sent, single collision
  0 : frames sent, multiple collision
  0 : send failures
  0 : send failure bitmap
  0 : receive failures
  0 : receive failure bitmap
  0 : unrecognized destinations
  0 : data overruns
  0 : unavailable system buffers
  0 : unavailable user buffers
```

**Note:** *The counter values will not be zero after an ethernet boot.*

## The **d** (deposit) Command

`d [-b | h | w] addr val`

This command deposits a single byte, halfword, or word value at the specified address.

The first parameter, which is optional, indicates the data size. If not given, data size defaults to word. If you do not specify a data size, a word is used.

- Use `-b` to deposit 1 byte of data
- Use `-h` to deposit a halfword (2 bytes) of data
- Use `-w` to deposit a word (4 bytes) of data

The *addr* parameter indicates the address to which you want data written. System address space ranges from 0x80000000 to 0xBF000000.

The *val* parameter contains the data you want deposited at the given address.

Example:

```
>> d -w 0x80000000 0xFFFFFFFF
```

This command deposits the value 0xFFFFFFFF, with a data size of one word, at address 0x80000000.

## The disable Command

```
disable [dev]
```

This command disables the connection to a specified device. It also removes the device from the list of recognized console terminals stored in volatile memory.

The optional *dev* parameter indicates the device you are disabling. If you do not specify *dev*, `disable` displays the list of currently enabled console devices. The *dev* parameter has the format `tty (n) | crt(0)`.

- `tty(n)`, where *n* is a serial line, specifies a printer, console, or communications device.

Specify 2 for a communications connector and 3 for a printer/console connector.

For example, to disable an alternate console, enter

```
disable tty(3)
```

- `crt(0)` specifies the workstation monitor.

## The dump Command

```
dump [-(b | h | w)] [-(o | d | u | x | c | B)] rng
```

This command shows a formatted display of the contents of memory.

The first parameter, which is optional, indicates the data size. If not given, data size defaults to word. If you do not specify a data size, the system uses a word.

- `-b` displays memory in bytes.
- `-h` displays memory in halfwords.
- `-w` displays memory in words.

The next parameter, also optional, determines how data is displayed.

- `-o` displays memory in octal format.
- `-d` displays memory in decimal format.
- `-u` displays memory in unsigned decimal format.
- `-x` displays memory in hexadecimal format.
- `-c` displays memory in ASCII format.
- `-B` displays memory in binary format.

If no format argument is given, hexadecimal format is used.

The *rng* parameter indicates the range of memory you want to see. You can specify the range in one of two ways:

- *addr#cnt* displays the number of addresses specified by *cnt*, beginning at *addr*.
- *addr:adr* displays all values between the specified addresses.

Examples:

```
>> dump 0x80000000#0xf
```

This command uses hexadecimal format to dump the first 15 words of memory to the screen.

```
>> dump -b 0x80000000#0xf
```

This command uses hexadecimal format to dump the first 15 bytes of memory to the screen. The dump display shows rows of address contents. The left-most column gives the address of the first field in each row.

## The e (examine) Command

```
e [-(b | h | w)] addr
```

This command examines the byte, halfword, or word at the specified address.

The first parameter, which is optional, indicates the data size. If not given, data size defaults to word. If you do not specify the data size, a word is used.

- -b indicates a single byte.
- -h indicates a halfword.
- -w indicates a word.

The *addr* parameter indicates an address in the range 0x80000000 to 0xBF000000.

When you enter the examine command, a display similar to the following appears:

```
0x80000005: 65 0x41 'A'
```

The left-most field echoes the address you entered.

The next three fields display the contents of the address in decimal, hexadecimal, and ASCII formats, respectively. If the ASCII character is unprintable, it is displayed as an octal value preceded by a backslash: for example, '\032'.

**Example:**

```
>> e 0x80000000
```

This command examines the word at address 0x80000000. The resulting display might look like this:

```
0x80000000:          1008385985          0x3c1abfc1          '\301'
```

## The enable Command

enable [*dev*]

This command enables the connection to a specified device. It also adds the device to the list of current console devices stored in volatile memory.

The optional *dev* parameter indicates the device you are enabling. If you do not specify *dev*, enable displays the list of currently enabled console devices. The *dev* parameter has the format `tty (n) | crt(0)`

- `tty(n)`, where *n* is a serial line, specifies a printer, console, or communications device.

Specify 2 for a communications connector and 3 for a printer/console connector.

For example, to enable an alternate console, enter **enable tty(3)** at the console prompt (>>).

- `crt(0)`, specifies the workstation monitor.

You can enable more than one device as a console device.

## The fill Command

```
fill [-(b | h | w)] [-v val] rng
```

This command writes a specified value to a range of memory. If you do not specify a value, the workstation puts zeros in the memory range.

The first parameter, which is optional, indicates the data size. If not given, data size defaults to word.

- -b indicates bytes.
- -h indicates halfwords.
- -w indicates words.

The optional parameter -v *val* specifies the numeric value to write to memory. If you do not specify a value, all zeros are written. If the size of *val* does not match the data size parameter, *val* is truncated or expanded as necessary.

The *rng* parameter indicates the memory range. You can specify the range in one of two ways:

- *addr#cnt* fills addresses beginning at *addr* and continuing for *cnt* locations.
- *addr:addr* fills all locations between the two given addresses.

Example:

```
>> fill -v 0xffffffff 0x80000010:0x800000ff
```

This command sets all bits to 1 at addresses 16 to 255.

## The go Command

`go [pc]`

This command transfers control to the indicated entry-point address.

The optional *pc* parameter indicates the entry-point address you want to use.

If you do not specify an entry-point address, the workstation uses the entry point of the program module that was most recently loaded. If no program module was previously loaded, the workstation uses 0 as the entry-point address.

## The help Command

`help [cmd]`

This command displays the correct syntax for the console commands.

The optional *cmd* parameter indicates the command for which you want information. If you do not specify *cmd*, the complete console menu appears.

## The ? Command

`? [cmd]`

This command functions exactly like the help command.

## The init Command

`init`

This command fully initializes the system.

The effect of the `init` command is identical to turning the power on or pressing the reset button, except that the workstation does not execute its self-test.

## The printenv Command

`printenv [ivar...]`

This command displays the current value for the specified environment variable.

The optional *ivar* parameter indicates the variable whose value you want to see. If you do not specify a variable, the complete environment variables table appears. A typical display looks like this:

```
baud2=1200
baud3=9600
bootpath=
bootmode=*
console=0
systype=0x82011601
bitmap=0xa000fcc0
bitmaplen=0xc0
inetaddr=0
osconsole=1
```

There are three types of variables: volatile (lost when power resumes), nonvolatile (maintained after power resumes), and fixed (rebuilt when power is turned on). Table C-2 lists the default variables.

**Table C-2. Default Environment Variables**

<b>Variable</b>	<b>Type</b>	<b>Description</b>
<i>baud2</i>	Nonvolatile	Indicates the baud rate of the communications connector.
<i>baud3</i>	Nonvolatile	Indicates the baud rate of the printer/console connector.
<i>bootpath</i>	Nonvolatile	Indicates the default bootpath. The workstation uses this variable when you type the auto command.
<i>bootmode</i>	Nonvolatile	Determines what programs run when the workstation is turned on or reset. Use one of the following codes: <ul style="list-style-type: none"><li>* The default code; makes the console program active on the workstation</li><li>a Boots the operating system using the <i>bootpath</i> variable</li><li>d Resets the workstation without running the self-test</li><li>r Restarts the workstation</li></ul>

(continued on next page)

**Table C-2 (Cont.). Default Environment Variables**

<b>Variable</b>	<b>Type</b>	<b>Description</b>
<i>console</i>	Nonvolatile	Determines which device is used for the console when the workstation is started. Use one of the following values to set this variable:  0 Lets the system choose the console device.  1 Specifies the workstation monitor, crt(0), and the keyboard connector, tty(0).  4 Specifies the communications connector, tty(2).  8 Specifies the printer/console connector, tty(3).  9 Specifies the workstation monitor, crt(0); the keyboard connector, tty(0); and the printer/console connector, tty(3).

(continued on next page)

**Table C-2 (Cont.). Default Environment Variables**

Variable	Type	Description
<i>systype</i>	Fixed	A value taken from the hardware register in the central processing unit. Do not change this variable.
<i>bitmap</i>	Fixed	Indicates the address of the memory bitmap. The bitmap keeps track of good and bad memory pages. Each bit corresponds to one page in memory; 1 indicates the page is good, and 0 indicates the page is bad. Do not change this variable.
<i>bitmaplen</i>	Fixed	Indicates the length of the memory bitmap. Do not change this variable.
<i>inetaddr</i>	Volatile	Indicates the workstation's internet address. This variable is used by the Ethernet driver.
<i>osconsole</i>	Volatile	Set by the system power up to indicate which device the workstation selected as the console. Values have the same meaning as for the <i>console</i> variable. The <i>osconsole</i> and <i>console</i> variables have the same value except when <i>console</i> is 0 or set to a value the system cannot use.

## The setenv Command

`setenv var str`

This command assigns new values to the specified environment variable. Refer to the discussion of the `printenv` command for a description of each variable.

- The *var* parameter indicates the variable you want to set.
- The *str* parameter indicates the value you want to specify.

You can also add your own environment variables. These variables are stored in volatile memory. The environment variables table can contain up to 16 variables, for a total of 256 characters.

## The test Command

`test arg`

This command allows you to run the self-test or display the current configuration table.

The *arg* parameter has the following format:

`-(a/c)`

- Specify `-a` runs the self-test. This self-test is similar to the power-up self-test.
- Specify `-c` displays the configuration table. The configuration table provides such information as how much memory is installed, whether a monochrome or color video SIM module is part of your workstation, and what kind of disk or tape storage device is connected to your system.

The following is a typical configuration table:

```
MEMORY: 16Mbytes
VIDEO: MONO
ETHERNET STATION ADDRESS: 08-00-2b-0c-4a-8b
SCSI DEVICES:
Unit[7]
Unit[6]KN01--SII
Unit[5]
Unit[4]
Unit[3]
Unit[2]
Unit[1]
Unit[0] Device type  0 DISK
          RMB                0x0
          Version             1
          Response data format 1 CCS
          Additional length    31
          Vendor               DEC
          Product identification RZ55      (C) DEC
          Firmware revision level 0700
```

## The unsetenv Command

This command removes the specified variable from the environment variables table.

```
unsetenv evar
```

The *evar* parameter indicates the variable you are removing. Refer to Table C-2 earlier in this appendix for a description of each variable.

The `unsetenv` command does not affect the environment variables stored in nonvolatile memory. These variables are reset at the next reset or power cycle.

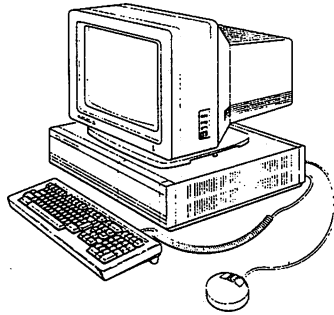

---

## Interpreting the Self-Test

This appendix tells you how to interpret power-up self-test codes displayed on the monitor screen and in the LED status display on the back of the system unit.

### Using the Power-Up Self-Test



There are two ways to interpret self-test results when a test fails:

- You can use the test codes displayed on the monitor.
- You can use the LED codes that appear on the LED status display on the back of the system unit.

Use the LED display when you cannot use the monitor to read the test codes.

## Interpreting Monitor Self-Test Codes

If a subtest fails and the results are displayed on your screen, the number of the subtest that failed is the last number displayed.

Use Table D-1 to determine where the error occurred and what action to take.

**Table D-1. Monitor Self-Test Display Codes**

Test Code	Component Tested	Action to Take if Subtest Fails
7	Video single in-line memory (video SIM) module	Contact your Digital service representative.
6	VDAC and PCC	Contact your Digital service representative.
5	DZ serial line	Contact your Digital service representative.
4	System module	Follow the SCSI troubleshooting procedures described in Chapter 6 of this guide.
3	Keyboard and mouse	Follow the keyboard and mouse troubleshooting procedures described in Chapter 6 of this guide.
2	Network interface (LANCE)	Follow the Ethernet troubleshooting procedures described in Chapter 6 of this guide.
1	Disk and SCSI bus peripherals	Contact your Digital service representative.
0	Indicates the end of the test	None; the system test has succeeded.

## Interpreting LED Self-Test Codes

If a subtest fails, the red lights glow on the LED status display on the back of the system unit. The configuration of the lights indicates the subtest that failed.

To interpret self-test results without using a monitor, use Table D-2 to determine where the error occurred and what action to take. The binary codes in the LED display column reflect the red status LED display as viewed from the back of the system unit.

**Table D-2. LED Self-Test Display Codes**

LED Display (1 = LED on, 0=LED off)	Hexadecimal Code	Component Tested	Action to Take if Subtest Fails
0111 1111	7f	System module	Contact your Digital service representative.
1011 1111	bf	Disk	Follow the SCSI troubleshooting procedures described in Chapter 6 of this guide.
1101 1111	df	Keyboard	Follow the keyboard trouble- shooting procedures described in Chapter 6 of this guide.
1110 1111	ef	Memory	Contact your Digital service representative.
1111 0111	f7	Mouse	Follow the mouse troubleshoot- ing procedures described in Chapter 6 of this guide.
1111 1111	ff	LEDs set at power up or reset	Contact your Digital service representative.

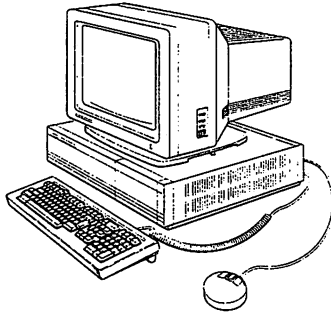

---

# Index

## A

Activity indicator light (optical compact disc drive), 5-3, 5-7, 5-8  
auto command, C-6

## B

boot command, C-6  
Booting the system  
    unsuccessful, 3-9  
Booting the worksystem software, 3-8  
Brightness control, 1-10, 6-10

## C

Caddy (optical compact disc drive), 5-4, 5-5, 5-6, 5-8  
    loading, 5-12 to 5-14  
    unloading, 5-9 to 5-11  
? command, C-15  
Commands  
    *See* Console commands  
Communications connector, 1-3  
Communications device, 1-3  
Compact disc handling  
    *See* Optical compact disc drive  
Configuration display, 3-5 to 3-7  
Configuration table, C-21  
Console commands, 3-8

## Console commands (cont'd.)

?, C-15  
auto, C-6  
boot, C-6  
ctrs, C-8  
d (deposit), C-9  
disable, C-10  
dump, C-10  
e (examine), C-12  
enable, C-13  
fill, C-14  
go, C-15  
help, C-15  
init, C-16  
printenv, C-16  
setenv, C-20  
test, C-20  
unsetenv, C-21  
Contrast control, 1-10, 6-10  
Cursor, 6-16

## D

d (deposit) command, C-9  
Degauss button, 1-10, 6-10  
Diagnostic indicator lights, 1-3  
disable command, C-10  
dump command, C-10

## E

- e (examine) command, C-12
- enable command, C-13
- Environment variables, C-17
- Equipment specifications
  - hard disk drive (RZ23), A-23 to A-24
  - hard disk drive (RZ55), A-18 to A-19
  - keyboard (LK201), A-14 to A-15
  - monitor (VR150), A-3 to A-5
  - monitor (VR160), A-6 to A-7
  - monitor (VR262), A-8
  - monitor (VR299), A-11 to A-13
  - mouse (VSXXX-AA), A-16 to A-17
  - optical compact disc drive (RRD40), A-22
  - system unit, A-2
  - tape drive (TK50Z), A-20 to A-21

## Ethernet

- button, 1-3, 6-6, 6-8, 6-16
- station address, 3-6

## ThickWire

- connector, 1-3, 6-6, 6-16
- indicator light, 1-3, 6-6, 6-16
- terminator, 6-5
- troubleshooting, 6-6, 6-16

## ThinWire

- connector, 1-3, 6-8, 6-16
- indicator light, 1-3, 6-8, 6-16
- T-connector, 6-8, 6-16
- terminator, 6-7, 6-13
- troubleshooting, 6-8, 6-16

## Expansion box, 2-2, 5-1

- cable, 6-16
- terminator, 6-14, 6-15
- turning off, 3-5
- turning on, 3-3

## External devices

See Storage, external devices

## F

- fill command, C-14

- Fuse (monitor), 1-10

## G

- go command, C-15

## H

### Hardware options

See Options

### Hardware problems

See Troubleshooting

- help command, 3-8, C-15
- Hold Screen key, 6-16

## I

### Icons

- monitor, 1-5
- system unit, 1-3, 1-4
- init command, 3-8, C-16

## K

### Keyboard, 1-1, 1-12

- adjusting, 1-12
- components, 1-12
- connector, 1-3, 6-3
- troubleshooting, 6-3, 6-16
- using, 1-12

## L

### LED self-test results

interpreting, D-3

## M

### Memory

- adding, 2-1
- installing, 2-1

### Modem

- adding, 2-4
- connector, 1-3, 6-16
- installing, 2-4
- troubleshooting, 6-16

## Modem (cont'd.)

turning off, 3-5

turning on, 3-3

Monitor, 1-1, 1-5 to 1-10, 3-6

connector, 1-10

controls, 1-10

icons, 1-5

tilt-lock/tilt-swivel, 1-10

troubleshooting, 6-10

turning off, 3-5

turning on, 3-3

using, 1-7 to 1-10

Monitor-system unit cable connector,  
1-3, 1-10

Monitor-system unit power connector,  
1-3

Mouse, 1-1, 1-13 to 1-15

cleaning, 1-14 to 1-15

connector, 1-3, 6-3

troubleshooting, 1-13, 6-3, 6-16

using, 1-13

## O

On/off switch, 1-3

Optical compact disc drive, 5-3

Operating system shutdown, 3-5

Optical compact disc drive, 5-1 to  
5-15

loading, 5-5 to 5-7

unloading, 5-8

using, 5-4 to 5-15

Options (hardware)

memory. *See* Memory

modem. *See* Modem

printer. *See* Printer

storage. *See* Storage

tape drive, *See* Tape drive

## P

Part numbers

basic components, B-1

cords, cables, and connectors, B-2

hardware, B-1 to B-2

Part numbers (cont'd.)

hardware documentation, B-3

software documentation, B-3

Power indicator light, 1-10

optical compact disc drive, 3-2, 3-3

Power-up self-test

*see* self-test

printenv command, 3-8, C-16

Printer

adding, 2-3

connector, 1-3

installing, 2-3

troubleshooting, 6-16

turning off, 3-5

turning on, 3-3

## R

Reset button, 1-3, 6-10

## S

SCSI connector, 1-3

SCSI devices

*See* Storage, external devices

SCSI switches optical compact disc  
drive, 5-3

Self-test, 3-2 to 3-8

codes, D-2

display, 3-2 to 3-4

failure of, 3-2 to 3-4, 6-3 to 6-8

interpreting, D-1 to D-3

status LED display codes, D-3

subtest 1, 6-8

subtest 2, 6-5 to 6-8

subtest 3, 6-4

subtest 4/5/6/7, 6-4

using, 3-2 to 3-4, 6-2 to 6-3

setenv command, C-20

Shutting down the operating system  
commands, 3-10

Storage

adding, 2-2

external devices, 2-2, 3-6, 3-7, 6-16

tape drive. *See* Tape drive

## Storage (cont'd.)

- installing, 2-2
- internal devices, 2-2, 3-6
- troubleshooting.

*See* Troubleshooting

- System unit, 1-1, 1-2 to 1-3
  - connectors, 1-2 to 1-3
  - controls, 1-2 to 1-3
  - expansion cable, 6-16
  - icons, 1-2, 1-4
  - indicator lights, 1-2 to 1-3
  - power connector, 1-3
  - turning off, 3-5
  - turning on, 3-3

## T

### Tape drive, 3-7

- labeling a tape, 4-15
- loading a tape, 4-7
- removing a tape, 4-12
- using, 4-1 to 4-12
- write-enabling a tape, 4-5
- write-protecting a tape, 4-4

### T-connector (Ethernet), 6-5, 6-8

- test -a command, 3-8, 6-3
- test -c command, 3-6, 3-8
- test command, C-20

### ThickWire Ethernet

*See* Ethernet, ThickWire

### ThinWire Ethernet

*See* Ethernet, ThinWire

### Tilt-lock/tilt-swivel

*See* Monitor, tilt-lock/tilt-swivel

### Troubleshooting

- contacting Digital service, 6-17
- external storage devices, 6-16
- keyboard, 6-3, 6-16
- modem, 6-16
- monitor, 6-10, 6-16
- mouse, 1-13, 6-3, 6-16
- printer, 6-16
- standalone workstation, 6-5
- system unit, 3-2 to 3-4, 6-16

## Troubleshooting (cont'd.)

- ThickWire Ethernet, 6-5, 6-6, 6-16

- ThinWire Ethernet, 6-5, 6-7, 6-16
- trs command, C-8

## U

- unsetenv command, C-21

## V

- Video cable, 1-10, 6-10

- Voltage (monitor), 1-10

- Voltage-selection switch (optical compact disc drive), 5-3

## W

### Workstation

- basic components, 1-1
- dismantling, 7-1 to 7-2
- moving, 7-1
- packing, 7-3
- reinstalling, 7-3
- troubleshooting.

*See* troubleshooting

- turning off, 3-4

- turning on, 3-2 to 3-3

# Reader's Comments

## DECstation 2100/3100 Operator's Guide

Order No: EK-302AB-OG-002

Your comments and suggestions will help us in our continuous effort to improve the quality and usefulness of our publications.

What is your general reaction to this manual?

	Excellent	Very Good	Good	Fair	Poor
Accuracy					
Completeness					
Organization					
Format					

Does the publication satisfy your needs?  Yes  No

How or How not?

---

---

What errors have you found? (Reference page number, table number, figure number.)

---

---

Please write additional comments on the back of this form.

Name \_\_\_\_\_ Title \_\_\_\_\_  
Department \_\_\_\_\_ Company \_\_\_\_\_  
Street \_\_\_\_\_ City \_\_\_\_\_  
State-Country \_\_\_\_\_ Zip \_\_\_\_\_

Return with your comments and suggestions to:

Digital Equipment Corporation  
Workstation Systems Engineering  
Documentation Department  
100 Hamilton Avenue (UCO-2)  
Palo Alto, CA 94301