

# Hard Disk System

---

## Error Guide

**digital**™

First Edition

---

The information in this document is subject to change without notice and should not be construed as a commitment by Digital Equipment Corporation. Digital Equipment Corporation assumes no responsibility for any errors that may appear in this document.


The software described in this document is furnished under a license and may only be used or copied in accordance with the terms of such license.

No responsibility is assumed for the use or reliability of software on equipment that is not supplied by DIGITAL or its affiliated companies.

The specifications and drawings, herein, are the property of Digital Equipment Corporation and shall not be reproduced or copied or used in whole or in part as the basis for the manufacture or sale of items without written permission.

Copyright © 1985 by Digital Equipment Corporation  
All Rights Reserved

The following are trademarks of Digital Equipment Corporation:

CTI BUS	MASSBUS	Rainbow
DEC	PDP	RSTS
DECmate	P/OS	RSX
DECsystem-10	PRO/BASIC	Tool Kit
DECSYSTEM-20	PRO/Communications	UNIBUS
DECUS	Professional	VAX
DECwriter	PRO/FMS	VMS
DIBOL	PRO/RMS	VT
	PROSE	Work Processor
	PROSE PLUS	

# Before You Start

---

## **Purpose of This Document**

This book is intended as a quick reference for error messages which may appear on your monitor screen during normal operation of the Professional.

## **Intended Audience**

Both the end user and the software developer will find the information in this book helpful and informative. Software developers should also refer to the PRO/Tool Kit documentation for complete error code listings for the program language they are working with.

Whether you put the system together and loaded the software or not, this book should help you to understand any problem indicated by error or status codes.

## **Required Reading**

You should be familiar with the *Professional Owner's Manual*, *Hard Disk System Documentation Set*, *Professional Installation Instructions Hard Disk Drive*, *Professional Installation Instructions Diskette Drive*, *PRO/DECnet User's Guide*, and the *Diagnostics Maintenance User's Guide* before using this book.

## Conventions Used in This Book

This book uses certain conventions to represent the way an action should be performed or the way a command should be entered from the keyboard. Following is an explanation of these conventions:

KEY	Words set in this typeface indicate a key on your LK201 keyboard. For example, RETURN, K, and 5 are keys.
< >	Angle brackets are used in examples to indicate a single keystroke. For example, <EXIT> tells you to press the EXIT key.
Press	Tells you to make one keystroke with the indicated key.
Type	Tells you to enter characters from the keyboard. For example, if you are asked to type LOGIN, you make five keystrokes: one for each letter.
Dot matrix	Indicates characters that the computer supplies to the screen, as opposed to the ones the user types.
[ ]	Square brackets enclose items that are optional, or items that are defined, either by you, or the Professional.
nn or xx	Indicate the variable digits in a specific code.

# Contents

---

## **CHAPTER 1 INTRODUCTION**

---

Information in This Book .....	3
How to Use This Guide .....	3
Chapter Summary .....	4
Basic Concepts .....	5
Error Reporting .....	8
Hardware Errors .....	8
Software Application Errors .....	8
Terminal Subsystem .....	8
Error Reporting Form .....	9

## **CHAPTER 2 HARDWARE MESSAGES**

---

Maintenance Services Diagnostics .....	13
Fatal Hardware Errors .....	13
Hardware Failures (PC300 Family) .....	14
PC300 Family LED Error Codes .....	16
PC325 and PC350 LED Error Codes .....	18
PC380 LED Error Codes .....	19
Nonfatal Errors .....	20
System Hardware Failure on Power-Up .....	20

## **CHAPTER 3            SOFTWARE MESSAGES**

---

Main Menu Messages .....	29
Application Start-Up Error Messages .....	29
System Service Start-Up Error Codes .....	31
Application Exit Messages .....	32
System Boot Procedure Error Codes .....	32
CTEX Error Messages .....	34
Login Script File Processor Messages .....	37
Primitive Error Codes .....	38
Directive Status Word (DSW) Messages .....	38
Input and Output (I/O) Error Messages .....	40
I/O Success Codes .....	42
P/OS Drivers .....	42
I/O Full-Word Subcodes for IS.SUC Return in Terminal Driver ....	42
I/O High-Byte Subcodes for IE.ABO Return in Terminal Driver ....	43
I/O Status for Communication Driver, XKDRV .....	44
I/O High-Byte Subcodes for IE.ABO Return in Communication Driver .....	44
I/O Status for Disk Drivers .....	44
FMS-11 Error Messages .....	45
RMS-11 (Record Management System) .....	46
RMSIFL Error Messages .....	46
Completion Codes .....	46

## **CHAPTER 4            TERMINAL SUBSYSTEM BUGCHECKS**

---

The Terminal Subsystem .....	49
------------------------------	----

## **APPENDIX A            HARDWARE DIAGRAMS**

---

Hardware Diagrams .....	53
-------------------------	----

## **APPENDIX B            SYSTEM INSTALLATION ERROR CODES**

---

System Installation Error Codes .....	59
---------------------------------------	----

## **APPENDIX C            OPTION ID ERROR CODES**

---

Option ID Error Codes .....	63
-----------------------------	----

---

**APPENDIX D PROTSK ERROR MESSAGES**

---

PROTSK Error Messages .....	67
-----------------------------	----

---

**APPENDIX E P/OS BUGCHECK CODES**

---

P/OS Bugcheck Codes .....	71
---------------------------	----

---

**APPENDIX F PRO/DECNET START-UP FAILURE CODES**

---

PRO/DECnet Start-Up Failure Codes .....	75
---	----

---

**APPENDIX G P/OS SERVER NETWORK ERROR CODES**

---

P/OS Server Network Error Codes .....	79
---------------------------------------	----

---

**INDEX**

---

Index .....	83
-------------	----

---

**FIGURES**

---

Figure 1-1: Sample Error Screen–Login .....	5
Figure 1-2: Sample Error Screen–Application Start-Up .....	6
Figure 1-3: Sample Error Screen–Application Exit .....	6
Figure 1-4: Professional Computer System .....	7
Figure 2-1: Self-Test Diagram Screen Example .....	20
Figure A-1: System Circuit Breaker .....	53
Figure A-2: System Unit Card Cage .....	54
Figure A-3: Back of System Unit, Position of LEDs .....	56
Figure A-4: System Unit, Showing Motherboard .....	56

---

**TABLES**

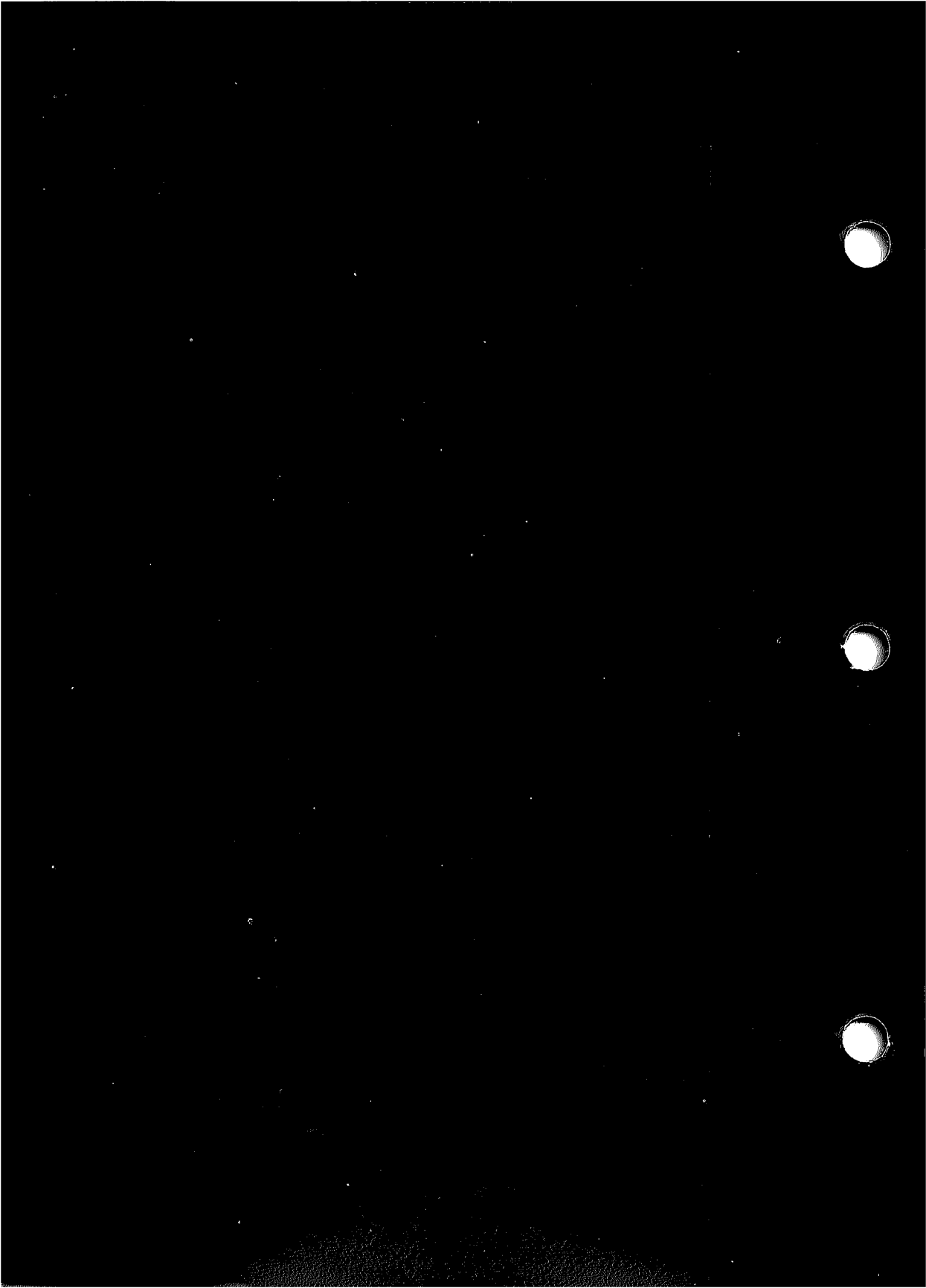
---

Table 2-1: No Response at Power-Up, PC300 Family .....	15
Table 2-2: LED Error Codes, PC300 Family .....	16
Table 2-3: LED Error Codes, PC325 and PC350 .....	18
Table 2-4: LED Error Codes, PC380 .....	19
Table 2-5: System Hardware Power-Up Error Codes .....	21

Table 3-1: Application Exit Messages .....	32
Table 3-2: Login Script File Processor Messages .....	37
Table 3-3: Directive Status Word Error Messages .....	39
Table 3-4: I/O Error Codes .....	40
Table 3-5: I/O Success Codes .....	42
Table 3-6: I/O Full-Word Subcodes .....	43
Table 3-7: I/O High-Byte Subcodes .....	43
Table 3-8: I/O Status (Communication Driver) .....	44
Table 3-9: I/O Subcodes (Communication Driver) .....	44
Table 3-10: I/O Status for Disk Drivers .....	44
Table B-1: System Installation Error Codes .....	59
Table C-1: Option ID Error Codes .....	63
Table D-1: PROTSK Error Messages .....	67
Table E-1: P/OS Bugcheck Codes .....	71
Table F-1: PRO/DECnet Start-Up Messages .....	75
Table G-1: Server Network Messages .....	80

1

Introduction



# Chapter 1

---

## Introduction

### INFORMATION IN THIS BOOK

This book is intended as a quick reference for error and status messages which may appear during normal operation of the Professional.

### HOW TO USE THIS GUIDE

Error codes and error messages appear on your monitor screen when the system cannot perform a given task. This manual lists the codes and messages that may appear on your monitor screen and presents them in the following format:

- **Code:** The letters, numbers, or words that identify the problem.
- **Explanation:** The system condition that caused the code or message to appear. Usually the explanation specifies the absence of particular data or information required to perform the task.
- **User Action:** What to do to fix the problem.

If an error code has no User Action listed, refer to the Software Application section for the proper steps to take.

Use the index to locate the Error Guide page number for the code or message that is on your monitor screen.

The codes are listed alphanumerically within each activity.

## Chapter Summary

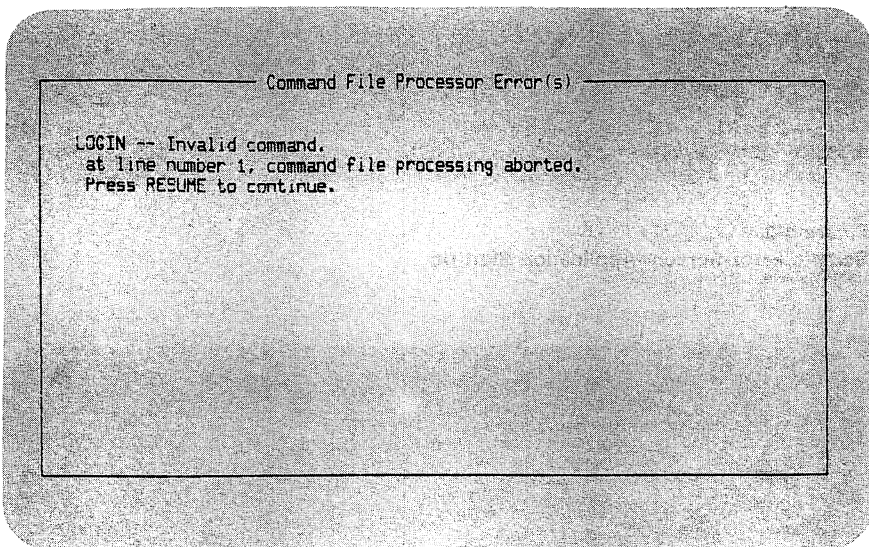
The book is divided into four chapters and seven appendices.

- Chapter 1, “Introduction,” explains the Error Guide and illustrates the configuration of the Professional. It also provides a general format for collecting and reporting error information.
- Chapter 2, “Hardware Messages,” contains hardware messages presented in table format, plus information on maintenance services diagnostics.
- Chapter 3, “Software Messages,” lists Main Menu messages, CTEX, Login, Primitive messages, and FMS-11 and RMS-11 related error messages.
- Chapter 4, “Terminal Subsystem Bugchecks,” lists the bugchecks related to this subset of the Professional.
- Appendix A has diagrams of some of the Professional’s hardware components, and their location within the system unit.
- Appendix B contains system installation error messages. These codes will appear if the system was not installed properly.
- Appendix C lists all codes related to the Professional’s options. If an option is not functioning properly, a related code appears on the monitor screen.
- Appendix D is PROTSK error messages. These messages may appear in many contexts, depending on the application error reporting mechanism.
- Appendix E contains the P/OS bugcheck codes. A bugcheck is an unrecoverable error. User Action contains specific instructions.
- Appendix F lists the PRO/DECnet start-up failure error codes. These pertain only to PRO/DECnet.
- Appendix G covers the P/OS Server network error codes. These codes are only for the internal workings of P/OS Server. They should not appear; but if they do, specific User Action is available.

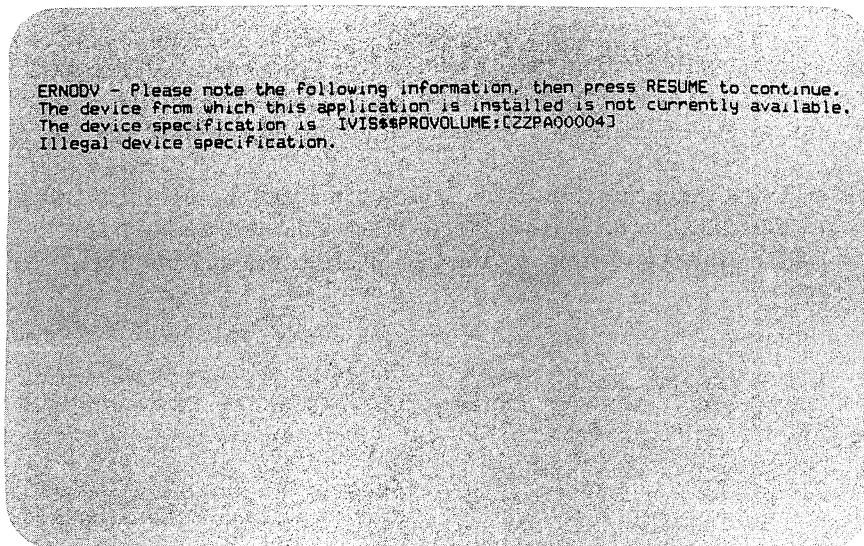
## BASIC CONCEPTS

Error codes differ both in format and in meaning. Some errors are fatal, meaning that the fault must be fixed; others are nonfatal, meaning that something is wrong but you can still run the application or the system.

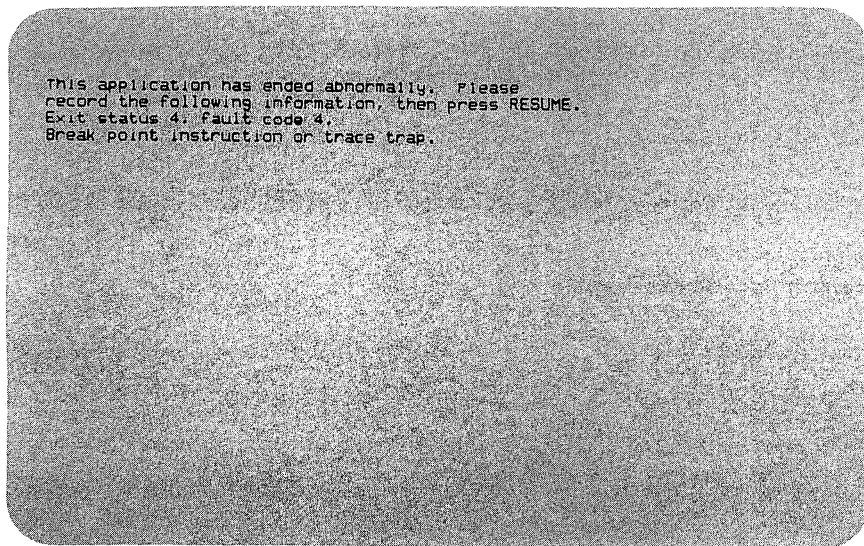
Some codes appear on the screen as shown in Figures 1-1 through 1-3; and other codes (specifically the hardware codes) are indicated by light emitting diodes, or LEDs, that are located on the back of the system unit. This is covered in Chapter 2.



**Figure 1-1**  
**Sample Error Screen—Login**

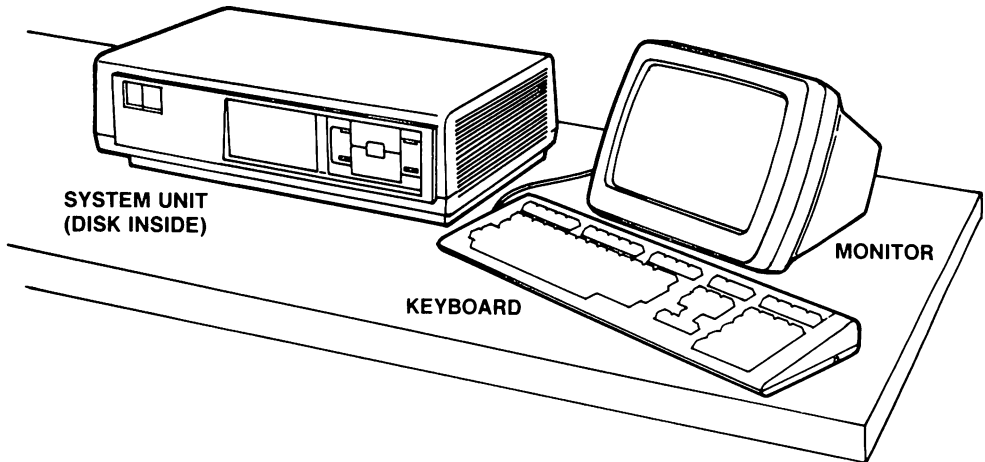


**Figure 1-2**  
**Sample Error Screen—Application Start-Up**



**Figure 1-3**  
**Sample Error Screen—Application Exit**

Figure 1-4 shows the Professional with its basic components: a system unit, a monitor, and a keyboard. The hardware section of the book uses these terms to identify where errors occur. The word *terminal* refers to both the monitor and the keyboard together.



**Figure 1-4**  
**Professional Computer System**

## **ERROR REPORTING**

As Figures 1-1 through 1-3 illustrate, errors are presented in different ways. The following sections discuss the three types of errors presented in this guide and how to correct or report them.

### **Hardware Errors**

These errors are listed in the tables in Chapter 2. Each error requires a series of steps to correct it. When hardware error problems are too complex to resolve on your own, call your DIGITAL Field Service representative. If you purchased your hardware from an OEM, call your OEM sales representative.

### **Software Application Errors**

Most software errors require the same steps for correcting or reporting. These steps are:

1. Copy down everything on the screen.
2. Verify that you have current backups of your system and important files. See the instructions for back up in the *Hard Disk System User's Guide*.
3. Reboot the system.
4. Reinstall the application.
5. If the code still appears, call your local Customer Support Center.

The service representative will need to know some information about your system and what you were doing at the time the error occurred. Use the Error Reporting Form on the next page to collect this information before you call.

### **Terminal Subsystem**

These errors have specific steps to take to correct or report them. These steps are listed in Chapter 4 under each specific error code.

## ERROR REPORTING FORM

1. **The screen shows:** \_\_\_\_\_

2. **Describe the event(s) that led to the error** — for example, booting the system, or machine was idle, or running an application, or performing a background system task such as a file transfer.

3. **System Configuration** Version No.: \_\_\_\_\_  
Operating System \_\_\_\_\_  
Terminal Setup characteristics\*: \_\_\_\_\_  
Stand-Alone System or Workstation? \_\_\_\_\_  
Application Software\*: \_\_\_\_\_ Version No.\*: \_\_\_\_\_  
PRO/Tool Kit Version No.\*: \_\_\_\_\_ Language\*: \_\_\_\_\_

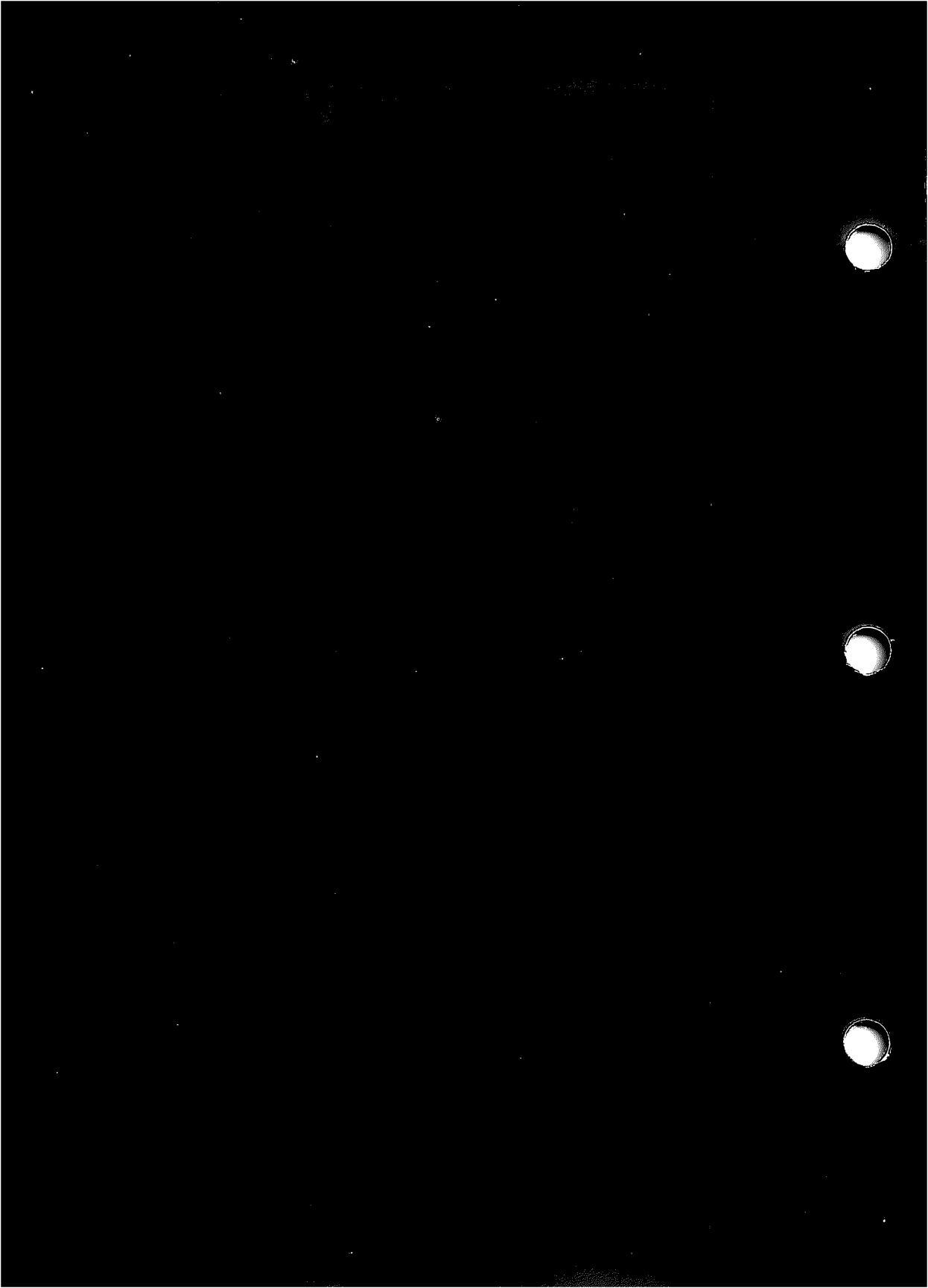
4. **If you are using Communications:**  
PRO/Communications Version No.: \_\_\_\_\_  
PRO/Communications Setup Characteristics  
Connection Type (Hardwired; Modem; Mini-Exchange): \_\_\_\_\_  
Line Speeds: \_\_\_\_\_  
Other device(s) connected to the line: \_\_\_\_\_  
PRO/DECnet Version No.\*: \_\_\_\_\_  
Host Communications Version No.\*: \_\_\_\_\_  
Host Configuration\*: \_\_\_\_\_

\* Provide if applicable.

2

---

Hardware Messages



## Chapter 2

---

### Hardware Messages

This chapter contains fatal, nonfatal, and maintenance services diagnostic messages. LED (light emitting diodes) tables and complete PC300 family hardware code tables complete this chapter.

#### **MAINTENANCE SERVICES DIAGNOSTICS**

Your Professional system comes with a maintenance diskette package. This maintenance application package contains a complete set of test programs. You can run the diskettes as an application on the diskette-based operating system.

When you encounter a Maintenance Services Diagnostic message, your Professional instructs you how to obtain additional information regarding this message. Follow the instructions displayed on your monitor screen.

The following is an example of a Maintenance Services Diagnostic message:

```
The system interrupts are not functioning properly.  
Consult the owner's manual.
```

#### **FATAL HARDWARE ERRORS**

“Fatal” means that you get limited response or no response from the system unit when the system is powered up. The causes could be anything from no electricity in the wall outlet to an improperly connected cable or bad module board. The following tables describe each possible situation and list corrective action steps. (“Nonfatal” hardware errors are in a separate section in this chapter.)

### Hardware Failures (PC300 Family)

If there is no response on your monitor screen after you switch ON the Professional and its monitor, restart the system by turning the system power switch OFF and ON. If the problem persists, look at the light emitting diodes (LEDs) on the back of the system unit to identify the problem. The pattern of lights that are lit corresponds to the "LEDs" column in Table 2-2. Use the Corrective Action column to fix the problem. If you do not have the necessary spare parts available or if the corrective action seems too complex, call your DIGITAL Field Service representative, or OEM sales representative.

Note that there are three sets of LED tables: one for the PC300 family, one for the PC325 and PC350, and one for the PC380. Refer to the proper table for your system.

If you need assistance, follow the instructions in your service contract. If you do not have a service contract, contact your local Customer Support Center for information on how to obtain time or materials services.

**Table 2-1**  
**No Response at Power-Up, PC300 Family<sup>1</sup>**

<i>Symptom</i>	<i>Additional Checks</i>	<i>Corrective Action</i>
No response when power switch is turned ON	Check power cord connection to system and wall outlet.	Reconnect power cord to system and wall outlet.
	Circuit breaker tripped.	Reset circuit breaker by pushing it in.
	No power at wall outlet.	Call an electrician.
No response when power switch is turned ON, but fan is running	Power cord shorted or opened.	Check power cord for continuity, and replace it if necessary. Check power cable connection from power supply to system unit.
	Green LED on back of system unit is OFF.	Check power cable connection from power supply to system unit. Replace system power supply.
	Green LED is ON and four red LEDs are OFF.	Check monitor cable connections and adjust monitor controls. Reseat system daughter boards, if present. Replace monitor.
	Green LED is ON and any or all of red LEDs are ON.	System has failed. Refer to LED Tables in this chapter for the error and corrective action.

<sup>1</sup>Refer to Appendix A for Professional hardware diagrams.

### PC300 Family LED Error Codes

The LED's are labeled 4 3 2 1, starting from the left as you face the back of the system unit.

**Table 2-2**  
**LED Error Codes, PC300 Family<sup>1</sup>**

LEDs*				Error	Corrective Action
4	3	2	1		
○	○	○	○	None (test passed)	<ol style="list-style-type: none"> <li>1. Adjust contrast and brightness controls on monitor.</li> <li>2. Check video cable connections at monitor.</li> <li>3. Replace monitor.</li> <li>4. Replace motherboard.</li> </ol>
○	○	○	⊙	I/O Failure in slot 1	<ol style="list-style-type: none"> <li>1. Check all cables connected to I/O board slot 1.</li> <li>2. Reseat I/O board in slot 1.</li> <li>3. Replace I/O board in slot 1.</li> <li>4. Replace device connected to I/O board in slot 1.</li> </ol>
○	○	⊙	○	I/O Failure in slot 2	<ol style="list-style-type: none"> <li>1. Check all cables connected to I/O board in slot 2.</li> <li>2. Reseat I/O board in slot 2.</li> <li>3. Replace I/O board in slot 2.</li> <li>4. Replace device connected to I/O board in slot 2.</li> </ol>
○	○	⊙	⊙	I/O Failure in slot 3	<ol style="list-style-type: none"> <li>1. Check all cables connected to I/O board in slot 3.</li> <li>2. Reseat I/O board in slot 3.</li> <li>3. Replace I/O board in slot 3.</li> <li>4. Replace device connected to I/O board in slot 3.</li> </ol>
○	⊙	○	○	I/O Failure in slot 4	<ol style="list-style-type: none"> <li>1. Check all cables connected to I/O board in slot 4.</li> <li>2. Reseat I/O board in slot 4.</li> <li>3. Replace I/O board in slot 4.</li> <li>4. Replace device connected to I/O board in slot 4.</li> </ol>
○	⊙	○	⊙	I/O Failure in slot 5	<ol style="list-style-type: none"> <li>1. Check all cables connected to I/O board in slot 5.</li> <li>2. Reseat I/O board in slot 5.</li> <li>3. Replace I/O board in slot 5.</li> <li>4. Replace device connected to I/O board in slot 5.</li> </ol>
○	⊙	⊙	○	I/O Failure in slot 6	<ol style="list-style-type: none"> <li>1. Check all cables connected to I/O board in slot 6.</li> <li>2. Reseat I/O board in slot 6.</li> <li>3. Replace I/O board in slot 6.</li> <li>4. Replace device connected to I/O board in slot 6.</li> </ol>

\* A ⊙ means that the indicator is ON.

<sup>1</sup>Refer to Appendix A for Professional hardware diagrams.

**Table 2-2**  
**LED Error Codes, PC300 Family (Cont.)<sup>1</sup>**

<i>LEDs*</i>				<i>Error</i>	<i>Corrective Action</i>
<i>4</i>	<i>3</i>	<i>2</i>	<i>1</i>		
○	●	●	●	System Module Failure	<ol style="list-style-type: none"> <li>1. Restart system by turning system power switch OFF and ON.</li> <li>2. If error disappears, run system unit test on maintenance application diskette.</li> <li>3. If error remains, replace motherboard.</li> </ol>
●	○	○	○	System Module Failure	<ol style="list-style-type: none"> <li>1. Restart system by turning system power switch OFF and ON.</li> <li>2. If error disappears, run system unit test on maintenance application diskette.</li> <li>3. If error remains, replace motherboard.</li> </ol>
●	○	○	●	Keyboard Interface Failure	<ol style="list-style-type: none"> <li>1. Check keyboard cable and connections at keyboard and monitor.</li> <li>2. Check video cable at monitor and system unit. Right angle end of cable should be connected to video monitor.</li> <li>3. Replace keyboard.</li> <li>4. Replace monitor.</li> <li>5. Replace system board.</li> </ol>
●	○	●	○	No Boot Device Found	<ol style="list-style-type: none"> <li>1. Reboot from P/OS system diskette.</li> <li>2. If reboot is good, check RD hard disk subsystem.</li> <li>3. If still no boot, check for bad diskette.</li> <li>4. Check cables on RX50 and RD hard disk subsystems from the controllers to their drives, and reseat RX and/or RD controller board.</li> <li>5. Replace RX and/or RD controller board.</li> <li>6. Replace RX and/or RD drive.</li> <li>7. Replace motherboard.</li> </ol>
●	○	●	●	Monitor Not Present	<ol style="list-style-type: none"> <li>1. Check video cable and connections at monitor and system unit. Right angle end of cable should be connected to video monitor.</li> <li>2. Replace monitor.</li> <li>3. Replace motherboard.</li> </ol>

**NOTE:** A workstation must be properly registered with a file server before the file server may accept the boot request. Have the File Server system manager verify that your Ethernet hardware address is correct by running the Workstation Registration Application on the P/OS Server.

\* A ● means that the indicator is ON.

<sup>1</sup>Refer to Appendix A for Professional hardware diagrams.

**PC325 and PC350 LED Error Codes**

**Table 2-3**  
**LED Error Codes, PC325 and PC350<sup>1</sup>**

<i>LEDs*</i>				<i>Error</i>	<i>Corrective Action</i>
<i>4</i>	<i>3</i>	<i>2</i>	<i>1</i>		
⊗	⊗	○	○	System Memory Failure	<ol style="list-style-type: none"> <li>1. Restart system by turning system power switch OFF and ON.</li> <li>2. If error disappears, run system unit test on maintenance application diskette.</li> <li>3. If error remains, replace motherboard.</li> <li>4. If error still remains, replace both memory daughter modules.</li> </ol>
⊗	⊗	○	⊗	System Memory Failure (Bank 1)	<ol style="list-style-type: none"> <li>1. Restart system by turning system power switch OFF and ON.</li> <li>2. If error disappears, run system unit test on maintenance application diskette.</li> <li>3. If error remains, replace bank 1 memory board.</li> </ol>
⊗	⊗	⊗	○	System Memory Failure (Bank 0)	<ol style="list-style-type: none"> <li>1. Restart system by turning system power switch OFF and ON.</li> <li>2. If error disappears, run system unit test on maintenance application diskette.</li> <li>3. If error remains, replace bank 0 memory board.</li> </ol>
⊗	⊗	⊗	⊗	System Module Failure	<ol style="list-style-type: none"> <li>1. Restart system by turning system power switch OFF and ON.</li> <li>2. If error remains, replace bank 0 memory board.</li> <li>3. If error remains, replace memory module (in card cage).</li> <li>4. If error remains, replace motherboard.</li> <li>5. If error still remains, remove option boards one at a time until error changes. Replace last board removed when error changes.</li> </ol>

\*A⊗ means that the indicator is ON.

<sup>1</sup>Refer to Appendix A for Professional hardware diagrams.

**PC380 LED Error Codes**

**Table 2-4**  
**LED Error Codes, PC380<sup>1</sup>**

<i>LEDs*</i>				<i>Error</i>	<i>Corrective Action</i>
<i>4</i>	<i>3</i>	<i>2</i>	<i>1</i>		
●	●	○	○	System Module Memory Failure	<ol style="list-style-type: none"> <li>1. Restart system by turning system power switch OFF and ON.</li> <li>2. If error disappears, run system unit test on maintenance application diskette.</li> <li>3. If error remains, replace motherboard.</li> </ol>
●	●	○	●	Extended Bit Map (EBO) Daughter Board Failure	<ol style="list-style-type: none"> <li>1. Restart system by turning system power switch OFF and ON.</li> <li>2. If error disappears, run system unit test on maintenance application diskette.</li> <li>3. If error remains, replace EBO daughter card.</li> <li>4. If error remains, replace motherboard.</li> </ol>
●	●	●	○	Memory Daughter Board Failure	<ol style="list-style-type: none"> <li>1. Restart system by turning system power switch OFF and ON.</li> <li>2. If error disappears, run system unit test on maintenance application diskette.</li> <li>3. If error remains, replace memory daughter card.</li> <li>4. If error remains, replace motherboard.</li> </ol>
●	●	●	●	System Module Failure	<ol style="list-style-type: none"> <li>1. Restart system by turning system power switch OFF and ON.</li> <li>2. If error remains, replace memory daughter board, if present.</li> <li>3. If error remains, replace motherboard.</li> <li>4. If error still remains, remove option boards one at a time until error changes. Replace last board removed when error changes.</li> </ol>

\*A ● means that the indicator is ON.

<sup>1</sup>Refer to Appendix A for Professional hardware diagrams.

### NONFATAL ERRORS

“Nonfatal” means that the system booted properly but found a problem. Usually the problem is not difficult to correct. The keyboard might have to be replaced, or a particular module board replaced or reseated. If you need to replace a part and do not have that part available, call your DIGITAL Field Service representative, or OEM sales representative.

#### System Hardware Failure on Power-Up

Figure 2-1 shows the display that appears on your monitor screen when the system power-up self-test finds a problem. To troubleshoot the problem, find the identification (ID) number and error code in the message (see insert for location of these numbers). Table 2-5 lists each ID number, the error codes for that ID, and the corrective action to take.

Table 2-5 applies to all versions of the Professional 300 Family (PC325, PC350, PC380) for nonfatal system hardware failures at power-up. Refer to the hardware illustrations in Appendix A to determine the location of components mentioned in the table.

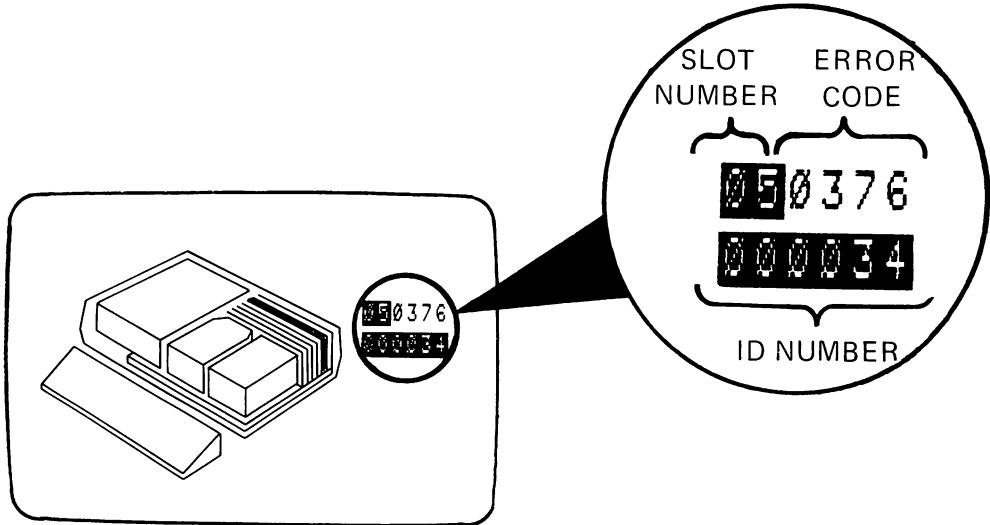


Figure 2-1  
Self-Test Diagram Screen Example

**Table 2-5**  
**System Hardware Power-Up Codes<sup>1</sup>**

<b>ID Number</b>	<b>Error Code</b>	<b>Problem Area</b>	<b>Corrective Action</b>
Any ID	0374	Slot shown on screen	<ol style="list-style-type: none"> <li>1. Reseat board in slot shown on screen.</li> <li>2. Replace board in slot shown on screen.</li> <li>3. Replace motherboard.</li> </ol>
Any ID	0376	Slot shown on screen	Replace board in slot shown on screen.
00001	0060	Keyboard	Replace keyboard.
00001	0075	Keyboard	<ol style="list-style-type: none"> <li>1. Try to free stuck key.</li> <li>2. Run keyboard key test.</li> <li>3. Replace keyboard.</li> </ol>
00001	0076	Keyboard	Replace keyboard.
000014	Any code	Keyboard port	Replace motherboard.
000017	Any code	Printer port	Replace motherboard.
000021	Any code	Communications port	Replace motherboard.
000023	Any code	Time of day Clock	Replace motherboard.
000024	Any code	Nonvolatile RAM	Replace motherboard.
000025	Any code	Interrupts	<ol style="list-style-type: none"> <li>1. Disconnect any devices from COMM1 and PR1 connectors.</li> <li>2. Switch power OFF and back ON. If failure goes away, problem is with an attached device. If failure remains, go to Step 3.</li> <li>3. Remove all options.</li> <li>4. Switch power OFF and back ON.</li> <li>5. If it fails again, replace motherboard.</li> <li>6. If failure goes away, install each option one at a time until symptom reappears. Replace last board inserted.</li> </ol>
000034	0002	Memory module (in card cage)	Memory exceeds 3 megabytes. Remove memory modules until no error appears.
000034	Any code	Memory module (in card cage)	Replace board in slot shown on screen.

<sup>1</sup>Refer to Appendix A for Professional hardware diagrams.

**Table 2-5**  
**System Hardware Power-Up Codes (Cont.)<sup>1</sup>**

<b>ID Number</b>	<b>Error Code</b>	<b>Problem Area</b>	<b>Corrective Action</b>
000041	021	Missing TLI board	Check that the Telephone Line Interface board is correctly installed in back of your Professional.
000042	0110 or less	DECNA module	1. Replace DECNA module. 2. Replace motherboard.
000042	0111 or more	Output drivers of DECNA module or external to PRO box	1. Check that the cable from the DECNA option board to the Ethernet wall connector is attached correctly. 2. Test network hardware. (Refer to <i>Installation/Owner's Manual DECNA Controller</i> ).
000043	Any code	CP/M module	Replace board in slot shown on screen.
000046	0001	Real-time interface (RTI)—serial line unit 1	1. Reseat cables and board in slot 6. 2. Replace module in slot 6.
<p><b>CAUTION:</b> Turn OFF all devices attached to RTI cables before turning system ON again.</p>			
000046	0002	RTI—serial line unit 2	1. Reseat cables and board in slot 6. 2. Replace module in slot 6.
000046	0003	RTI—parallel I/O	1. Reseat cables and board in slot 6. 2. Replace module in slot 6.
000046	0004	RTI—IEEE port	1. Reseat cables and board in slot 6. 2. Replace module in slot 6.
000046	0005	RTI—interrupt logic	1. Reseat cables and board in slot 6. 2. Replace module in slot 6.
000050	0002 thru 0007	PC380 base video failure	Replace motherboard.
000050	0103	PC380 EBO	1. Replace Extended Bitmap Option daughter module. 2. Replace motherboard.
000050 000050	0106 0107	Plane 2 failure	1. Replace EBO daughter module. 2. Replace motherboard.

<sup>1</sup>Refer to Appendix A for Professional hardware diagrams.

**Table 2-5**  
**System Hardware Power-Up Codes (Cont.)<sup>1</sup>**

<i>ID Number</i>	<i>Error Code</i>	<i>Problem Area</i>	<i>Corrective Action</i>
000050	0203	PC380 EBO	<ol style="list-style-type: none"> <li>1. Replace EBO daughter module.</li> <li>2. Replace motherboard.</li> </ol>
000050 000050	0206 0207	Plane 3 failure	<ol style="list-style-type: none"> <li>1. Replace EBO daughter module.</li> <li>2. Replace motherboard.</li> </ol>
000401	Any Code	Hard Disk Subsystem	<ol style="list-style-type: none"> <li>1. Check cables.</li> <li>2. Replace board in slot shown on screen.</li> <li>3. Replace RD hard disk drive. Verify that either the read/write board or complete disk drive failed.</li> </ol>
000401 000401 000401 000401	0013 0030 0031 0032	RD hard disk drive format failure	<ol style="list-style-type: none"> <li>1. During system installation, press RESUME. System instruction corrects the error.</li> <li>2. Check cables.</li> <li>3. Reformat the RD hard disk drive.</li> <li>4. Replace RD hard disk drive.</li> </ol>
000401	0374	System	<ol style="list-style-type: none"> <li>1. Replace board in slot shown on screen.</li> <li>2. Replace motherboard.</li> </ol>
001002	Any code	Basic video (in card cage)	<ol style="list-style-type: none"> <li>1. Replace board in slot shown on screen.</li> </ol>
001002	0374	System	<ol style="list-style-type: none"> <li>1. Replace board in slot shown on screen.</li> <li>2. Replace motherboard.</li> </ol>
001403	Any code	Extended bit map (in card cage)	<ol style="list-style-type: none"> <li>1. Check cable between basic video and extended bit map boards.</li> <li>2. Replace board in slot shown on screen.</li> </ol>
001403	0374	System	<ol style="list-style-type: none"> <li>1. Replace board in slot shown on screen.</li> <li>2. Replace motherboard.</li> </ol>
002004 002004 002004 002004 002004 002004 002004 002004	0001 0002 0003 0210 0220 0300 0310 0360 0370	RX subsystem	<ol style="list-style-type: none"> <li>1. Remove the cover from the Professional and check the cable connecting the diskette drive to the connector option board.</li> <li>2. Replace board in slot shown on screen.</li> <li>3. Replace RX drive.</li> </ol>

<sup>1</sup>Refer to Appendix A for Professional hardware diagrams.

**Table 2-5**  
**System Hardware Power-Up Codes (Cont.)<sup>1</sup>**

<i>ID Number</i>	<i>Error Code</i>	<i>Problem Area</i>	<i>Corrective Action</i>		
002004	0010	RX subsystem	<ol style="list-style-type: none"> <li>1. Insert initialized diskette correctly in the drive.</li> <li>2. Check RX drive cables.</li> <li>3. Replace RX drive.</li> <li>4. Replace board in slot shown on screen.</li> </ol>		
002004	0020				
002004	0030				
002004	0040				
002004	0050				
002004	0060				
002004	0070				
002004	0100				
002004	0110				
002004	0120				
002004	0130				
002004	0140				
002004	0150				
002004	0160			RX subsystem	<ol style="list-style-type: none"> <li>1. Insert initialized diskette.</li> <li>2. Check RX drive cables.</li> <li>3. Replace RX drive.</li> <li>4. Replace board in slot shown on screen.</li> </ol>
002004	0170				
002004	0200				
002004	0220				
002004	0230				
002004	0240				
002004	0250				
002004	2060				
002004	0270				
002004	0320				
002004	0330				
002004	0340				
002004	0350				
002004	0374	System	<ol style="list-style-type: none"> <li>1. Replace board in slot shown on screen.</li> <li>2. Replace motherboard.</li> </ol>		
10050, 20050, 30050	0002 0002 0002 0007	PC380 base video failure	<ol style="list-style-type: none"> <li>1. Replace motherboard.</li> <li>2. Replace EBO daughter module.</li> </ol>		
10050, 20050, 30050	0103 0106 0107	PC380 EBO Plane 2 failure	<ol style="list-style-type: none"> <li>1. Replace EBO daughter module.</li> <li>2. Replace motherboard.</li> </ol>		
10050, 20050, 30050	0203 0206 0207	PC380 EBO Plane 3 failure	<ol style="list-style-type: none"> <li>1. Replace EBO daughter module.</li> <li>2. Replace motherboard.</li> </ol>		

<sup>1</sup>Refer to Appendix A for Professional hardware diagrams.

**Table 2-5**  
**System Hardware Power-Up Codes (Cont.)<sup>1</sup>**

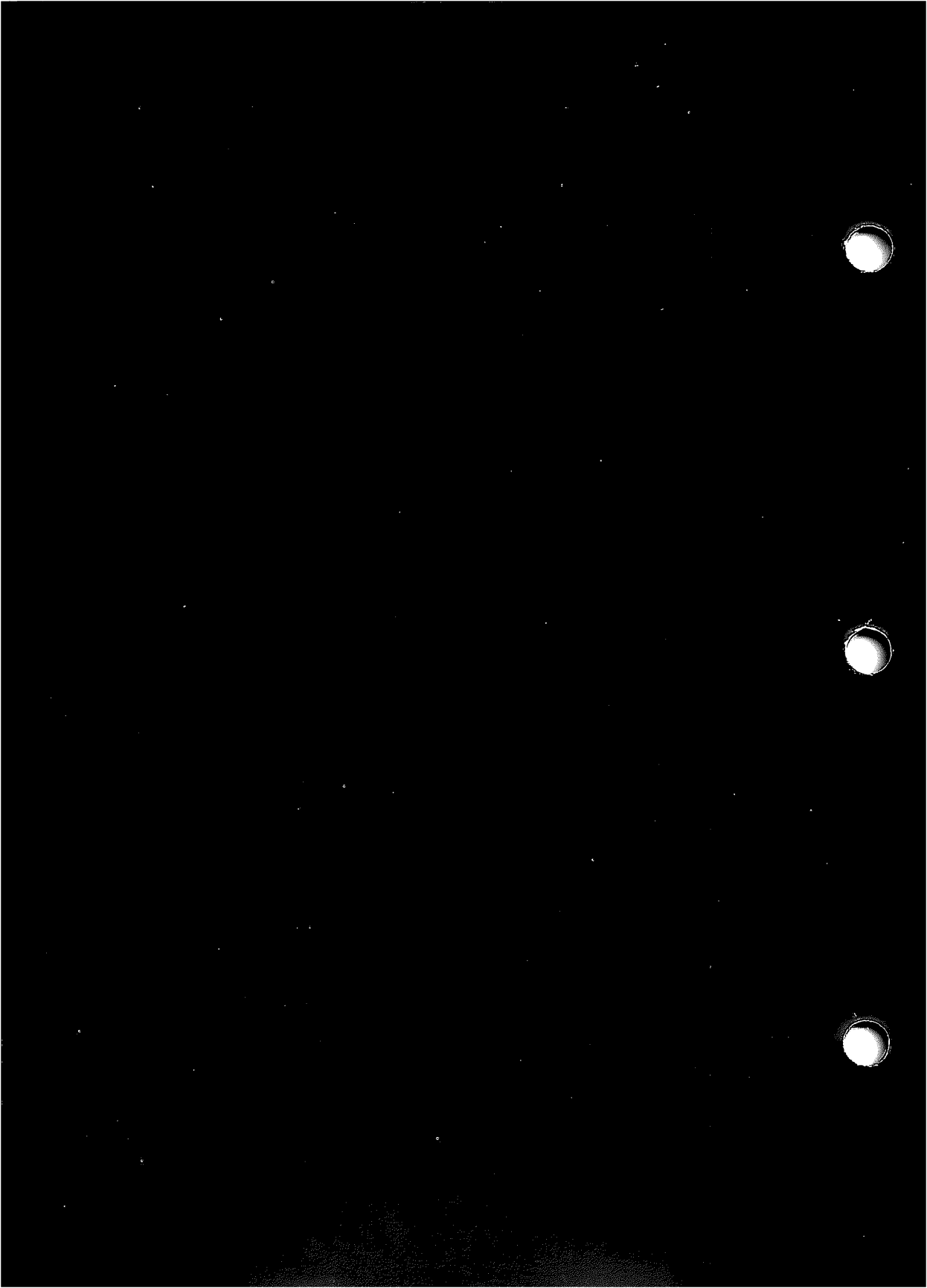
<i>ID Number</i>	<i>Error Code</i>	<i>Problem Area</i>	<i>Corrective Action</i>
3006	203	Error for IVIS	Make sure the cable from the IVIS system option board to the IVIS external box is connected correctly.
3006	204	Error printed after IVIS system error	Make sure the cable from the IVIS system option board to the IVIS external box is attached correctly.
077776	Any Code	Unidentified Device Error	<ol style="list-style-type: none"> <li>1. Reboot the system.</li> <li>2. If error still occurs, call your DIGITAL Field Service representative, or OEM sales representative.</li> </ol>
177776 177776	0375 0376	System	<ol style="list-style-type: none"> <li>1. Check internal cables.</li> <li>2. Replace board in slot shown on screen.</li> <li>3. Replace any device connected to that board.</li> </ol>
177776	0377	System	<ol style="list-style-type: none"> <li>1. Check cables.</li> <li>2. Replace board in slot shown on screen.</li> <li>3. Replace any device connected to that board.</li> <li>4. Replace motherboard.</li> </ol>

<sup>1</sup>Refer to Appendix A for Professional hardware diagrams.

3

---

Software Messages



## Chapter 3

---

### Software Messages

The software error messages contained in this chapter are:

- Application Start-Up
- Install/Run/Remove
- Application Exit
- System Boot Procedure
- CTEX
- Login
- Directive Status Word
- Input/Output (I/O)
- FMS-11
- RMS-11

#### **MAIN MENU MESSAGES**

##### **Application Start-Up Error Messages**

These error messages may appear during the start-up of an application.

An example of an application start-up error is:

```
ERNODV - Please note the following information, then press RESUME to continue.  
The device from which this application is installed is not currently available.  
The device specification is  IVIS**PROVOLUME:[ZZPA00004]  
Illegal device specification.
```

The User Action for these messages is to:

1. Copy down the information on the screen and press **RESUME**.
2. Try to run the application again. See if the error can be reproduced.
3. Logout from the Professional and log in again.
4. Try to run the same application. See if the error can be reproduced.
5. Reboot the system and try to run the same application. See if the error can be reproduced.
6. Reinstall the application. See if the error can be reproduced.
7. If the error message still appears, call the company from whom you purchased the application.

**Message:** ERHDN2—Error occurred in parsing of shared /NETWORK area specification. The application script file is [script\_file].

**Message:** ERHDN3—Error occurred in creating concealed logical for /NETWORK components. The application script file is [script\_file].

**Message:** ERNODV—The device from which this application is installed is not currently available. The device specification is [device\_name]. Illegal device specification.

**Reminder:** Make sure the device you want to use is available. Also, make sure you are logged onto the fileserver.

**Message:** ERRFND—Error occurred while locating an application component from the .INS/.INB file. The application script file is [script\_file]. The command line is the [command\_line] causing the error. Looking for file [filename].

**Message:** ERRFUL—The number of INSTALL commands cannot exceed the maximum limit. The application script file is [script\_file]. The current command line is the [command\_line] causing the error.

**Message:** ERRGET—Error occurred while reading a command line from the .INS/.INB file. The application script file is [script\_file]. The last command was the [command] issued.

**Message:** ERRHDN—Error occurred creating the APPL\$NETWORK: logical. The application script file is [script\_file]. The command line is the [command\_line] causing the error.

**Message:** ERRINS—Error occurred in installing tasks (or regions/libraries). The application script file is [script\_file], task [task\_name].

**Message:** ERRLOG—Error occurred in processing ASSIGN command from the .INS/.INB file. The application script file is [script\_file]. The command line is the [command\_line] causing the error.

**Message:** ERRMCR—Error occurred in getting a command line. The command is the [command\_line] causing the error.

**Message:** ERRMPR—Error occurred during RMS parse operation. The application script file is [script\_file]. The command line is the [command\_line] causing the error. Looking for file: [filename].

**Message:** ERROPN—Error occurred in accessing the application .INS/.INB file. The application script file is [script\_file].

**Message:** ERRPOI—Error occurred in starting an application task. The application script file is [script\_file], task [task\_name].

**Message:** ERRPRS—Error occurred while parsing the command line from the .INS/.INB file. The application script file is [script\_file]. The command line is the [command\_line] causing the error.

**Explanation:** The ^ character identifies the place in the command line where the error occurred.

**Message:** ERRPRV—Error occurred in creating logical for the user private components. The application script file is [script\_file]. The current line is the [current\_line] issued.

### System Service Start-Up Error Codes

This error message displays if an error occurs during the start-up of the application dispatcher task.

**Message:** The application dispatcher task could not be started because of an error. Please record the following error information, then press RESUME. Spawn DSW error [line\_number].

The POSSUM service used to start system services such as file-disk, print control, or view message, displays this message when reporting an INSTALL/RUN/REMOVE error.

**Message:** An error has occurred in the POSSUM Install/Run/Remove service. Note down ALL the following information, and press RESUME.

- 8 decimal words
- File = [filename], Task = [taskname]

## Application Exit Messages

Application exit messages may appear when you are running an application. If one of these messages appears on the screen, follow the User Action instructions in the Application Start-Up Error Codes section of this chapter. If you need help with software purchased through DIGITAL, refer to your DIGITAL contract or service agreement for the telephone number to call.

The following example illustrates an Application Exit Message:

```
This application has ended abnormally. Please
record the following information, then press RESUME.
Exit status 4, fault code 4.
Break point instruction or trace trap.
```

Table 3-1 lists the Application Exit Messages.

**Table 3-1**  
**Application Exit Messages**

<i>Code</i>	<i>Explanation</i>
Exit status 4. Fault code -2.	Task requested abort
Exit status 4. Fault code 0.	Odd address and other traps to 4
Exit status 4. Fault code 2.	Memory protect violation
Exit status 4. Fault code 4.	Break point instruction or trace trap
Exit status 4. Fault code 6.	IOT instruction
Exit status 4. Fault code 8.	Illegal or reserved instruction
Exit status 4. Fault code 10.	Non-RSX EMT instruction
Exit status 4. Fault code 12.	Trap instruction
Exit status 4. Fault code 16.	SST abort—bad stack
Exit status 4. Fault code 18.	AST abort—bad stack
Exit status 4. Fault code 20.	Abort via directive (ABRT\$)
Exit status 4. Fault code 22.	Task load read failure
Exit status 4. Fault code 24.	Task checkpoint read failure
Exit status 4. Fault code 26.	Task exit with outstanding I/O

## System Boot Procedure Error Codes

System boot procedure errors can be caused by the file having been deleted, corruption of the task image on disk, an invalid file with the same name in the same directory, etc.

For User Action, refer to Chapter 1, Software Application Errors.

The following error occurs when the system boot procedure fails to install a necessary task.

**Code:** CBOOT INS error [filespec]  
 REQ: [req] Task: [taskname]  
 Status: [status 1] [status 2] [status 3]

**Explanation:**

[filespec] is the filespec of the task or common which couldn't be installed.  
 (LB:[ZZSYS]XXXX.TSK)

- [req] = 65 if the task or common was to be installed as read/write, noremove
- = 69 if the task or common was to be installed as fixed and noremove
- = 73 if the task or common was to be installed as read only and noremove

[taskname] is the name of the task or common that was installed

[status 1] is the number of status parameters passed back

[status 2] is a PROTSK server specific error-word 1

[status 3] is a PROTSK server specific error-word 2

**Code:** CBOOT System Error status1 status2 status3

**Explanation:**

<i>Status1</i>	<i>Status2</i>	<i>Status3</i>	<i>Explanation</i>
2	DSW <sup>2</sup>	0	Cannot start CSTART
4	DSW	0	Cannot start C\$CTEX
7	DSW	0	Error in (create logical) directive
129.	DSW	0	Cannot start C\$BTLG
130.	DSW	0	Waiting for start

<sup>2</sup> DSW is an acronym for "directive status word." See Table 3-2 for a list of possible DSW values.

## CTEX ERROR MESSAGES

CTEX is the “dispatcher” that controls the application activity within P/OS.

When faults occur, CTEX displays the following error messages:

**Code:** CTEX system error 1 n2 n3

**Explanation:** The dispatcher encountered an error while monitoring the terminal. The second and third status values (n2 and n3) contain the specific errors listed below.

**User Action:** See codes below for appropriate action.

**Code:** CTEX system error 1 1 RMS\_STS

**Explanation:** The dispatcher encountered a file error while accessing a file. This is a nonfatal error condition. It results in any default system account you have defined being ignored.

**User Action:** To recover from this error condition you should delete the file LB1:[ZZSYS]TERMINALS.SYS. See your system manager to delete this file. You can then define the default system account again.

**Code:** CTEX system error 1 2 DSW

**Explanation:** The dispatcher could not start the login process on the terminal. This problem may occur if you have run out of system dynamic memory or if the Login task was removed from the installed task list.

**User Action:** Reboot the system.

**Code:** CTEX system error 1 3 DSW

**Explanation:** The dispatcher could not start the Main Menu task on the terminal. This problem may occur if you have run out of system dynamic memory or if the Main Menu task was removed from the installed task list.

**User Action:** Reboot the system.

**Notes:** RMS\_STS is the Record Management System (RMS) status. When reporting errors this value is important to determine the state of the file(s) that the P/OS dispatcher manipulates.

DSW means the Directive Status Word. When reporting errors this value is important in determining the condition of your system.

**Code:** CTEX system error 1 4 DSW

**Explanation:** The dispatcher could not start the logout process on the terminal. This problem may occur if you have run out of system dynamic memory or if the Logout task was removed from the installed task list.

**User Action:** Reboot the system.

**Code:** CTEX system error 1 5 1

**Explanation:** The dispatcher could not attach the terminal. This problem may be encountered if some background application or task has the terminal attached, or if you have no system dynamic memory.

**User Action:** Reboot the system.

**Code:** CTEX system error 1 11. DSW

**Explanation:** The dispatcher encountered an error trying to assign a LUN to the terminal.

**User Action:** Reboot and call your local Customer Support Center.

**Code:** CTEX system error 1 12. DSW

**Explanation:** The dispatcher encountered an error while trying to kill an outstanding I/O to the terminal. This may be caused by no system dynamic memory. This message is always followed by a message informing you that the dispatcher could not attach the terminal.

**User Action:** Reboot the system.

**Code:** CTEX system error 1 13. DSW

**Explanation:** The dispatcher encountered an error trying to issue a MARKTIME directive. This message may be displayed if you run out of system dynamic memory.

**User Action:** Reboot the system.

**Code:** CTEX system error 1 14. DSW

**Explanation:** The dispatcher encountered an error trying to start the SETUP task on the terminal. This problem may occur if you have run out of system dynamic memory or if the SETUP task was removed from the installed task list.

**User Action:** Reboot the system.

**Code:** CTEX system error 1 15. DSW

**Explanation:** The dispatcher could not set up the terminal characteristics. This message is an informative error message and your system may still continue to operate successfully.

**User Action:** Call your local Customer Support Center.

**Code:** CTEX system error 1 2 DSW

**Explanation:** The dispatcher encountered an error while trying to receive data from other tasks in the system.

**User Action:** Call your local Customer Support Center. Your system should continue to run even after this message is displayed.

**Code:** CTEX system error 99. 4 n3

**Explanation:** The system has encountered a fatal error. The third status value (n3) contains the specific error.

**User Action:** See codes below for appropriate action.

**Code:** CTEX system error 99. 4 5

**Explanation:** Checkpoint space allocation error. This message means that there is not enough physical memory to contain all of the system and application components and that the system checkpoint file is exhausted. The checkpoint file is where system and application components are stored in an attempt to free physical memory in order to continue system operation.

**User Action:** Wait a few moments. If your system continues to display the message, reboot the system.

## LOGIN SCRIPT FILE PROCESSOR MESSAGES

Login Script File Processor messages will appear in the format xxx-yyy. The xxx segment appears as one of these commands:

- ASSIGN
- DEASSIGN
- IF
- INSTALL
- LOGIN
- LOGOUT
- REMOVE

The yyy segment tells why the command failed. The message sometimes has a numeric value associated with it.

### User Action:

1. Determine which condition caused the error.
2. Correct the condition.
3. If you cannot correct the condition, contact your local Customer Support Center. Refer to the Error Reporting Form in Chapter 1.

Some of the reasons for command failures appear as follows:

**Table 3-2**  
**Login Script File Processor Messages**

<i>Message</i>	<i>Explanation</i>
Error from parse.	An internal parsing error was encountered.
Expressions are of different types.	The two expressions in an IF statement are of different types. For example,  IF F\$MODE( ) .EQ. F\$STATUS THEN EXIT  where F\$MODE is a string and F\$STATUS is numeric.
Extraneous information in the script file.	There is extraneous information at the end of a script file that is otherwise valid.

**Table 3-2**  
**Login Script File Processor Messages (Cont.)**

<b>Message</b>	<b>Explanation</b>
IF operator invalid for expression(s) type.	The IF operator is invalid for the expressions. For example, IF F\$MODE( ) .EQ. "INTERACTIVE" is illegal. The IF operator should be .EQS.
Illegal IF operator.	An illegal IF operation was found in an otherwise valid IF statement.
**INTERNAL** Buffer overflow.	LOGIN encountered an internal buffer overflow.
Invalid command.	An invalid command was found by the script file processor.
Invalid expression syntax.	An invalid expression was found in an otherwise valid IF statement.
Invalid or contradictory qualifier.	The LOGIN script file processor found an invalid or contradictory qualifier.
Invalid task name.	The task name supplied in the RUN, REMOVE, or INSTALL command is invalid.
No equivalence name supplied.	The ASSIGN or DEASSIGN command was used, but no equivalence name was supplied.
No Logical name supplied.	The ASSIGN or DEASSIGN command was used, but no logical name was supplied as an argument.
No task name specified.	The RUN, REMOVE, or INSTALL command was used, but no task name was supplied in the command line.
Syntax error.	The script file contains a syntax error.

## **PRIMITIVE ERROR CODES**

### **Directive Status Word (DSW) Messages**

These codes will appear in either DECIMAL or OCTAL format.

For User Action, refer to Chapter 1, Software Application Errors.

**Table 3-3**  
**Directive Status Word Error Messages**

<i>Code</i>	<i>Decimal</i>	<i>Octal</i>	<i>Explanation</i>
IE.UPN	-01.	177777	Insufficient dynamic storage; see also IE.NDR
IE.INS	-02.	177776	Specified task not installed
IE.PTS	-03.	177775	Partition too small for task
IE.UNS	-04.	177774	Insufficient dynamic storage for send
IE.ULN	-05.	177773	Unassigned LUN
IE.HWR	-06.	177772	Device handler not resident
IE.ACT	-07.	177771	Task not active
IE.ITS	-08.	177770	Directive inconsistent with task state
IE.FIX	-09.	177767	Task already fixed/unfixed
IE.CKP	-10.	177766	Issuing task not checkpointable
IE.TCH	-11.	177765	Task is checkpointable
IE.RBS	-15.	177761	Receive buffer is too small
IE.PRI	-16.	177760	Privilege violation
IE.RSU	-17.	177757	Resource in use
IE.NSW	-18.	177756	No swap space available
IE.ILV	-19.	177755	Illegal vector specified
IE.ITN	-20.	177754	Invalid table number
IE.LNF	-21.	177753	Logical name not found
IE.AST	-80.	177660	Directive issued/not issued from AST
IE.MAP	-81.	177657	Illegal mapping specified
IE.IOP	-83.	177655	Window has I/O in progress
IE.ALG	-84.	177654	Alignment error
IE.WOV	-85.	177653	Address window allocation overflow
IE.NVR	-86.	177652	Invalid region ID
IE.NVW	-87.	177651	Invalid address window ID
IE.ITP	-88.	177650	Invalid TI parameter
IE.IBS	-89.	177647	Invalid send buffer size
IE.LNL	-90.	177646	LUN locked in use
IE.IUI	-91.	177645	Invalid UIC
IE.IDU	-92.	177644	Invalid device or unit
IE.ITI	-93.	177643	Invalid time parameters
IE.PNS	-94.	177642	Partition/region not in system
IE.IPR	-95.	177641	Invalid priority
IE.ILU	-96.	177640	Invalid LUN
IE.IEF	-97.	177637	Invalid event flag
IE.ADP	-98.	177636	Part of DPB out of user's space
IE.SDP	-99.	177635	DIC or DPB size, or subfunction invalid
IS.CLR	0.	0	Event flag was clear
IS.SET	2.	2	Event flag was set
IS.SPD	2.	2	Task was suspended
IS.SUP	3.	3	Logical name superseded

## Input and Output (I/O) Error Messages

The table below lists input and output (I/O) error codes. The codes are returned in the low byte of the first word of the I/O status block. The octal number listed is the low-order byte of the complete value.

For User Action, refer to Chapter 1, Software Application Errors.

**Table 3-4**  
**I/O Error Codes**

<b>Code</b>	<b>Decimal</b>	<b>Octal</b>	<b>Explanation</b>
IE.BAD	-01.	377	Bad parameters
IE.IFC	-02.	376	Invalid function code
IE.DNR	-03.	375	Device not ready
IE.VER	-04.	374	Parity error on device
IE.ONP	-05.	373	Hardware option not present
IE.SPC	-06.	372	Illegal user buffer
IE.DNA	-07.	371	Device not attached
IE.DAA	-08.	370	Device already attached
IE.DUN	-09.	367	Device not attachable
IE.EOF	-10.	366	End-of-file detected
IE.EOV	-11.	365	End-of-volume detected
IE.WLK	-12.	364	Write attempted to locked unit
IE.DAO	-13.	363	Data overrun
IE.SRE	-14.	362	Send/receive failure
IE.ABO	-15.	361	Request terminated
IE.PRI	-16.	360	Privilege violation or device not mounted
IE.RSU	-17.	357	Shareable resource in use
IE.OVR	-18.	356	Illegal overlay request
IE.BYT	-19.	355	Odd byte count or virtual address
IE.BLK	-20.	354	Logical block number too large
IE.MOD	-21.	353	Invalid UDC module number
IE.CON	-22.	352	UDC connect error
IE.NOD	-23.	351	System dynamic memory
IE.DFU	-24.	350	Device full
IE.IFU	-25.	347	Index file full
IE.NSF	-26.	346	No such file
IE.LCK	-27.	345	Locked from read/write access
IE.HFU	-28.	344	File header full
IE.WAC	-29.	343	Accessed for write
IE.CKS	-30.	342	File header checksum failure
IE.WAT	-31.	341	Attribute control list format error
IE.RER	-32.	340	File processor device read error
IE.WER	-33.	337	File processor device write error
IE.ALN	-34.	336	File already accessed on LUN
IE.SNC	-35.	335	File ID, file number check
IE.SOC	-36.	334	File ID, sequence number check
IE.NLN	-37.	333	No file accessed on LUN
IE.CLO	-38.	332	File was not properly closed
IE.NBF	-39.	331	File buffer space unavailable

**Table 3-4**  
**I/O Error Codes (Cont.)**

<b>Code</b>	<b>Decimal</b>	<b>Octal</b>	<b>Explanation</b>
IE.RBG	- 40.	330	Illegal record size
IE.NBK	- 41.	327	File exceeds space allocated, no blocks
IE.ILL	- 42.	326	Illegal operation on file descriptor block
IE.BTP	- 43.	325	Bad record type
IE.RAC	- 44.	324	Illegal record access bits set
IE.RAT	- 45.	323	Illegal record attribute bits set
IE.RCN	- 46.	322	Illegal record number—too large
IE.ICE	- 47.	321	Internal consistency error
IE.2DV	- 48.	320	Rename—two different devices
IE.FEX	- 49.	317	Rename—file name already in use
IE.BDR	- 50.	316	Bad directory syntax
IE.RNM	- 51.	315	Cannot rename old file system
IE.BDI	- 52.	314	Bad directory syntax
IE.FOP	- 53.	313	File already open
IE.BNM	- 54.	312	Bad file name
IE.BDV	- 55.	311	Bad device name
IE.BBE	- 56.	310	Bad block on device
IE.DUP	- 57.	307	Enter—duplicate entry in directory
IE.STK	- 58.	306	Not enough stack space (FCS or FCP)
IE.FHE	- 59.	305	Fatal hardware error on device
IE.NFI	- 60.	304	File ID was not specified
IE.ISQ	- 61.	303	Illegal sequential operation
IE.EOT	- 62.	302	End-of-tape detected
IE.BVR	- 63.	301	Bad version number
IE.BHD	- 64.	300	Bad file header
IE.OFL	- 65.	277	Device off line
IE.BCC	- 66.	276	Block check, CRC, or framing error
IE.ONL	- 67.	275	Device on line
IE.NNN	- 68.	274	No such node
IE.NFW	- 69.	273	Path lost to partner
IE.BLB	- 70.	272	Bad logical buffer
IE.TMM	- 71.	271	Too many outstanding messages
IE.NDR	- 72.	270	No dynamic space available
IE.URJ	- 73.	267	Connection rejected by user
IE.BTF	- 76.	264	Bad tape format
IE.NNC	- 77.	263	Not ANSI 'D' format byte count
IE.NNL	- 78.	262	Not a network LUN
IE.NLK	- 79.	261	Task not linked to specified ICS/ICR interrupts
IE.NST	- 80.	260	Specified task not installed
IE.AST	- 80.	260	No AST specified in connect
IE.FLN	- 81.	257	Device off line when off-line request issued
IE.IES	- 82.	256	Invalid escape sequence
IE.PES	- 83.	255	Partial escape sequence
IE.ALC	- 84.	254	Allocation failure
IE.ULK	- 85.	253	Unlock error
IE.WCK	- 86.	252	Write check failure
IE.CNR	- 96.	240	Connection rejected

## I/O Success Codes

These codes are presented here for your information. They are only meant to add to the completeness of this book.

**Table 3-5**  
**I/O Success Codes**

<b>Code</b>	<b>Decimal</b>	<b>Octal</b>	<b>Explanation</b>
IS.PND	00.	000	Operation pending.
IS.SUC	+01.	001	Operation complete, success.
IS.RDD	+02.	002	Floppy disk successful completion of a read physical, and deleted data mark was seen in sector header.
IS.DAO	+02.	002	Successful but with data overrun. (Do not confuse with IE.DAO.)
IS.TMO	+02.	002	Successful completion on read terminated by time-out.
IS.TNC	+02.	002	(PCL) Successful transfer but message truncated (receive buffer too small).
IS.CHW	+04.	004	(IBM COMM) Data read was result of IBM host chained-write operation.
IS.BV	+05.	005	(A/D READ) At least one bad value was read (remainder may be good). Bad channel is indicated by a negative value in the buffer.

## P/OS DRIVERS

Each driver that is bundled with P/OS returns a subset of the I/O status codes. This section lists the status codes returned by each driver. Also listed are subcodes<sup>3</sup> in the high byte of the status word. (For example, the terminal driver returns input terminator information in the high byte of an IS.SUC return.)

### I/O Full-Word Subcodes for IS.SUC Return in Terminal Driver

The numbers in the code are divided into three groups:

- word value
- low byte
- high byte

<sup>3</sup> Subcodes returned with IS.SUC are word values. Subcodes returned with IE.ABO, and all I/O status codes, are byte values.

For example, in the first code IS.CR, 006401 is the word value; 001 is the low byte; and 015 is the high byte. The low and high byte values are shown here for information only.

For User Action, refer to Chapter 1, Software Application Errors.

**Table 3-6**  
**I/O Full-Word Subcodes**

<b>Code</b>	<b>Word Value</b>	<b>Low Byte</b>	<b>Byte</b>	<b>Explanation</b>
IS.CR	006401	001	015	RETURN was terminator
IS.ESC	015401	001	033	ESCAPE (altmode) was terminator
IS.CC	001401	001	003	CTRL/C (INTERRUPT-DO) was terminator
IS.ESQ	115401	001	233	Escape sequence was terminator
IS.PES	100001	001	200	Partial escape sequence terminator
IS.EOT	002001	001	004	EOT was terminator, block mode input

#### **I/O High-Byte Subcodes for IE.ABO Return in Terminal Driver**

These codes apply to an operation aborting after passing preprocessing.

For User Action, refer to Chapter 1, Software Application Errors.

**Table 3-7**  
**I/O High-Byte Subcodes**

<b>Code</b>	<b>Decimal</b>	<b>Octal</b>	<b>Explanation</b>
SE.ICN	01.	001	Illegal characteristic name
SE.FIX	02.	002	Attempt to change fixed characteristic
SE.BIN	03.	003	Illegal value for binary characteristic
SE.VAL	04.	004	Invalid value for nonbinary characteristic
SE.TER	05.	005	Invalid terminal type
SE.SPD	06.	006	Invalid speed for interface
SE.SPL	07.	007	Invalid split speed for interface
SE.PAR	08.	010	Invalid parity type for interface
SE.LPR	09.	011	Other invalid line parameters
SE.NSC	10.	012	Interface does not have settable characteristics
SE.UPN	11.	013	No space to save default characteristics
SE.NIH	12.	014	Characteristic not assembled in handler
SE.ATA	13.	015	Terminal attached with AST notification
SE.NAT	14.	016	Terminal not attached
SE.IAA	15.	017	Invalid AST address specified

**I/O Status for Communication Driver, XKDRV**

These codes apply to errors encountered with the communication driver.

For User Action, refer to Chapter 1, Software Application Errors.

**Table 3-8**  
**I/O Status (Communication Driver)**

<b>Code</b>	<b>Decimal</b>	<b>Octal</b>	<b>Explanation</b>
IS.PND	+00.	000	I/O request pending
IS.SUC	+01.	001	Successful completion
IS.TMO	+02.	002	Success, request timed out
IE.TMO	-95.	241	Unsuccessful completion due to a timeout

**I/O High-Byte Subcodes for IE.ABO Return in Communication Driver**

These codes apply to an operation aborting after passing preprocessing.

For User Action, refer to Chapter 1, Software Application Errors.

**Table 3-9**  
**I/O Subcodes (Communication Driver)**

<b>Code</b>	<b>Decimal</b>	<b>Octal</b>	<b>Explanation</b>
SE.VAL	+04.	004	Invalid value for non-binary characteristic
SE.NIH	+12.	010	Characteristic not assembled in handler

**I/O Status for Disk Drivers**

These codes apply to errors encountered with the disk drivers.

For User Action, refer to Chapter 1, Software Application Errors.

**Table 3-10**  
**I/O Status for Disk Drivers**

<b>Code</b>	<b>Decimal</b>	<b>Octal</b>	<b>Explanation</b>
IS.PND	+00.	000	Operation pending
IS.SUC	+01.	001	Operation complete, success
IE.MII	-99.	235	Media inserted incorrectly

**FMS-11 ERROR MESSAGES**

FMS-11 is Digital's Form Management System. FMS-11 allows you to use forms to collect and display data. For a complete list of FMS-11 error messages, refer to the *FMS-11/RSX Software Reference Manual*.

**Code: ALPHABETIC REQUIRED**

**Explanation:** An alphabetic character (A–Z, a–z, or a space) is required in the current position.

**User Action:** Enter only an alphabetic character (A–Z, a–z, or a space) in the current position.

**Code: ALPHANUMERIC REQUIRED**

**Explanation:** An alphabetic or numeric character is required in the current position.

**User Action:** Enter only an alphabetic or numeric character in the current position.

**Code: FULL FIELD REQUIRED**

**Explanation:** The current field must be completely filled and contain no fill characters.

**User Action:** Completely fill the current field with valid characters.

**Code: INPUT REQUIRED**

**Explanation:** At least one non-fill character must be entered in the current field. For example, a space.

**User Action:** Enter at least one valid character.

**Code: NO HELP AVAILABLE**

**Explanation:** No further help is available for the current form.

**User Action:** Press RETURN to continue editing the form.

**Code: NON-DISPLAYABLE CHARACTER**

**Explanation:** No validation is required in the current position. However, the character entered cannot be displayed and therefore is invalid.

**User Action:** Enter a valid displayable character. A valid displayable character is any alphanumeric character.

**Code:** NUMERIC REQUIRED

**Explanation:** A numeric character (0–9) is required in the current position.

**User Action:** Enter only a numeric character (0–9) in the current position.

**Code:** SIGNED NUMERIC REQUIRED

**Explanation:** A valid signed numeric character (0–9, period, comma, hyphen, or plus sign) is required in the current position.

**User Action:** Enter only a valid signed numeric character (as listed above) in the current position.

## **RMS-11 (RECORD MANAGEMENT SYSTEM)**

### **RMSIFL Error Messages**

If you see an error message beginning with ?IFL, there is an RMS-11 Indexed File Load Utility error. Refer to the *RSX-11M/M-PLUS RMS-11 Utilities* manual in the PRO/Tool Kit for an explanation. If you do not have the PRO/Tool Kit, use the Error Reporting Form to collect the information, and call your local Customer Support Center.

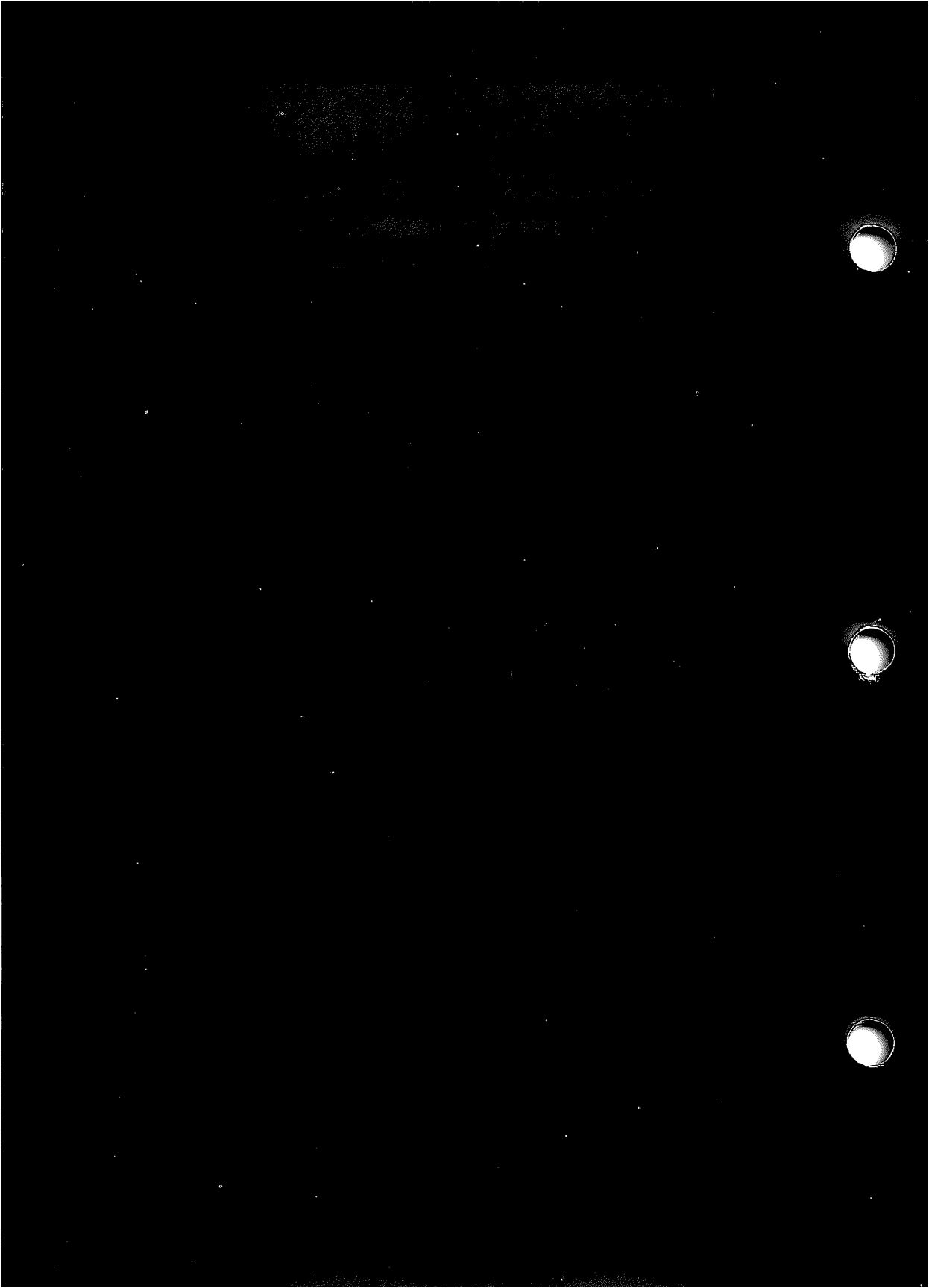
### **Completion Codes**

If you see an error message beginning with ER\$xxx, there is an RMS-11 Completion error. Refer to the *PRO/RMS-11 MACRO Programmer's Guide* in the PRO/Tool Kit for an explanation. If you do not have the PRO/Tool Kit, use the Error Reporting Form to collect the information, and call your local Customer Support Center.

# 4

---

## Terminal Subsystem Bugchecks



## Chapter 4

---

### Terminal Subsystem Bugchecks

#### THE TERMINAL SUBSYSTEM

The Terminal Subsystem is the software that controls video display for both text and graphics output, and mediates keyboard input for the application program.

The last two digits in the code (represented here by xx) represent the SST (synchronous system trap) vector number, multiplied by two. Also, the second 'x' in the error code represents the program counter number of the failure.

**Code:** 1004xx

**Explanation:** This code identifies a problem with the terminal firmware. The reasons for this error could be a corrupt system file, a bad system memory, a bad video memory, or a bug in the software.

**User Action:**

1. Copy down the numbers on the screen.
2. Check the power cable between the power supply and the motherboard.
3. Reboot the system.
4. Retry the operation.
5. Back up your system using the instructions in the *Hard Disk System User's Guide*.
6. Reinstall the system.
7. If it still fails, call your Customer Support Center.

**Code:** 1005xx

**Explanation:** This code identifies a failure in the keyboard software. The reasons for this failure could be a corrupt system file, a corrupt block on the hard disk, a bad system memory, or a hardware problem on the system board/keyboard controller.

**User Action:**

1. Replace LB:[ZZSYS]KBTTAB.DAT (found in the Distribution Kit).
2. Retry the operation.
3. If it still fails, call your local Customer Support Center.

**Code:** 1006xx/1007xx

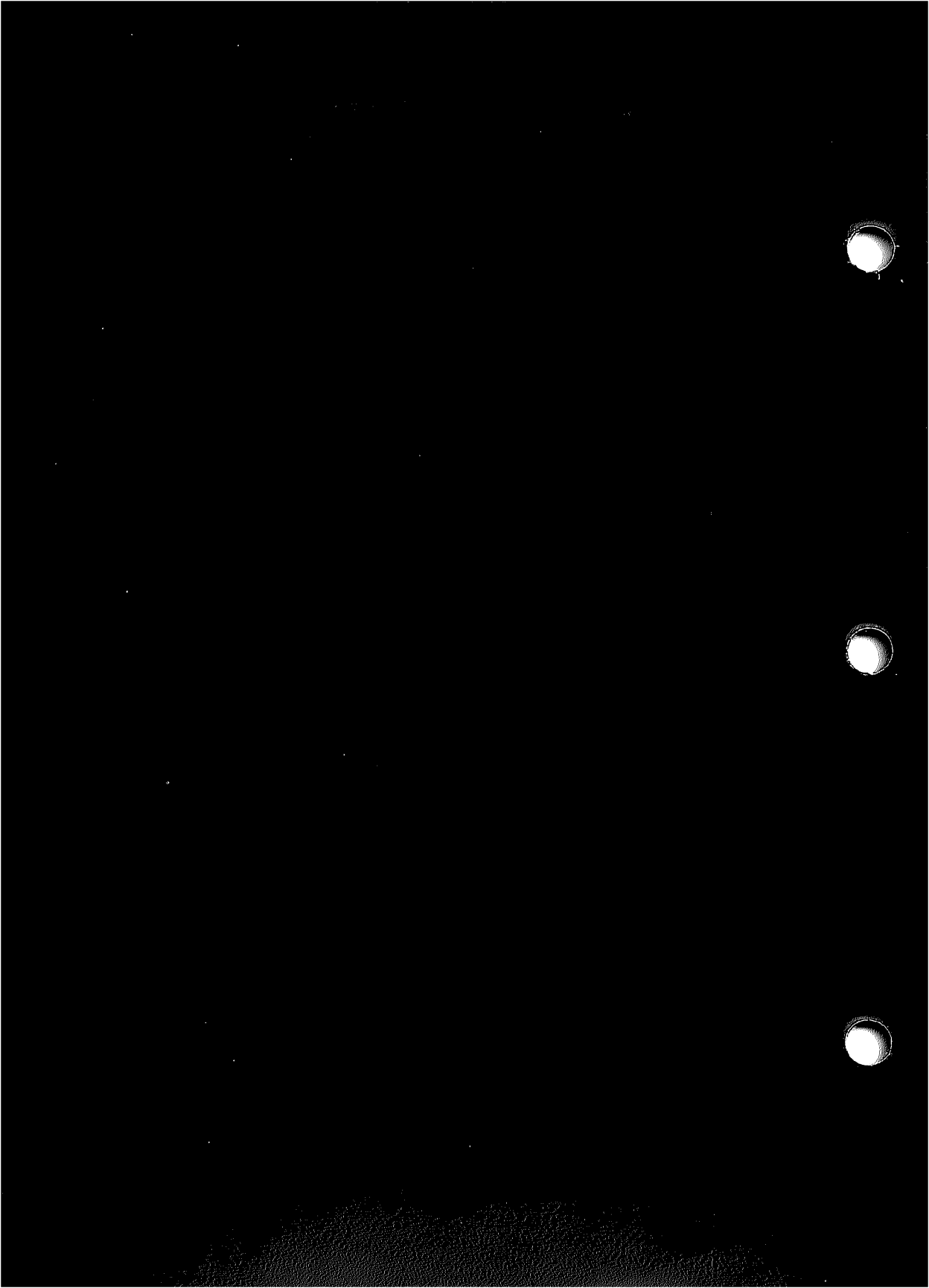
**Explanation:** The low byte of these error codes is the directive status. The reasons for this error could be a corrupt system file, a bad system memory, a bad video memory, or a bug in the software.

**User Action:**

1. Copy down the numbers on the screen.
2. Reboot the system.
3. Retry the operation.
4. Back up your system using the instructions in the *Hard Disk System User's Guide*.
5. Reinstall the system.
6. If it still fails, call your local Customer Support Center.

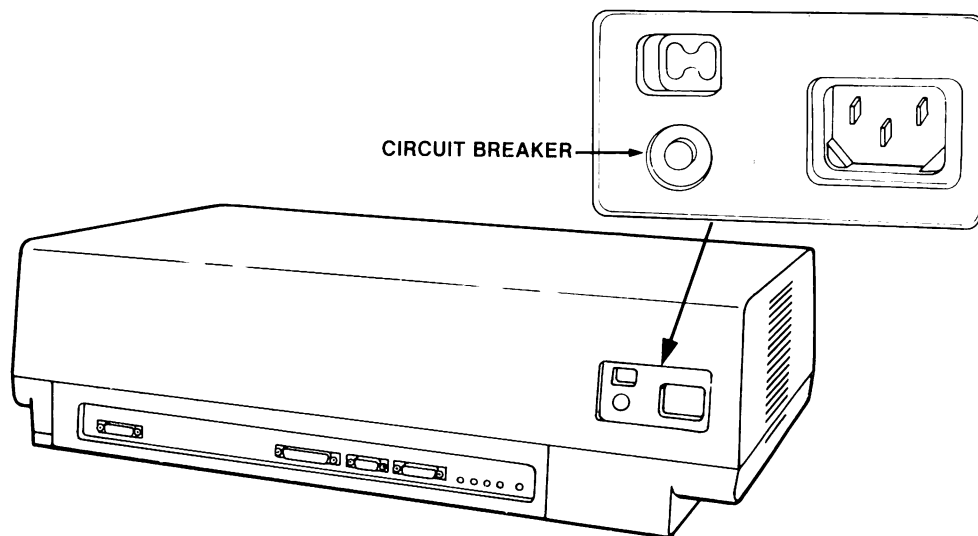
---

# Appendix A

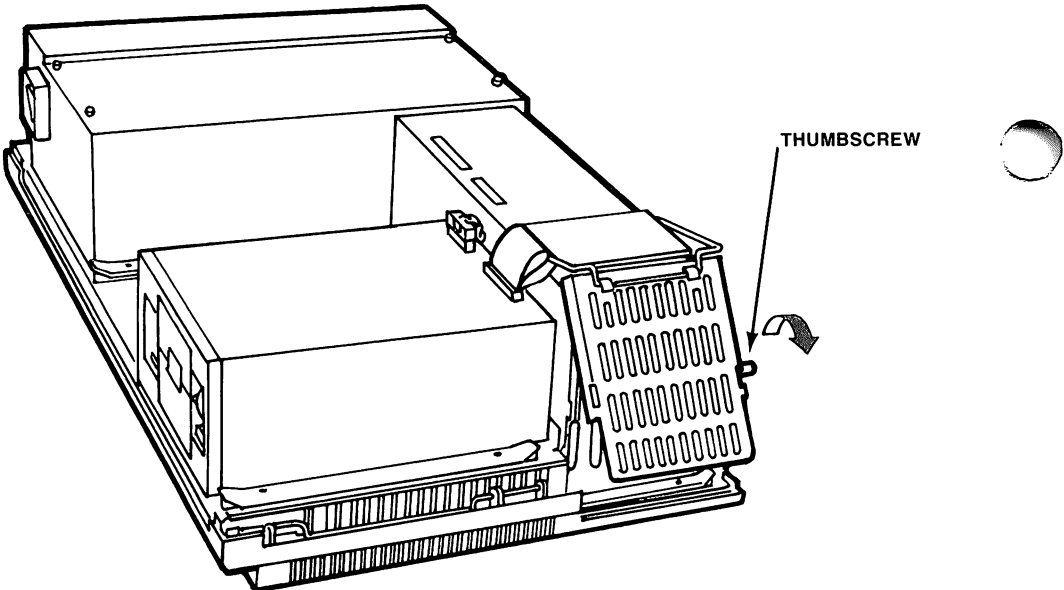


# Appendix A

## Hardware Diagrams



**Figure A-1**  
**System Circuit Breaker**



Loosen thumbscrew and open card cage door

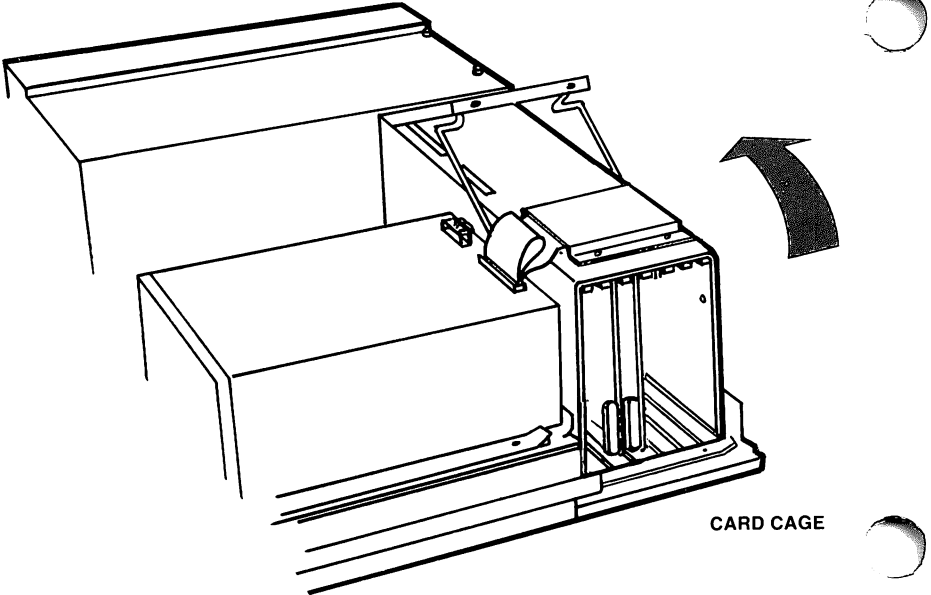
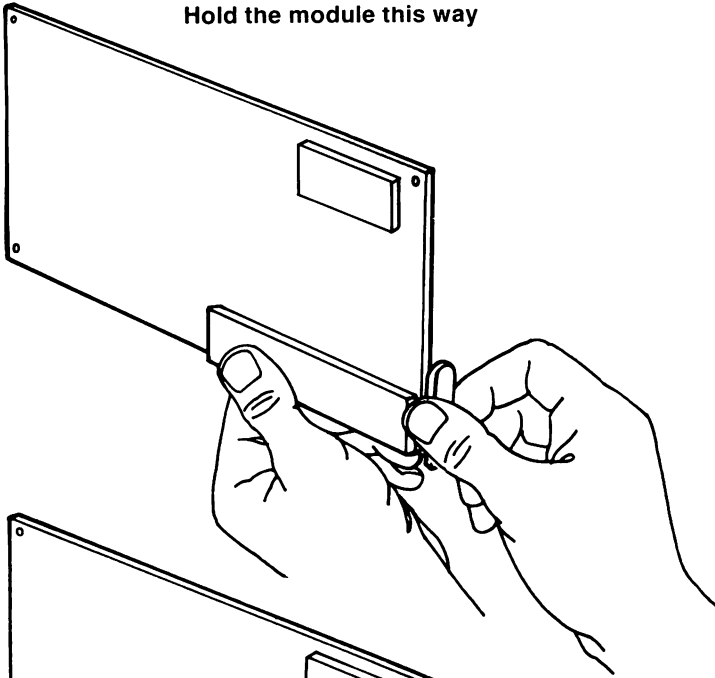
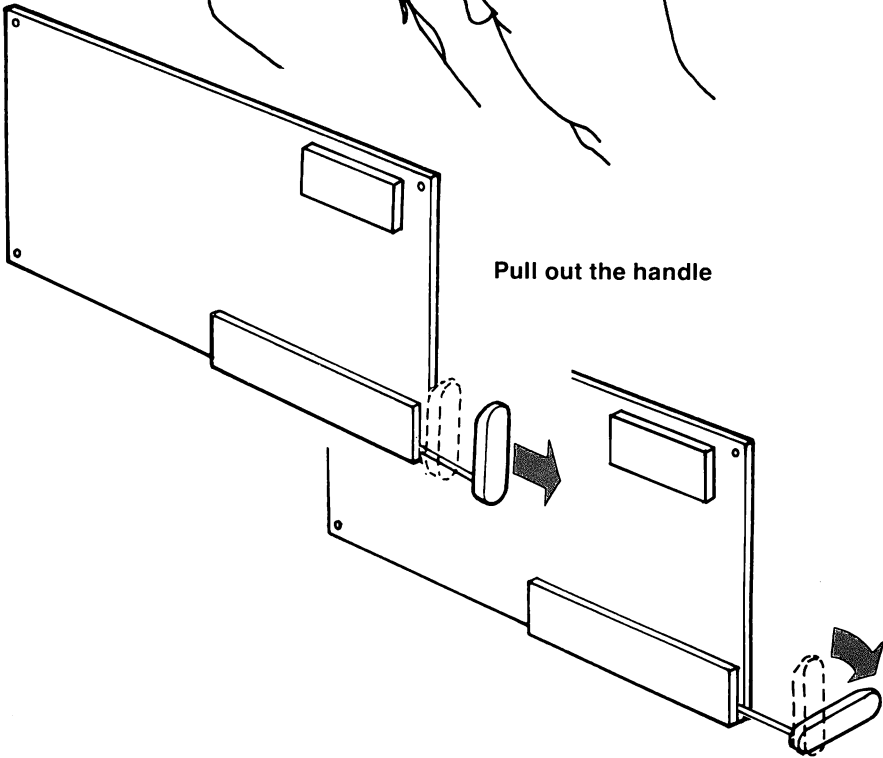


Figure A-2  
System Unit Card Cage

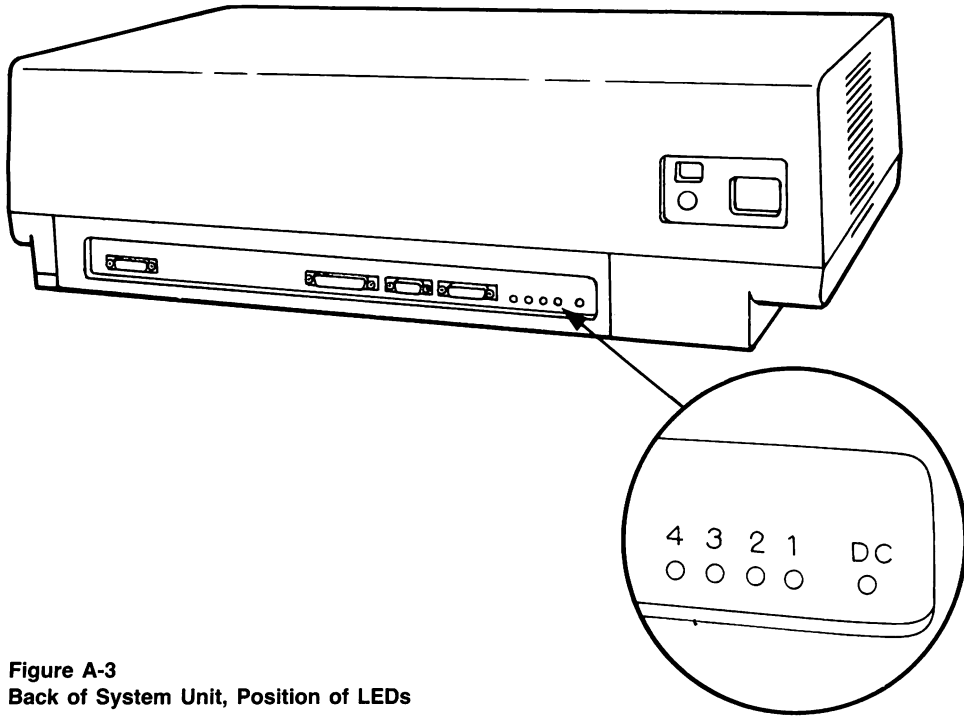
Hold the module this way



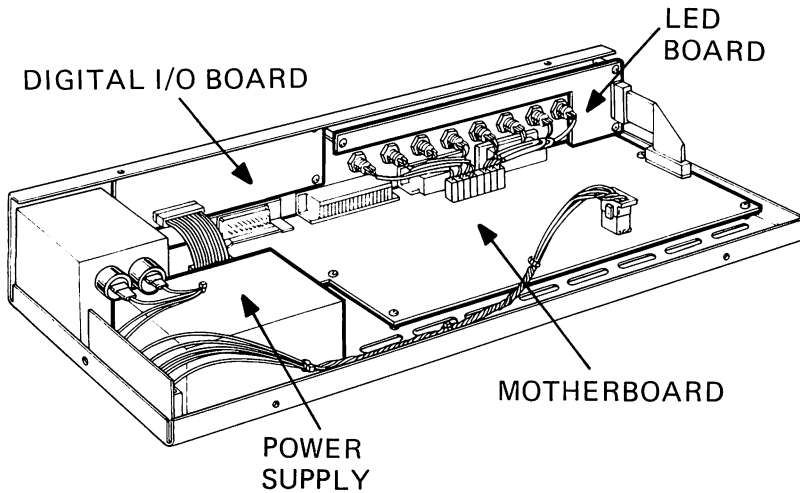
Pull out the handle



Firmly turn the handle 90°



**Figure A-3**  
**Back of System Unit, Position of LEDs**



**Figure A-4**  
**System Unit, Showing Motherboard**

---

# Appendix B



## Appendix B

---

### System Installation Error Codes

When the system installation is unsuccessful, the following message appears:

An error has occurred that prevents successful installation. Please write down the following error codes and refer to your Hard Disk System User's Guide for instructions.

[error text here appears in English words]

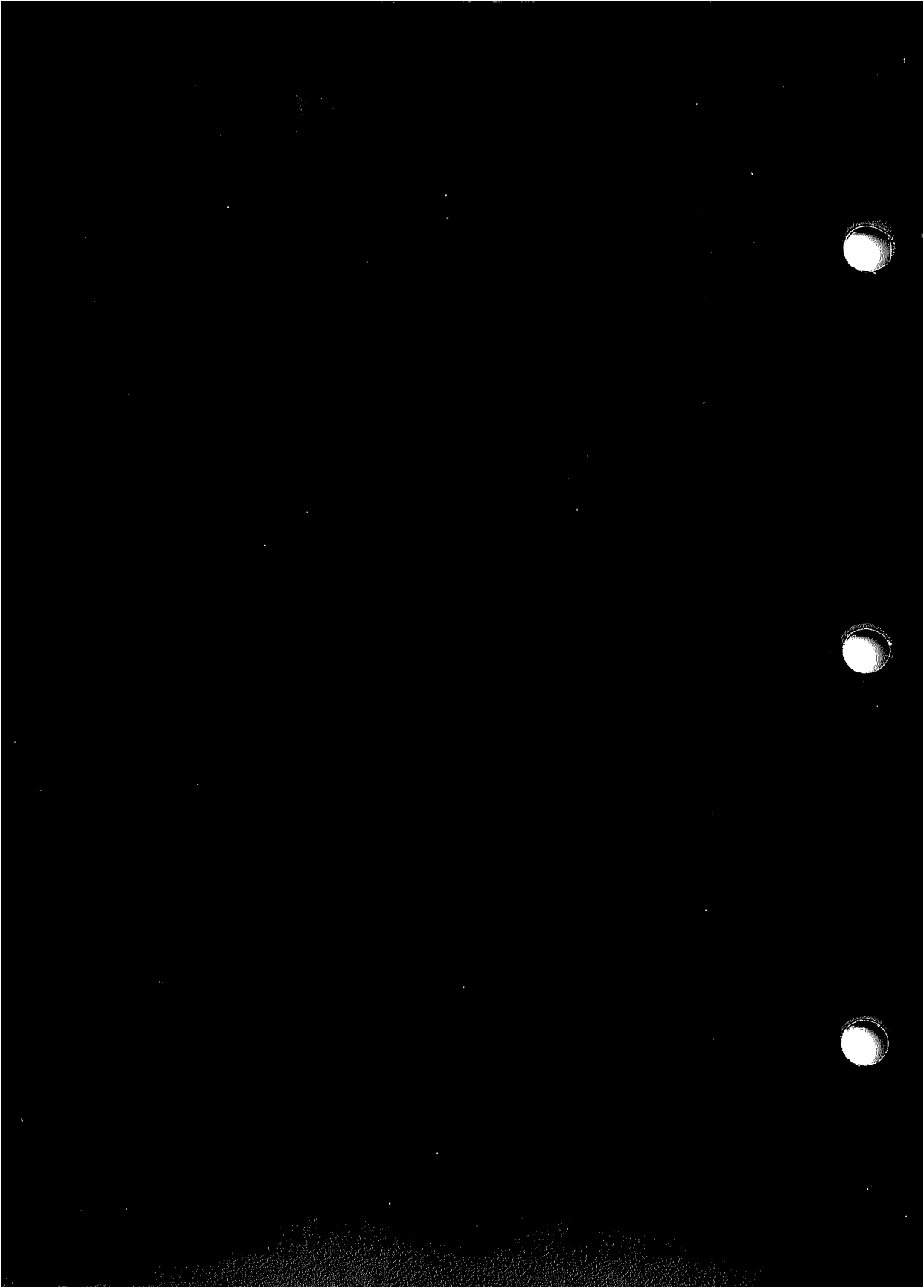
Error code displays either in decimal or octal at instruction address  
[8-word status values]

For User Action, refer to Chapter 1, Software Application Errors.

**Table B-1**  
**System Installation Error Codes**

<i>Decimal</i>	<i>Octal</i>	<i>Explanation</i>
0.	000000	Terminal output error
4.	000004	Terminal input error
8.	000010	Directive error
12.	000014	CTEX error
16.	000020	Message error
20.	000024	POSSUM service error
24.	000030	RMS-11 error
28.	000034	Keyboard SR error
32.	000040	Setup/reset error
36.	000044	Internal errors
40.	000050	FBI error (Fmt/Bad/Ini)
44.	000054	Create Directory error
48.	000060	Plug Boot Block error
52.	000064	Error in ASSIGN command
56.	000070	Error in UIC command

Appendix C



## Appendix C

---

### Option ID Error Codes

These codes appear when one of the Professional's options is not performing correctly.

For User Action, refer to Chapter 1, Software Application Errors.

**Table C-1**  
**Option ID Error Codes**

---

<i>Code</i>	<i>Source of Error</i>
000000	Unready Option
000011	PRO 300 Base Processor
000012	Floating Point Processor
000014	LK200 Keyboard Control
000016	LK200 Keyboard
000017	PRO 300 Printer Port
000020	PRO 300 Speaker Control
000021	PRO 300 Communication Port
000022	PRO 300 Diag/ROM Version 1.0
000023	PRO 300 Time/Date Clock
000024	PRO 300 Nonvolatile Memory
000025	PRO 300 Interrupt Controller
000026	PRO 300 Diag/ROM Version 2.0
000027	PRO 300 Maintenance Console Port
000030	PRO 300 Option Present Register
000031	PRO 300 Serial Number ROM
000032	PRO 300 Monitor Attachment
000033	PRO 300 Primary RAM
000034	PRO 300 Option RAM
000035	PRO 380 Base Processor
000036	PRO 380 Interrupt Controller

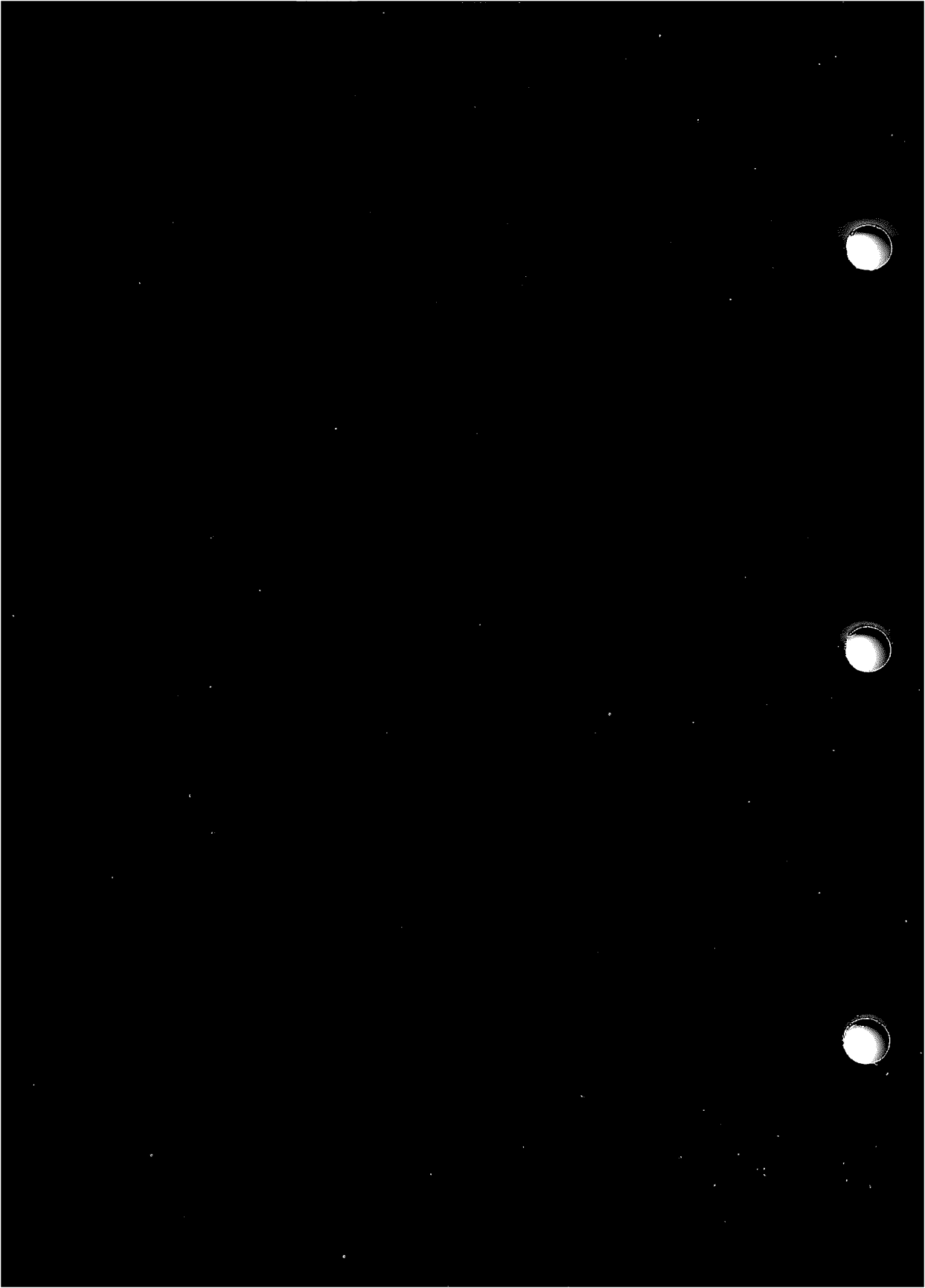
---

**Table C-1**  
**Option ID Error Codes (Cont.)**

<b>Code</b>	<b>Source of Error</b>
000037	PRO 380 Base System ROM Version 1.0
000040	PRO 300 DMA Test Module
000041	CTI Telephone Management Service
000042	CTI Ethernet Controller
000043	CTI Z80/CMP Softcard
000044	CTI T-11 Softcard
000045	IVIS Base Module Set
000046	IDLDR IEEE Option
000047	Kanji Font Module
000050	PRO 380 Bit-Map Video Base Module
000051	DRC11-AA Parallel Interface
000052	DLC11-AA Serial Interface
000053	ARC11-AA Analog Interface
000054	MRC11-AA ROM Option
000060	DECtouch Module
000401	CTI RD50 5-1/4" Winchester Disk Controller
001002	CTI Bit-Map Video Base Module
001403	CTI Bit-Map Video Extension
002004	CTI RX50 5-1/4" Winchester Disk Controller
002405	CTI Fast Serial Line
003006	IVIS System Module
010001	Tempest Keyboard
010050	PRO 380 Bit-Map Video Extension
011002	IVIS Bit-Map Base Module
011403	IVIS Bit-Map Video Extension
030050	PRO 380 Bit-Map Extension and Color Map
176775	Experimental ID with Identical Bytes
177376	Experimental ID with Identical Bytes
177775	Experimental ID
177776	Experimental ID

---

# Appendix D



## Appendix D

---

### PROTSK Error Messages

PROTSK is a function of the Professional that allows you to:

- Install a task
- Remove a task
- Fix an installed task
- Install, run, or remove an offspring task

Table D-1 lists the error codes from PROTSK that are specific to P/OS Server.

For User Action, refer to Chapter 1, Software Application Errors.

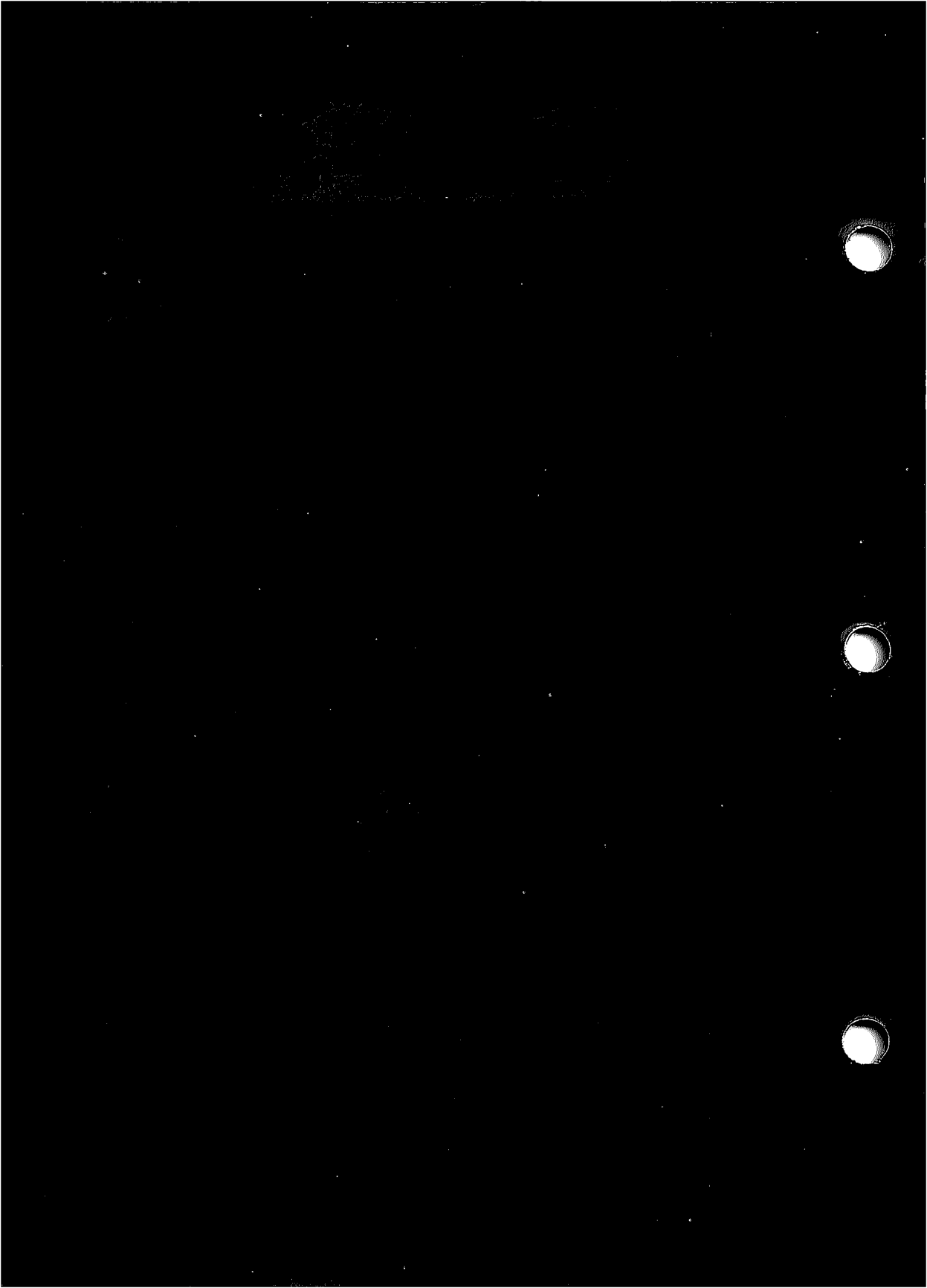
**Table D-1**  
**PROTSK Error Messages**

<i>Decimal</i>	<i>Octal</i>	<i>Explanation</i>
+1.	000001	Successful install
-1.	177777	Task name in use
-2.	177776	File not found
-3.	177775	Specified partition too small
-4.	177774	Task and partition base mismatch
-7.	177771	Length mismatch common block
-8.	177770	Base mismatch common block
-9.	177767	Too many common block requests

**Table D-1**  
**PROTSK Error Messages (Cont.)**

<i>Decimal</i>	<i>Octal</i>	<i>Explanation</i>
- 11.	177765	Checkpoint area too small
- 13.	177763	Not enough APRs for task image
- 14.	177762	File not task image
- 15.	177761	Base address must be on 4k boundary
- 16.	177760	Illegal first APR
- 18.	177756	Common block parameter mismatch
- 20.	177754	Common block not loaded
- 22.	177752	Task image virtual address overlaps common block
- 23.	177751	Task image already installed
- 24.	177750	Address extensions not supported
- 26.	177746	Checkpoint space too small, using checkpoint file
- 27.	177745	No checkpoint space, assuming not checkpointable
- 29.	177743	Illegal UIC
- 30.	177742	No pool space
- 31.	177741	Illegal use of partition or region
- 32.	177740	Access to common block denied
- 33.	177737	Task image I/O error
- 34.	177736	Too many LUNs
- 35.	177735	Illegal device
- 36.	177734	Task may not be run
- 37.	177733	Task active
- 39.	177731	Task fixed
- 40.	177730	Task being fixed
- 41.	177727	Partition busy
- 43.	177725	Common/task not in system
- 44.	177724	Region or common fixed
- 45.	177723	Can't do receive from requestor
- 46.	177722	Can't attach to requestor
- 47.	177721	Invalid request
- 48.	177720	Can't return result parameter
- 49.	177717	Error encountered on file open operation
- 50.	177716	Error encountered on file close operation
- 51.	177715	Can't get file LBN to process label blocks
- 52.	177714	Cannot get taskname
- 53.	177713	Unable to create or map to region
- 54.	177712	Cannot install task with resident header: Taskbuild /-XH illegal
- 55.	177711	Common built illegally with EXTTSK option
- 56.	177710	Cannot FIX a prototype task

Appendix E



## Appendix E

---

### P/OS Bugcheck Codes

A bugcheck is an unrecoverable error which prevents the continuation of system operation. A bugcheck occurs after the system is booted. The bugcheck display has nothing highlighted, and it shows 2 numbers (for the 350) or 8 numbers (for the 380) on the right side of the screen.

Table E-1 lists the bugcheck codes defined for P/OS Version 3.0.

For User Action, refer to Chapter 1, Software Application Errors.

**Table E-1**  
**P/OS Bugcheck Codes**

<b>Code</b>	<b>Explanation</b>
000100/xxxxxx	P/OS keyboard handler
000200/xxxxxx	Terminal driver
1004?/?/xxxxxx	P/OS terminal subsystem. Refer to the Terminal Subsystem Bugchecks in Chapter 4.
000300/xxxxxx	P/OS Executive, general
000300/000000	IOT in system state; system discovered an unrecoverable corruption
000300/000001	Stack overflow
000300/000002	Trace trap or breakpoint
000300/000003 <sup>4</sup>	Illegal instruction trap
000300/000004 <sup>4</sup>	Odd address or other trap to 4
000300/000005	Segment fault

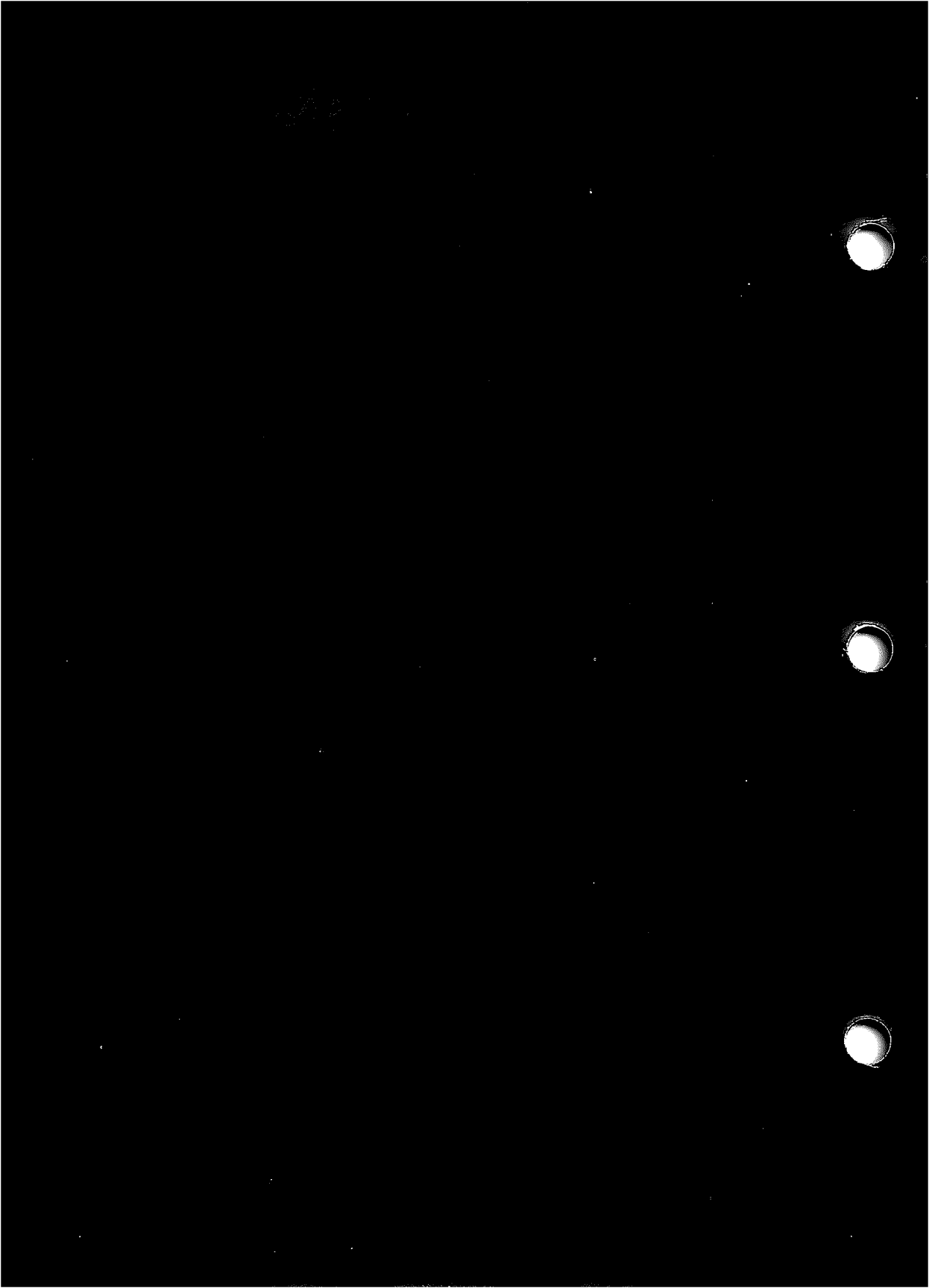
<sup>4</sup> For codes 000300/000003 and 000300/000004, check the power cable between the power supply and the motherboard first.

**Table E-1**  
**P/OS Bugcheck Codes (Cont.)**

<b>Code</b>	<b>Explanation</b>
000300/000006	A background or system task aborted or exited with outstanding I/O
000300/000007	EMT trap
000300/000010	TRAP trap
000300/000011	Pool allocation failure
000400/xxxxxx	System start-up processing
000400/000001	Can't install task CBOOT
000400/000002	Can't spawn task CBOOT
000400/000003	Can't spawn task CMAIN
000400/000007	Required startup file not found or not executable.

---

# Appendix F



## Appendix F

---

### PRO/DECnet Startup Failure Codes

For additional DECnet information, refer to the *PRO/DECnet User's Guide*.

**User Action:**

1. Reboot the system.
2. Use the Error Reporting Form in Chapter 1 and contact your local software support person if the message still appears.

**Table F-1**  
**PRO/DECnet Start-Up Messages**

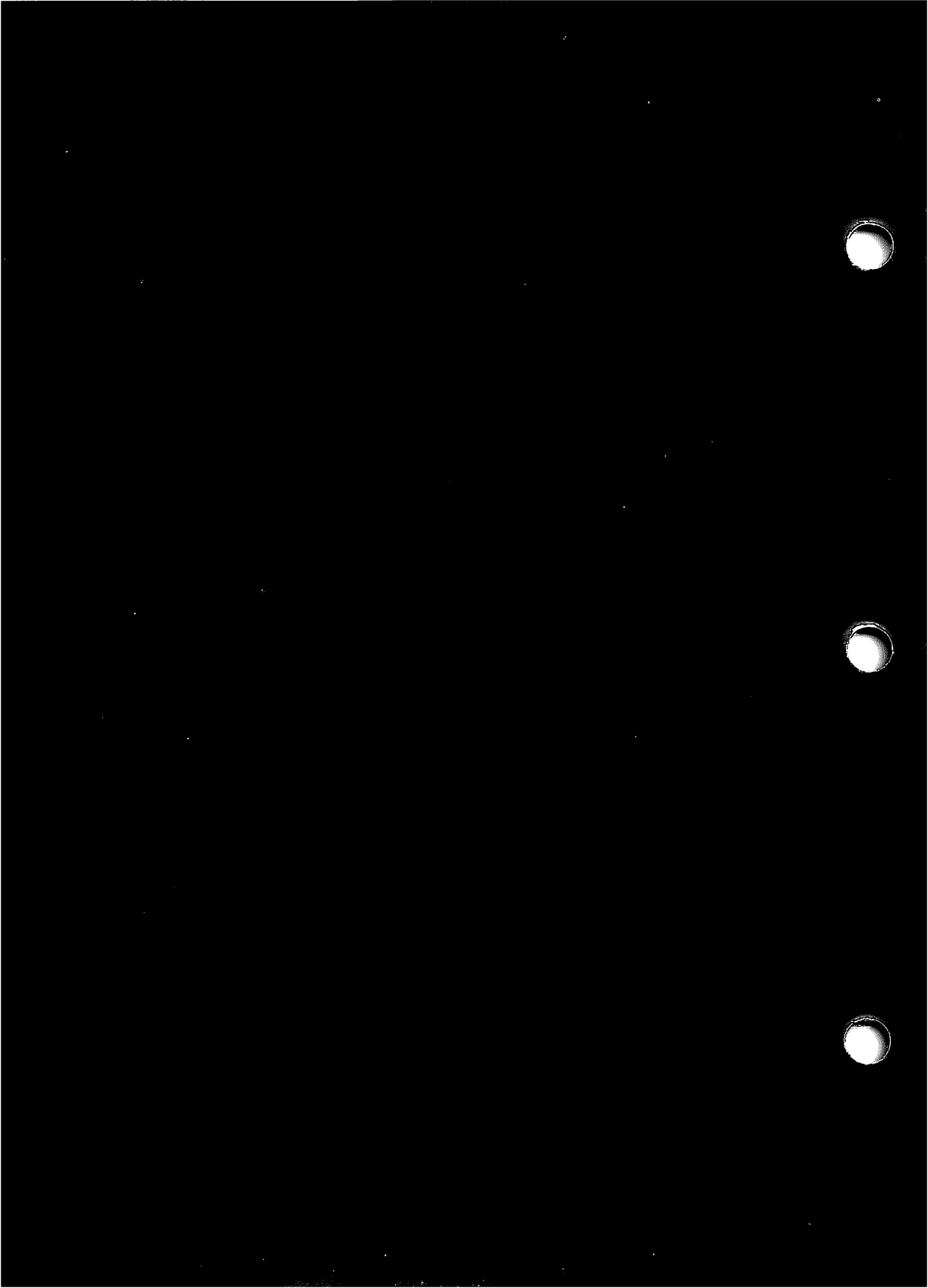
---

<b>Code</b>	<b>Explanation</b>
000400/000010	DSR corrupt
000400/000011	Bad dispatch
000400/000012	No way to boot via DECNA
000400/000013	DSR allocation failure
000400/000014	DDM vector in use
000400/000015	Required PDV not found
000400/000016	Required hardware not present

---

---

# Appendix G



## Appendix G

---

### P/OS Server Network Error Codes

Table G-1 lists the codes related to the internal workings of the P/OS Server network. Should any of these codes appear on your monitor screen, do the following:

1. Copy down the numbers on the screen.
2. Reboot your system.
3. If the problem persists, reboot the P/OS Server.
4. If problem still appears, call your local Customer Support Center.

Some codes have specific explanations. The User Action for these items is to:

1. Make sure that the workstation is registered in the DECnet remote node definition file.
2. Make sure the P/OS Server is still running.
3. Notify the system manager.

Perform these tasks first before calling your local Customer Support Center.

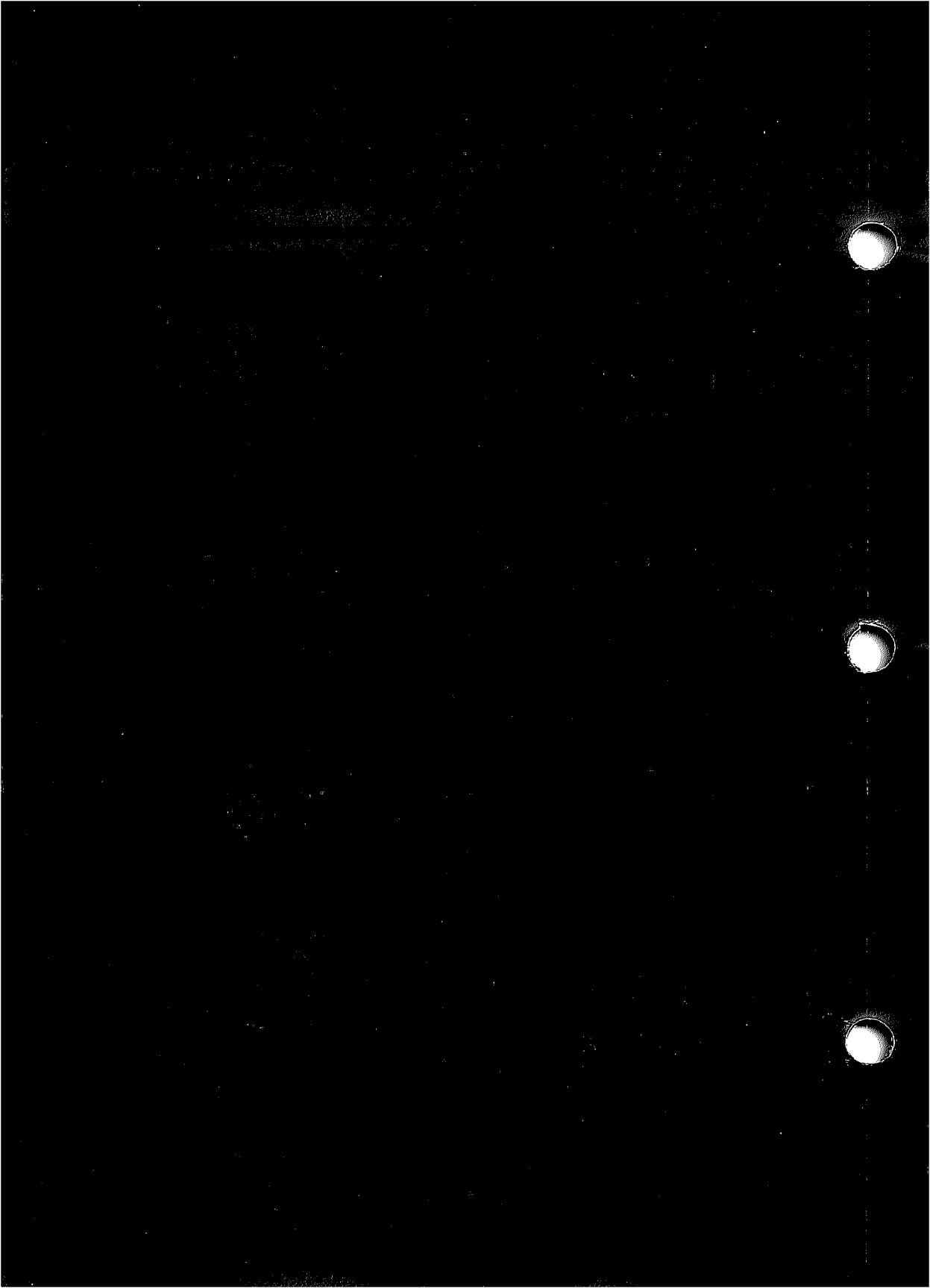
**Table G-1**  
**Server Network Messages<sup>5</sup>**

<i>Code</i>	<i>Explanation</i>
000500/000001	Error creating system channel.
000500/000002	
000500/000003	
000500/000004	
000500/000005	
000500/000006	
000500/000101	
000500/000102	
000500/000103	
000500/000104	
000500/000105	
000500/000106	
000500/000107	
000500/000110	
000500/000201	
000500/000202	
000500/000203	
000500/000204	Unable to communicate with P/OS Server during channel processing.
000500/000301	
000500/000302	Unable to communicate with P/OS Server during device select processing.
000500/000303	Unable to communicate with P/OS Server.
000500/000304	
000500/000305	
000500/000306	
000500/000307	
000500/000310	
000500/000311	
000500/000312	
000500/000313	P/OS Server has gone down.
000500/000314	
000500/000315	
000500/000316	
000500/000317	
000500/000321	
000500/000323	
000500/000324	

<sup>5</sup> Refer to the previous page for specific User Action instructions.

---

# Index



# Index

---

## Alphabetic Format Error Codes

ERHDN2 through ERHDN3, 30  
ERNODV, 30  
ERRFND through ERROPN, 30  
IE.2DV through IE.WOV, 40, 41  
IS.BV through IS.TNC, 39, 42,  
43, 44  
SE.ATA through SE.VAL, 43, 44

## Numeric Format Error Codes

-1. through -56., 67  
0., 59  
+1., 67  
12. through 56., 59  
000000 through  
000070, 59, 63  
000100/xxxxxx, 71  
000200/xxxxxx, 71  
000300/xxxxxx, 71  
000300/000000 through  
000300/000011, 71  
000400/xxxxxx, 72  
000400/000001 through  
000400/000007, 72  
000400/000010 through  
000400/000016, 75  
0004??, 71  
000401, 64  
000500/000001 through  
000500/000324, 80

001002 through  
030050, 64  
1004xx, 49  
1004??/xxxxxx, 71  
1005xx, 50  
1006xx, 50  
1007xx, 50  
176775, 64  
177376, 64  
177710 through  
177774, 68  
177775 through  
177776, 64, 67  
177777, 67

## Topics and Error Messages

A background or system task aborted, 72  
(A/D READ) At least one bad value was  
read, 42  
Abort via directive (ABRT\$), 32  
Access to common block denied, 68  
Accessed for write, 40  
Address extensions not supported, 68  
Address window allocation overflow, 39  
Alignment error, 39  
Allocation failure, 41  
Alphabetic required, 45  
Alphanumeric required, 45  
Application dispatcher, 31  
Application exit messages, 32  
Application start-up error messages, 29

ARC11-AA analog interface, 64  
 AST abort-bad stack, 32  
 Attempt to change fixed characteristic, 43  
 Attribute control list format error, 40

Bad block on device, 41  
 Bad device name, 41  
 Bad directory syntax, 41  
 Bad dispatch, 75  
 Bad file header, 41  
 Bad file name, 41  
 Bad logical buffer, 41  
 Bad parameters, 40  
 Bad record type, 41  
 Bad tape format, 41  
 Bad version number, 41  
 Base address must be on 4k boundary, 68  
 Base mismatch common block, 67  
 Basic concepts, 5  
 Before you start, iii  
 Block check, CRC, or framing error, 41  
 Break point instruction or trace trap, 32  
 Bugcheck codes, 71  
 Bugchecks, 79  
   P/OS Server network error codes, 80

Cannot FIX a prototype task, 68  
 Cannot get taskname, 68  
 Cannot install task with resident header, 68  
 Cannot rename old file system, 41  
 Can't attach to requestor, 68  
 Can't do receive from requestor, 68  
 Can't get file LBN to process label blocks, 68  
 Can't install task CBOOT, 72  
 Can't return result parameter, 68  
 Can't spawn task CBOOT, 72  
 Can't spawn task CMAIN, 72  
 CBOOT INS error, 33  
 CBOOT system error status1 status2 status3, 33  
 Characteristic not assembled in handler, 43, 44  
 Checkpoint area too small, 68  
 Checkpoint space too small, 68  
 Codes  
   Bugcheck, 71  
   I/O success, 42  
   Primitive, 38  
   PRO/DECnet start-up failure, 75  
 Common block not loaded, 68

Common block parameter mismatch, 68  
 Common built illegally with EXTTSK option, 68  
 Common/task not in system, 68  
 Communication driver, 44  
 Completion codes, 46  
 Connection rejected, 41  
 Connection rejected by user, 41  
 Conventions used in this book, iv  
 Create directory error, 59  
 CTEX, 34  
 CTEX error, 59  
 CTI bit-map video base module, 64  
 CTI bit-map video extension, 64  
 CTI Ethernet controller, 64  
 CTI fast serial line, 64  
 CTI RD50 5-1/4" disk controller, 64  
 CTI RX50 5-1/4" disk controller, 64  
 CTI T-11 softcard, 64  
 CTI telephone management service, 64  
 CTI Z80/CMP softcard, 64  
 CTRL/C (INTERRUPT-DO) was terminator, 43  
 Customer Support Center, 8, 14, 35, 36, 37, 46, 50, 79

Data overrun, 40  
 DDM vector in use, 75  
 DECtouch module, 64  
 Device already attached, 40  
 Device full, 40  
 Device handler not resident, 39  
 Device not attachable, 40  
 Device not attached, 40  
 Device not ready, 40  
 Device off line, 41  
 Device off line when off-line request issued, 41  
 Device on line, 41  
 DIC or DPB size, or subfunction invalid, 39  
 DIGITAL Field Service representative, 14, 20  
 Directive error, 59  
 Directive inconsistent with task state, 39  
 Directive issued/not issued from AST, 39  
 Directive status word, 38  
 Disk drivers, 44  
 DLC11-AA serial interface, 64  
 DRC11-AA parallel interface, 64  
 DSR allocation failure, 75  
 DSR corrupt, 75  
 DSW, 31

- EMT trap, 72
- End-of-file detected, 40
- End-of-tape detected, 41
- End-of-volume detected, 40
- Enter-duplicate entry in directory, 41
- EOT was terminator, block mode input, 43
- ERHDN2, 30
- ERHDN3, 30
- ERNODV, 30
- ERRFND through ERROPN, 30
- Error encountered on file close operation, 68
- Error encountered on file open operation, 68
- Error from parse, 37
- Error in ASSIGN command, 59
- Error in UIC command, 59
- Error occurred
  - Accessing application, 31
  - Creating concealed logical, 30
  - Creating logical, 31
  - Creating the APPL\$NETWORK: logical, 30
  - Device not available, 30
  - Getting a command line, 31
  - Installing tasks, 30
  - Locating application, 30
  - Parsing command line, 31
  - Parsing of /NETWORK, 30
  - Parsing RMS operation, 30
  - Processing ASSIGN command, 31
  - Reading command line, 30
  - Starting task, 31
  - Using INSTALL commands, 30
- Error reporting, 8
- Error Reporting Form, 9
- Errors
  - Fatal hardware, 13
  - Hardware, 14, 20
- ERRPOI, 31
- ERRPRS, 31
- ERRPRV, 31
- ESCAPE (altmode) was terminator, 43
- Escape sequence was terminator, 43
- Event flag was clear, 39
- Event flag was set, 39
- Exit status 4. Fault code [n], 32
- Experimental ID, 64
- Experimental ID with identical bytes, 64
- Expressions are of different types, 37
- Extraneous information in the script file, 37

- Failure
  - Hardware, 14
  - Power-up, 15
- Fatal hardware error on device, 41
- Fatal hardware errors, 13
- FBI error (Fmt/Bad/Ini), 59
- File already accessed on LUN, 40
- File already open, 41
- File buffer space unavailable, 40
- File exceeds space allocated, no blocks, 41
- File header checksum failure, 40
- File header full, 40
- File ID, file number check, 40
- File ID, sequence number check, 40
- File ID was not specified, 41
- File not found, 67
- File not task image, 68
- File processor device read error, 40
- File processor device write error, 40
- File was not properly closed, 40
- Floating Point Processor, 63
- Floppy disk successful completion, 42
- FMS-11 messages, 45
- Full field required, 45

- Hardware
  - Fatal errors, 13
  - Nonfatal errors, 20
- Hardware errors, 8
- Hardware failures PC300 family, 16
- Hardware illustrations, 53
- Hardware option not present, 40
- Hardware power-up failure, 20

- IBM COMM Data read was result of IBM host chained-write operation, 42
- IDLDR IEEE option, 64
- IE.2DV through IE.WOV, 40, 41
- IF operator invalid for expression(s) type, 38
- Illegal characteristic name, 43
- Illegal device, 68
- Illegal first APR, 68
- Illegal IF operator, 38
- Illegal instruction trap, 71
- Illegal mapping specified, 39
- Illegal operation on file descriptor block, 41
- Illegal or reserved instruction, 32
- Illegal overlay request, 40
- Illegal record access bits set, 41

- Illegal record attribute bits set, 41
- Illegal record number-too large, 41
- Illegal record size, 41
- Illegal sequential operation, 41
- Illegal UIC, 68
- Illegal use of partition or region, 68
- Illegal user buffer, 40
- Illegal value for binary characteristic, 43
- Illegal vector specified, 39
- Index file full, 40
- Information in this book, 3
- Input and output (I/O) error messages, 40
- Input required, 45
- Insufficient dynamic storage, 39
- Insufficient dynamic storage for send, 39
- Intended audience, iii
- Interface does not have settable characteristics, 43
- INTERNAL Buffer overflow, 38
- Internal consistency error, 41
- Internal errors, 59
- Invalid address window ID, 39
- Invalid AST address specified, 43
- Invalid command, 38
- Invalid device or unit, 39
- Invalid escape sequence, 41
- Invalid event flag, 39
- Invalid expression syntax, 38
- Invalid function code, 40
- Invalid LUN, 39
- Invalid or contradictory qualifier, 38
- Invalid parity type for interface, 43
- Invalid priority, 39
- Invalid region ID, 39
- Invalid request, 68
- Invalid send buffer size, 39
- Invalid speed for interface, 43
- Invalid split speed for interface, 43
- Invalid table number, 39
- Invalid task name, 38
- Invalid terminal type, 43
- Invalid TI parameter, 39
- Invalid time parameters, 39
- Invalid UDC module number, 40
- Invalid UIC, 39
- Invalid value for nonbinary characteristic, 43
- I/O
  - Communication driver, 44
  - Directive status word (DSW), 38
  - Disk drivers, 44
  - Success codes, 42
- I/O full-word subcodes, 42
- I/O high-byte subcodes in communication driver, 44
- I/O high-byte subcodes in terminal driver, 43
- I/O request pending, 44
- I/O standard success codes, 42
- I/O status for communication driver, 44
- I/O status for disk drivers, 44
- I/O subcodes
  - IS.SUC (terminal driver), 42
- IOT in system state, 71
- IOT instruction, 32
- IS.BV through IS.TNC, 42-44
- Issuing task not checkpointable, 39
- IVIS base module set, 64
- IVIS bit-map base module, 64
- IVIS bit-map video extension, 64
- IVIS system module, 64
  
- Kanji font module, 64
- Keyboard SR error, 59
  
- LB:[ZZSYS]KBTTAB.DAT, 50
- LED errors
  - PC300, 16
  - PC325, 18
  - PC350, 18
  - PC380, 19
- Length mismatch common block, 67
- LK200 Keyboard, 63
- LK200 Keyboard Control, 63
- Locked from read/write access, 40
- Logical block number too large, 40
- Logical name not found, 39
- Logical name superseded, 39
- Login script file processor messages, 37
- LUN locked in use, 39
  
- Main menu, 29
- Maintenance services diagnostics, 13
- Materials service, 14
- Media inserted incorrectly, 44
- Memory protect violation, 32
- Message error, 59
- Messages
  - Base system, 29
  - Input and output, 40
  - Login script file processor, 37
  - Main menu, 29
- MRC11-AA ROM option, 64

No AST specified in connect, 41  
 No checkpoint space, 68  
 No dynamic space available, 41  
 No equivalence name supplied, 38  
 No file accessed on LUN, 40  
 No help available, 45  
 No logical name supplied, 38  
 No pool space, 68  
 No space to save default characteristics, 43  
 No such file, 40  
 No such node, 41  
 No swap space available, 39  
 No task name specified, 38  
 No way to boot via DECNA, 75  
 Non-displayable character, 45  
 Non-RSX EMT instruction, 32  
 Nonfatal errors, 20  
 Not a network LUN, 41  
 Not ANSI 'D' format byte count, 41  
 Not enough APRs for task image, 68  
 Not enough stack space (FCS or FCP), 41  
 Numeric required, 46

Odd address and other traps to 4, 32  
 Odd address or other trap to 4, 71  
 Odd byte count or virtual address, 40  
 OEM sales representative, 14, 20  
 Operation complete, success, 42, 44  
 Operation pending, 42, 44  
 Other invalid line parameters, 43

Parity error on device, 40  
 Part of DPB out of user's space, 39  
 Partial escape sequence, 41  
 Partial escape sequence terminator, 43  
 Partition busy, 68  
 Partition too small for task, 39  
 Partition/region not in system, 39  
 Path lost to partner, 41  
 PC300 family hardware failures, 14  
 PC300 family LED error codes, 16  
 PC325 and PC350 LED error codes, 18  
 PC380 LED error codes, 19  
 (PCL) Successful transfer but message truncated, 42  
 Plug boot block error, 59  
 Pool allocation failure, 72  
 P/OS bugcheck codes, 71  
 P/OS drivers, 42  
 P/OS executive, general, 71

P/OS keyboard handler, 71  
 P/OS terminal subsystem, 71  
 POSSUM error, 31  
 POSSUM service error, 59  
 Primitive error codes, 38  
 Privilege violation, 39  
 Privilege violation or device not mounted, 40  
 PRO 300 Base Processor, 63  
 PRO 300 Communication Port, 63  
 PRO 300 Diag/ROM Version 1.0, 63  
 PRO 300 Diag/ROM Version 2.0, 63  
 PRO 300 DMA test module, 64  
 PRO 300 Interrupt Controller, 63  
 PRO 300 Maintenance Console Port, 63  
 PRO 300 Monitor Attachment, 63  
 PRO 300 Nonvolatile Memory, 63  
 PRO 300 Option Present Register, 63  
 PRO 300 Option RAM, 63  
 PRO 300 Primary RAM, 63  
 PRO 300 Printer Port, 63  
 PRO 300 Serial Number ROM, 63  
 PRO 300 Speaker Control, 63  
 PRO 300 Time/Date Clock, 63  
 PRO 380 Base Processor, 63  
 PRO 380 base system ROM version 1.0, 64  
 PRO 380 bit-map extension and color map, 64  
 PRO 380 bit-map video base module, 64  
 PRO 380 bit-map video extension, 64  
 PRO 380 Interrupt Controller, 63  
 PRO/DECnet start-up failure codes, 75  
 PROTSK, 67

Receive buffer is too small, 39  
 Region or common fixed, 68  
 Rename—file name already in use, 41  
 Rename—two different devices, 41  
 Request terminated, 40  
 Required hardware not present, 75  
 Required PDV not found, 75  
 Required reading, iii  
 Required start-up file not found or not executable, 72  
 Resource in use, 39  
 RETURN was terminator, 43  
 RMS-11, 46  
   Completion codes, 46  
 RMS-11 error, 59  
 RMSIFL (RMS-11 Indexed File Load Utility) Messages, 46

- SE.ATA through SE.VAL, 43, 44
- Segment fault, 71
- Send/receive failure, 40
- Service contract, 14
- Setup/reset error, 59
- Shareable resource in use, 40
- Signed numeric required, 46
- Software application errors, 8
- Software messages, 29
- Specified partition too small, 67
- Specified task not installed, 39, 41
- SST abort–bad stack, 32
- Stack overflow, 71
- Success, request timed out, 44
- Successful but with data overrun, 42
- Successful completion, 44
- Successful completion on read terminated, 42
- Successful install, 67
- Syntax error, 38
- System boot failure, 32
- System boot procedure error codes, 32
- System dynamic memory, 40
- System hardware failure, 20
- System installation error codes, 59
- System service start-up error codes, 31
- System start-up processing, 72
  
- Task active, 68
- Task already fixed/unfixed, 39
- Task and partition base mismatch, 67
- Task being fixed, 68
- Task checkpoint read failure, 32
- Task exit with outstanding I/O, 32
- Task fixed, 68
- Task image already installed, 68
- Task image I/O error, 68
  
- Task image virtual address overlaps common block, 68
- Task is checkpointable, 39
- Task load read failure, 32
- Task may not be run, 68
- Task name in use, 67
- Task not active, 39
- Task not linked to specified ICS/ICR interrupts, 41
- Task requested abort, 32
- Task was suspended, 39
- Tempest keyboard, 64
- Terminal attached with AST notification, 43
- Terminal driver, 71
  - High-byte subcodes, 43
- Terminal input error, 59
- Terminal not attached, 43
- Terminal output error, 59
- Terminal subsystem, 8, 49
- Time service, 14
- Too many common block requests, 67
- Too many LUNs, 68
- Too many outstanding messages, 41
- Trace trap or breakpoint, 71
- Trap instruction, 32
- TRAP trap, 72
  
- UDC connect error, 40
- Unable to create or map to region, 68
- Unassigned LUN, 39
- Unlock error, 41
- Unready Option, 63
- Unsuccessful completion to a timeout, 44
  
- Window has I/O in progress, 39
- Write attempted to locked unit, 40
- Write check failure, 41

### READER'S COMMENTS

Did you find this manual understandable, usable, and well-organized? Please make suggestions for improvement.

---

---

---

---

---

Did you find errors in this manual? If so, specify the error and the page number.

---

---

---

---

---

Please indicate the type of reader that you most nearly represent.

- First-time computer user
- Experienced computer user
- Application package user
- Programmer
- Other (please specify) \_\_\_\_\_

Name \_\_\_\_\_

Date \_\_\_\_\_

Organization \_\_\_\_\_

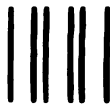
Street \_\_\_\_\_

City \_\_\_\_\_

State \_\_\_\_\_

Zip Code  
or Country \_\_\_\_\_

**digital**

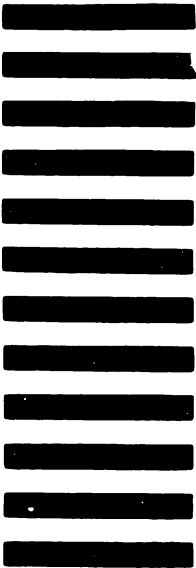


No Postage  
Necessary  
if Mailed in the  
United States

**BUSINESS REPLY MAIL**  
FIRST CLASS PERMIT NO 33 MAYNARD MASS

POSTAGE WILL BE PAID BY ADDRESSEE

ATTN: Professional Workstations Publications  
DIGITAL EQUIPMENT CORPORATION  
146 MAIN STREET ML021-2/T76  
MAYNARD, MA 01754-2571



Do Not Tear - Fold Here

Cut Along Dotted Line

Printed in Holland  
AA-FC89A-TH