

EK-R100E-OM-001

*Rainbow*TM

Owner's Manual

digital equipment corporation

First Edition, September 1983

© Digital Equipment Corporation 1983. All Rights Reserved.

The information in this document is subject to change without notice and should not be construed as a commitment by Digital Equipment Corporation. Digital Equipment Corporation assumes no responsibility for any errors that may appear in this document.

WARNING: The Rainbow computer has been certified to comply with the limits for a Class B computing device, pursuant to Subpart J of Part 15 of FCC Rules. Only peripherals (computer input/output devices, terminals, printers, etc.) certified to comply with the Class B limits may be attached to this computer. Operation with noncertified peripherals is likely to result in interference to radio and television reception.

This equipment generates and uses radio frequency energy and if not installed and used properly, that is, in strict accordance with the manufacturer's instructions, may cause interference to radio and television reception. It has been type tested and found to comply with the limits for a Class B computing device in accordance with the specifications in Subpart J of Part 15 of FCC Rules, which are designed to provide reasonable protection against such interference in a residential installation. However, there is no guarantee that interference will not occur in a particular installation. If this equipment does cause interference to radio or television reception, which can be determined by turning the equipment off and on, the user is encouraged to try to correct the interference by one or more of the following measures:

- reorient the receiving antenna
- move the computer away from the receiver
- plug the computer into a different outlet so that computer and receiver are on different branch circuits.

If necessary, the user should consult the dealer or an experienced radio/television technician for additional suggestions. The user may find the following booklet prepared by the Federal Communications Commission helpful:

How to Identify and Resolve Radio-TV Interference Problems

This booklet is available from the US Government Printing Office, Washington, DC 20402.
Stock No. 004-000-00345-4.

The manuscript for this book was created using a DIGITAL Word Processing System and, via a translation program, was automatically typeset on DIGITAL's DECset Integrated Publishing System. Book production was done by Educational Services Development and Publishing in Marlboro and Bedford, MA.

The following are trademarks of Digital Equipment Corporation:

digital	DIBOL	RSX
DEC	MASSBUS	UNIBUS
DECmate	PDP	VAX
DECsystem-10	P/OS	VMS
DECSYSTEM-20	Professional	VT
DECUS	Rainbow	Work Processor
DECwriter	RSTS	

Printed in U.S.A.

Contents

Preface xi

Chapter 1. Your Rainbow Computer 1

The Rainbow Computer 1
Easy-to-Use Components 2
The Monitor 3
The Keyboard 4
The System Unit 6
The Dual-Diskette Drive 12

Chapter 2. The Rainbow Keyboard 15

Introduction 15
Standard Keys 16
Editing and Cursor Control Keys 16
Numeric Keypad Keys 17

- Function Keys 17
- Compose Character Sequences 20
- Keyboard Indicator Lights 21
- Character Coding 22
- Changing the Keyboard/Language 23

Chapter 3. Selecting Computer Features Using Set-Up 25

- Introduction 25
- Entering Set-Up to Change Features 26
- Help 28
- Default Set-Up Values 29
- Tabs Major Heading 29
- Parameter Settings Major Heading 31
- Modem Major Heading 44
- Printer Major Heading 46
- Miscellaneous Major Heading 48
- Auto-Boot Major Heading 49
- Saving Set-Up Values 50
- Recalling Set-Up Values 50
- System Reset 51

Chapter 4. Connecting a Printer to Your Rainbow Computer 53

- Introduction 53
- Connecting a Printer 54
- Printer Set-Up Selections 56
- Printer Connector Signals 58
- Using the Printer with a Remote Computer 59
- Print Keys 59
- Print Commands 60

Chapter 5. Communicating with Another Computer 61

- Introduction 61
- Connecting the Rainbow Computer to a Remote Computer 62
- Changing Rainbow Set-Up Features to Communicate with a Remote Computer 65
- The Modem Protocol Set-Up Feature 67
- Auto-XON/XOFF 70
- Transmit Break 71
- Communications Connector Signals 71
- Using Terminal Mode 74

Chapter 6. Rainbow Computer Tests 77

- Diagnostic Tests 77
- Internal Diagnostic Test – Selftest 77
- Diskette Diagnostic Test 83

Chapter 7. Troubleshooting 91

- Introduction 91
- Troubleshooting Procedure 91

Appendix A. Rainbow Computer Specifications

Appendix B. Rainbow Messages

Appendix C. Rainbow Parts List and Reference Manuals

Appendix D. International Language Keyboards

Appendix E. Compose Sequences

Appendix F. 7-bit/DEC 8-bit Translations

Appendix G. Options

Appendix H. Rainbow Control Functions

Glossary

Index

Figures

- 1-1. Rainbow Computer 2
- 1-2. The Monitor 3
- 1-3. The Keyboard 5
- 1-4. The System Unit 6
- 1-5. Removal of Dual-Diskette Drive 7
- 1-6. System Unit, Back View 8
- 1-7. System Module Removal 9
- 1-8. System Module 9
- 1-9. Division of System Functions 10
- 1-10. Dual-Diskette Drive 12
- 1-11. Inserting a Protective Card 13

2-1.	Rainbow Keyboard	16
2-2.	Standard Keys	17
2-3.	Editing and Cursor Control Keys	17
2-4.	Numeric Keypad Keys	18
2-5.	Function Keys	18
2-6.	Keyboard Indicator Lights	21
2-7.	Keyboard Selection Menu	23
3-1.	Set-Up Key Location	26
3-2.	First Set-Up Display	27
3-3.	Set-Up Screen Components	27
3-4.	Set-Up Display – Tabs	30
3-5.	Set-Up Display – Parameter Settings	32
3-6.	Summary of Parameter Settings	33
3-7.	Auto-Screen Blank Phantom Cursor	38
3-8.	Set-Up Display – Auto-Answerback	43
3-9.	Set-Up Display – Modem	45
3-10.	Set-Up Display – Printer	47
3-11.	Set-Up Display – Miscellaneous	48
3-12.	Set-Up Display – Auto-Boot	50
4-1.	Digital's Personal Printers	53
4-2.	Printer Connector on the System Unit	54
4-3.	Connecting the COMM Cable to the Printer Connector	55
4-4.	Set-Up Mode Showing Printer Heading	56
4-5.	Print Keys	59
5-1.	Rainbow Computer and Remote Computer Connection	62
5-2.	Direct Connection	63
5-3.	Telephone Line Connection	64
5-4.	Connecting the COMM Cable to the Connector	66
5-5.	Connecting the COMM Cable to a Remote Computer Cable	66
5-6.	COMM Pin Numbers	72
5-7.	Rainbow Main System Menu	75
5-8.	Standard Keys Used in Terminal Mode	75
5-9.	Function Keys Used in Terminal Mode	76
5-10.	Print Keys Used in Terminal Mode	76
6-1.	Main System Menu	78
6-2.	Main System Menu with Message	79
6-3.	Example of a Message Displayed on the Lights at the Back of the System Unit	79
6-4.	Blank Diskettes	80
6-5.	Insert Diskettes into Drives A and B	82
6-6.	Main Diagnostic Menu	84

- 6-7. Drives A and B Test Messages 85
- 6-8. Test Computer Messages 86
- 6-9. Individual Test Menu 87
- B-1. Example of a Light Display on the Back of the System Unit 104
- D-1. LK201-AA American (English) Keyboard 130
- D-2. LK201-AB Belgian/Flemish Keyboard 130
- D-3. LK201-AC Canadian (French) Keyboard 130
- D-4. LK201-AD Danish Keyboard 131
- D-5. LK201-AE British Keyboard 131
- D-6. LK201-AF Finnish Keyboard 131
- D-7. LK201-AG Austrian/German Keyboard 132
- D-8. LK201-AH Dutch Keyboard 132
- D-9. LK201-AI Italian Keyboard 132
- D-10. LK201-AK Swiss (French) Keyboard 133
- D-11. LK201-AL Swiss (German) Keyboard 133
- D-12. LK201-AM Swedish Keyboard 133
- D-13. LK201-AN Norwegian Keyboard 134
- D-14. LK201-AP Belgian/French Keyboard 134
- D-15. LK201-AS Spanish Keyboard 134
- E-1. Compose Sequences 135
- F-1. Mapping Keyboard to National Replacement Characters 137
- F-2. 7-bit/DEC 8-bit Translations 138
- F-3. DEC Multinational Character Set (DEC 8-bit) 139
- F-4. Dutch Character Set (7-bit) 140
- F-5. Finnish Character Set (7-bit) 141
- F-6. French Canadian Character Set (7-bit) 142
- F-7. French Character Set (7-bit) 143
- F-8. German Character Set (7-bit) 144
- F-9. Italian Character Set (7-bit) 145
- F-10. Norwegian/Danish Character Set (7-bit) 146
- F-11. Spanish Character Set (7-bit) 147
- F-12. Swedish Character Set (7-bit) 148
- F-13. Swiss Character Set (7-bit) 149
- F-14. United Kingdom Character Set (7-bit) 150

Tables

- 3-1. Keys Used to Move Through Set-Up 28
- 3-2. How to Change Tab Stops 31
- 3-3. Lock Mode on the Swiss (German) Keyboard 41
- 3-4. Modem and Printer Data Bits and Parity Selection 45
- 3-5. Modem Protocols 46
- 3-6. Baud Rates for Digital's Personal Printers 48
- 4-1. Printer Data Bits and Parity Selections 57
- 4-2. Printer Connector Signals 58
- 5-1. Communications Protocols 68
- 5-2. Modem Connect Conditions 69
- 5-3. Communications Connector Signals 72
- 7-1. Troubleshooting Procedure 92
- B-1. Internal Diagnostic Test Messages 105
- B-2. Diskette Diagnostic Test Messages 119
- C-1. Rainbow Parts List 126
- C-2. Reference Manuals 128
- H-1. Set-Up Features and Modes 162
- H-2. ANSI-Specified Modes 164
- H-3. ANSI-Compatible Private Modes 164
- H-4. Permanently Selected Modes 165
- H-5. Line Feed/New Line Feature 175
- H-6. ANSI Cursor Control Key Codes 178
- H-7. ANSI Keypad Codes 180

Preface

This *Rainbow™ Owner's Manual* briefly describes the hardware components of your Rainbow computer and presents the Set-Up features that allow you to adapt the computer to your needs.

Before reading this manual, use the *Rainbow™ Installation Guide* to help you install the computer.

The manual is divided into the following chapters and appendices.

- **Chapter 1, Your Rainbow Computer**, describes the basic components of the Rainbow computer.
- **Chapter 2, The Rainbow Keyboard**, discusses the different key groupings and special keyboard features.
- **Chapter 3, Selecting Computer Features Using Set-Up**, describes the Rainbow features that you can change by using the **Set-Up** key.
- **Chapter 4, Connecting a Printer to Your Rainbow Computer**, describes the connections, Set-Up selections, and signals used when you connect a printer to the Rainbow computer.

- **Chapter 5, Communicating with Another Computer**, describes how to connect your Rainbow computer to another computer, which Set-Up features to select, and the signals used when communicating with another computer.
- **Chapter 6, Rainbow Computer Tests**, discusses the internal diagnostic tests and the diskette diagnostic tests that verify that the system is working correctly.
- **Chapter 7, Troubleshooting**, lists symptoms of problems that may occur, their possible causes, and the actions you can take to correct them.
- **Appendix A, Rainbow Computer Specifications**, summarizes the Rainbow computer's hardware specifications.
- **Appendix B, Rainbow Messages**, lists the messages that may appear during system and diagnostic testing and the actions you can take to correct their causes.
- **Appendix C, Rainbow Parts List and Reference Manuals**, lists user-replaceable parts of the Rainbow and the manuals that refer to the Rainbow computer.
- **Appendix D, International Language Keyboards**, illustrates the keyboards available in different countries.
- **Appendix E, Compose Sequences**, lists the sequences of keys you type to compose special characters.
- **Appendix F, 7-bit/DEC 8-bit Translation**, lists the National Replacement Character (NRC) sets for the different country keyboards.
- **Appendix G, Options**, lists the options available for your Rainbow computer.
- **Appendix H, Rainbow Control Functions**, describes the control and escape techniques you can use with your Rainbow computer.

At the end of the manual you will find a Glossary and an Index.

The keys on the Rainbow keyboard that are mentioned in text appear in bold-face (for example, press the **Shift** key). Note that **Return** represents the **Return** key, and to press **Shift/A** means to hold down the **Shift** key and press the **A** key at the same time. User responses are in color when they appear in computer dialog.

Your Rainbow Computer

The Rainbow Computer

The Rainbow computer, shown in Figure 1-1, consists of the following.

- Monitor
- Keyboard
- System unit

The system unit contains the following.

- Dual-diskette drive
- Power supply
- System module
- Fan and switch assembly

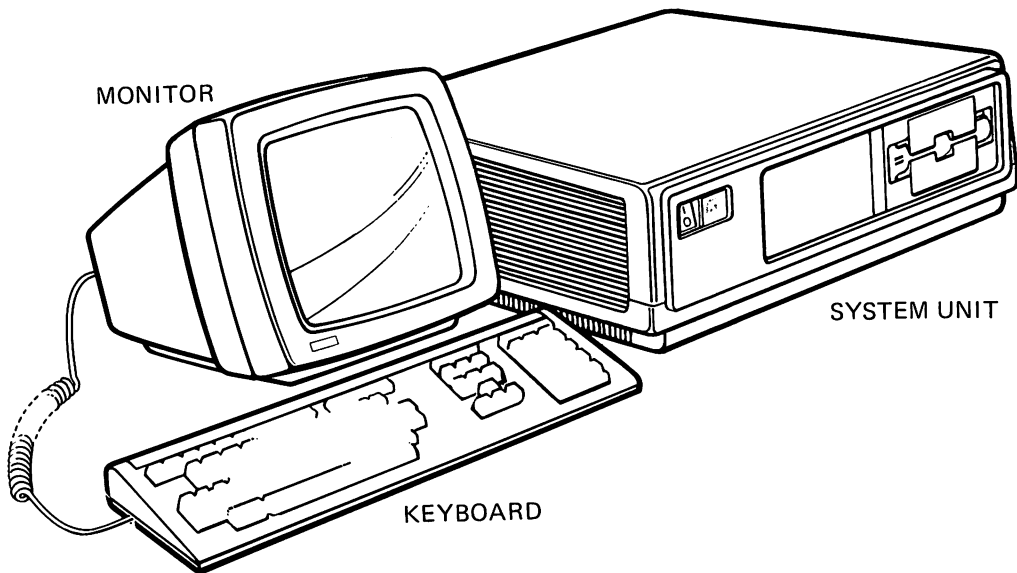

Figure 1-1. Rainbow Computer

Easy-to-Use Components

The Rainbow computer's design makes the computer easy to install, comfortable to operate, and simple to repair. Digital Equipment Corporation designed the computer so that conditions that might lead to strain and fatigue are minimized. The computer is also flexible so that you have the freedom to adapt it to your needs.

The components of the Rainbow computer are light, compact, and portable so you can place the components in many locations. You can use the optional floor stand to hold the system unit and keep your work surfaces clear. The keyboard comes with a 1.8 m (6 ft) cord that lets you place the keyboard anywhere comfortable.

See Appendix A for a summary of the Rainbow computer's specifications.

The Monitor

The monitor, shown in Figure 1-2, has a video screen that measures 30.5 cm (12 inches) diagonally and is coated to reduce glare. Fingerprints show up very easily. When necessary, clean the screen with a lint free cloth and a screen cleaner.

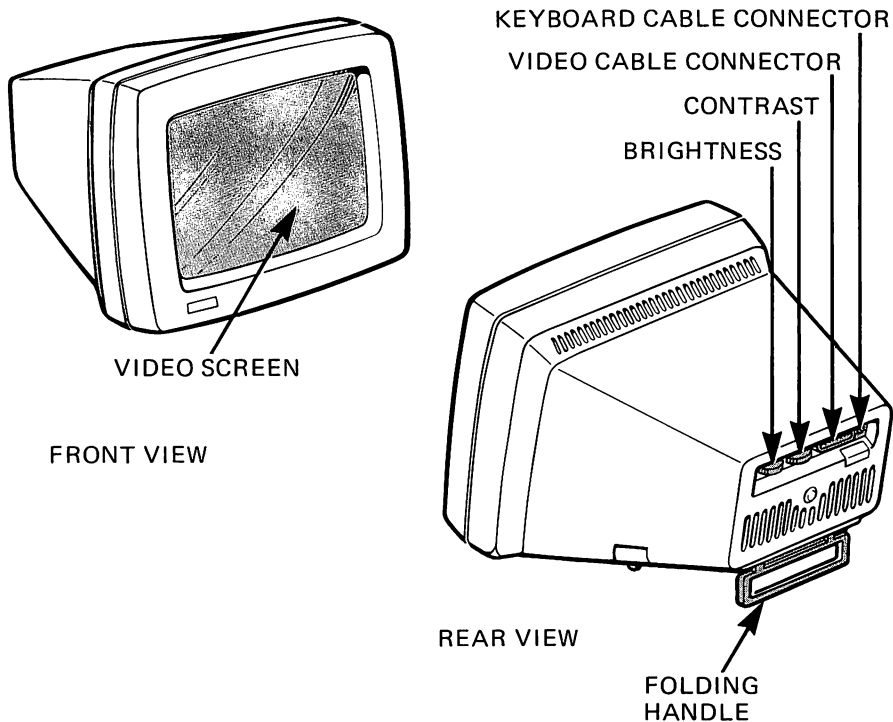

Figure 1-2. The Monitor

Video information and the internal connection for the keyboard are supplied by the monitor. The monitor has the following features.

- 24-line × 80- or 132- column display
- Jump or smooth scrolling
- Double-height characters (by line)

- Double-width characters (by line)
- Normal and reverse video (by character)
- Boldface, blinking, and underlined characters (by character)
- Dark or light screen background
- Auto-screen blanking
- Brightness and contrast controls

The Keyboard

The Rainbow keyboard, shown in Figure 1-3, is designed to help you do your work easily. There are fifteen different language keyboards available for use in different countries.

The keyboard includes the following extra features.

- A low profile that takes up less space.
- Keyclicking that sounds as you press the keys. You can adjust the keyclick volume or turn it off.
- A keyboard tone generator that produces a margin bell. You can also adjust the bell volume.
- Auto-repeat, a repeated display of all keys you press on the main keypad array, the numeric keypad, and the function keys.
- Keyboard lights that the computer can turn on and off to indicate various conditions during operation.
- A **Compose Character** key that allows you to generate characters not shown on the keyboard.
- A **Set-Up** key that allows you to change several Rainbow computer features.

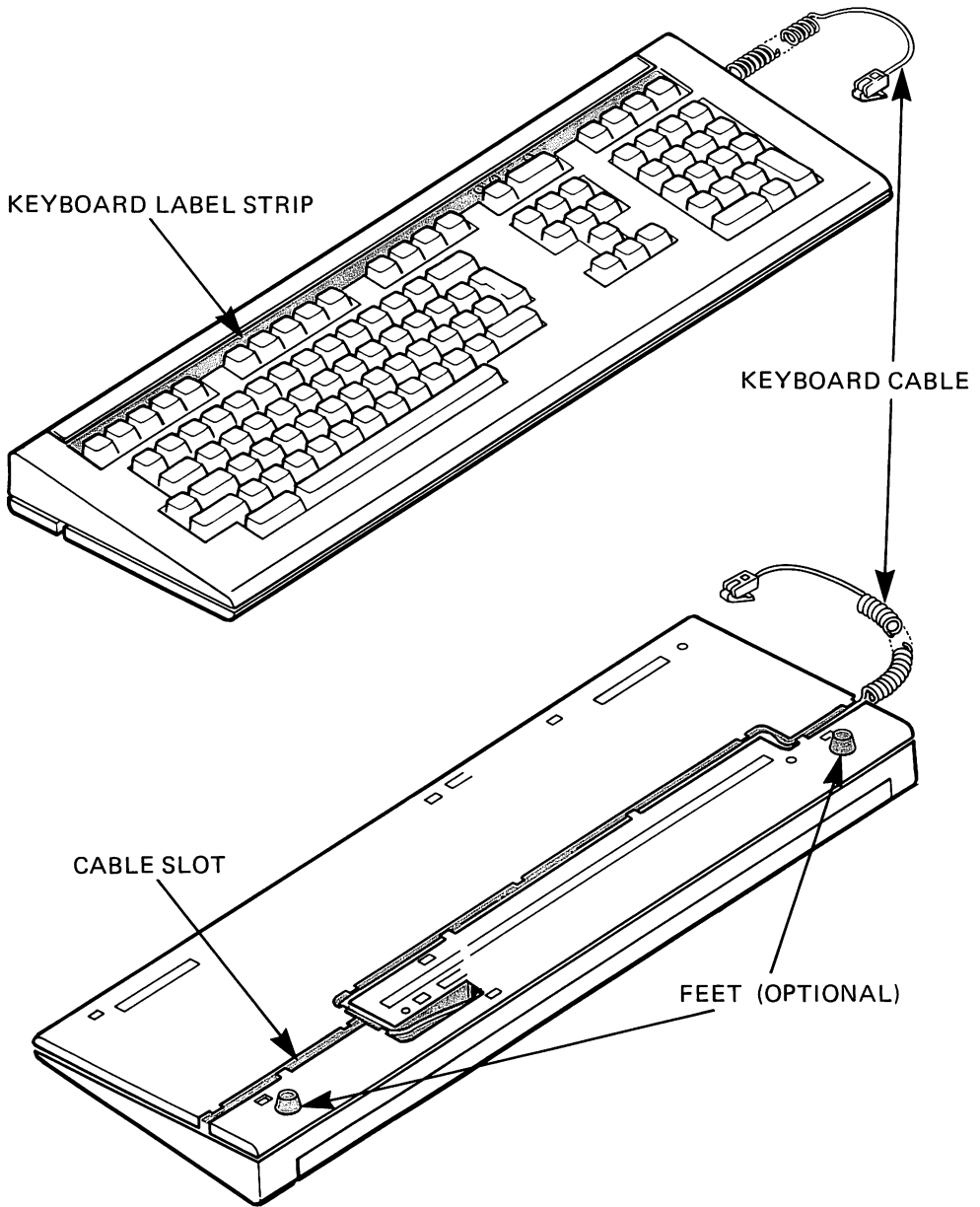

Figure 1-3. The Keyboard

The System Unit

You can place the system unit, shown in Figure 1-4, horizontally on a desk or vertically in the optional floor stand. Placing the system unit in the floor stand gives you more desk space. The system unit contains the following:

- Dual-diskette drive
- Power supply
- System module
- Fan and switch assembly

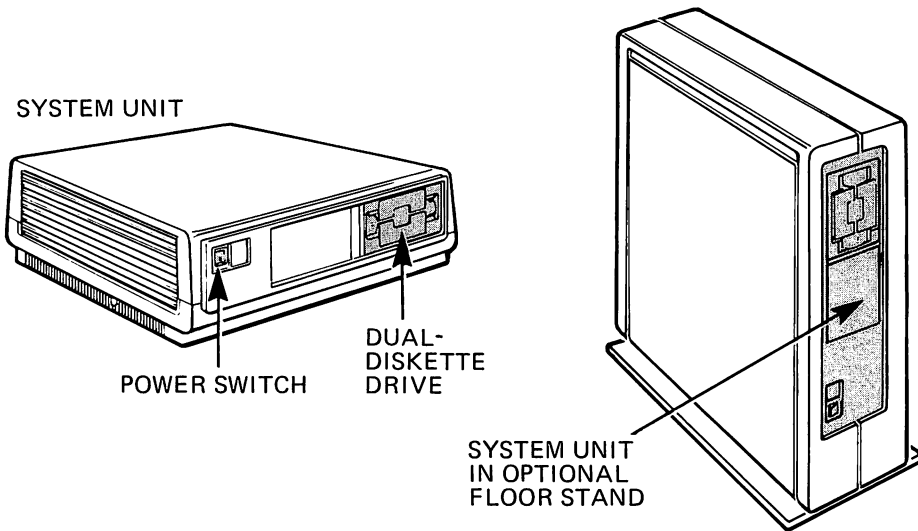

Figure 1-4. The System Unit

The design of the system unit components makes the maintenance and installation of options easy. The system unit's cover is secured by two cover release tabs under its sides. You can remove the dual-diskette drive (Figure 1-5) and the power supply by disconnecting their cables and releasing their latches.

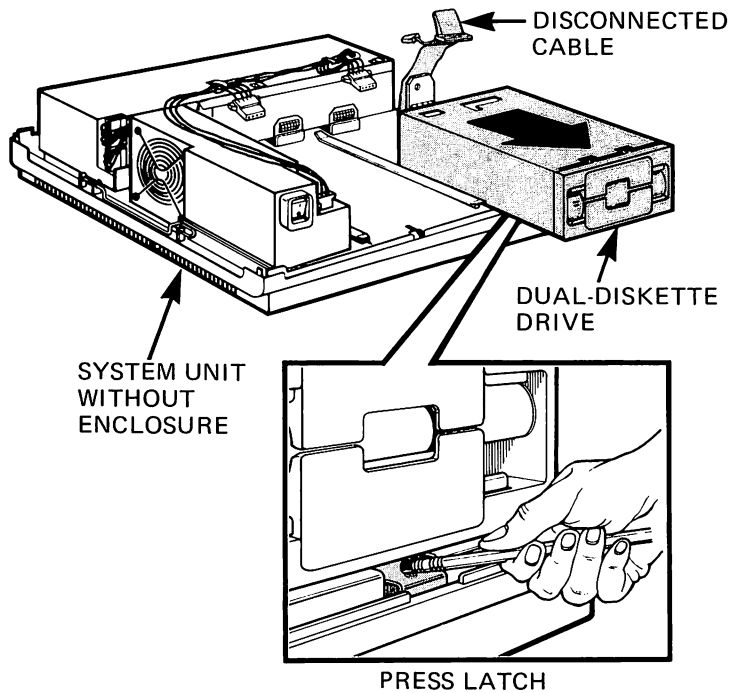

Figure 1-5. Removal of Dual-Diskette Drive

The connectors for power and peripheral devices are on the back of the system unit, shown in Figure 1-6. The unique design of the connectors, which are labeled as follows, prevents misconnections.

- COMM (for an optional communications line)
- PRINTER (for the printer cable)
- VIDEO (for the monitor cable)

The seven lights on the back of the system unit indicate the source of most problems that can occur with the computer. These lights provide a backup to messages displayed on the screen and are useful should the monitor fail.

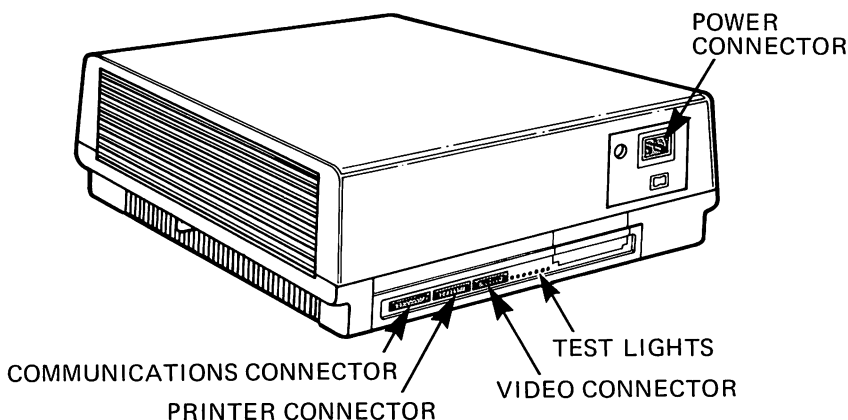

Figure 1-6. System Unit, Back View

The System Module

The system module, located inside the system unit, slides out of the back of the system unit. (See Figure 1-7.)

This module has connectors on it for mounting the RX50 dual-diskette drive controller board and options such as an additional memory board, an extended communications board, a color/graphics board, and a controller for a hard disk. It also has connectors for a communications line, a printer, and video. The system module is made up of electrical components and circuits. (See Figure 1-8.)

The system module uses a Z80[®]A 8-bit processor coupled with an 8088 16-bit processor. Computer functions are divided between these two processors as shown in Figure 1-9. The Z80A processor controls the dual-diskette drive's reading and writing of data, while the 8088 processor controls the monitor, the keyboard, the communications connector, and all options added to the computer.

There are 128K (131,072) bytes of main memory. (A byte is the amount of memory required to store one character.) This memory can be expanded by adding optional memory. The system module also has a 32K byte ROM that contains diagnostic tests, a bootstrap program, the terminal mode programs, and language translation. The dual-diskette drive contains auxiliary storage.

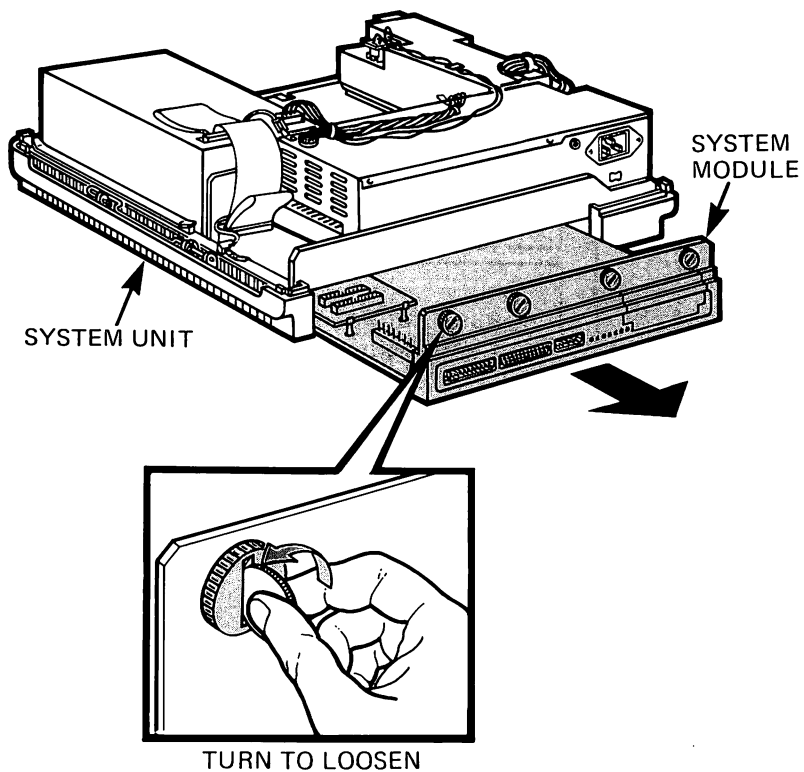

Figure 1-7. System Module Removal

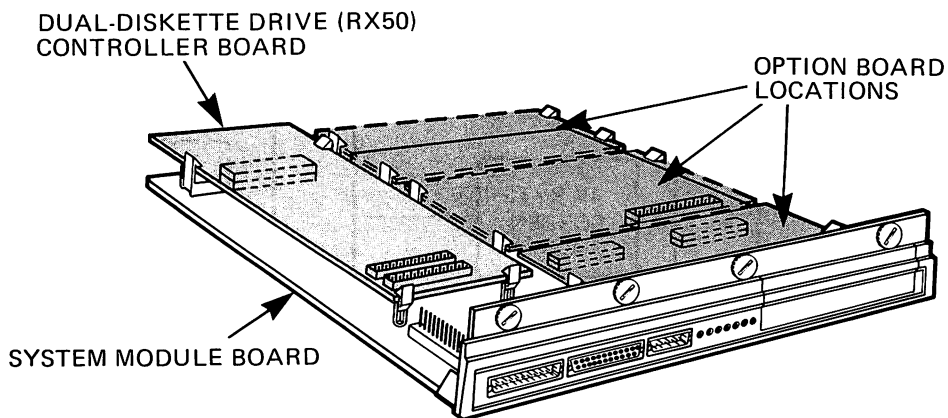

Figure 1-8. System Module

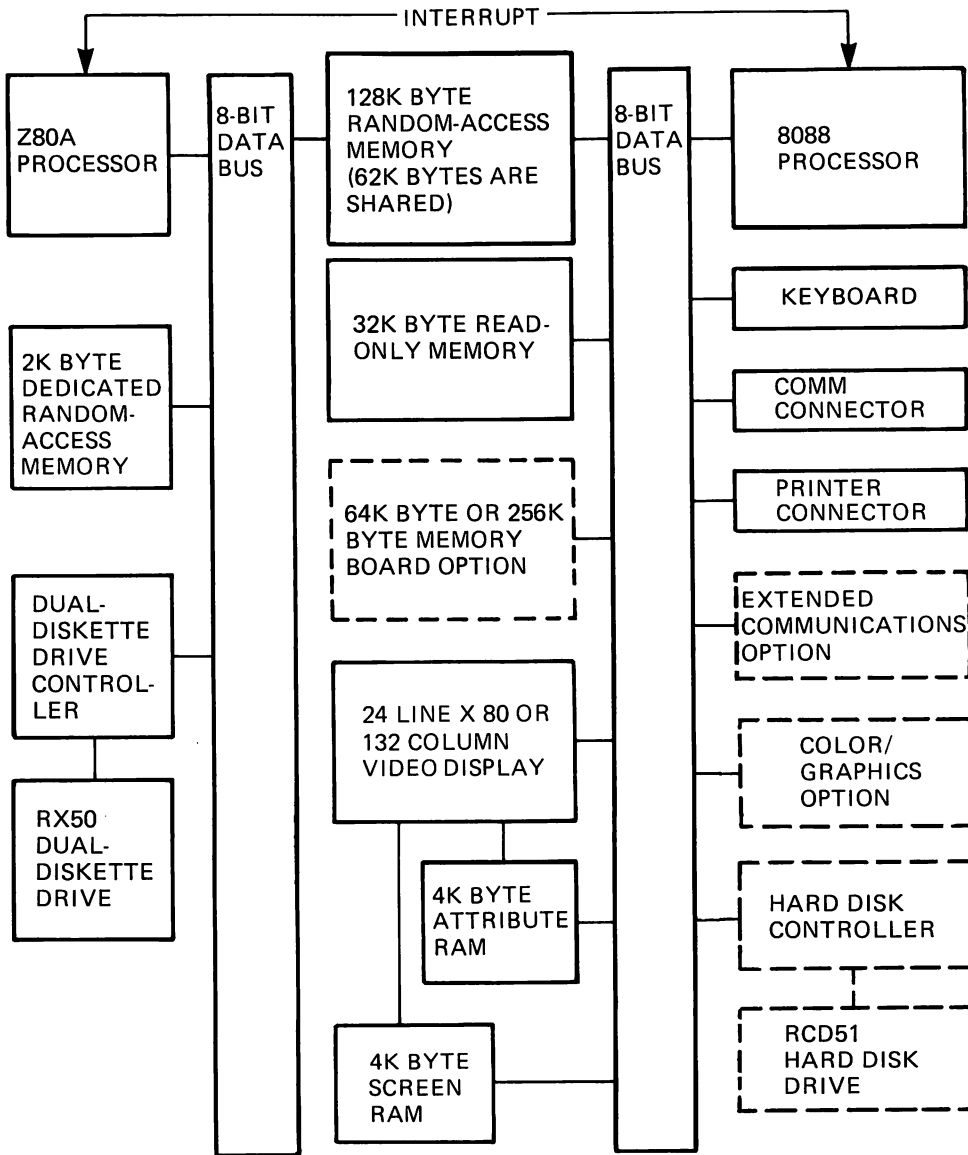

Figure 1-9. Division of System Functions

Communications Connector

The communications connector (labeled COMM on the back of the system unit) can be connected, directly or through a modem, to another computer. (Modems are used to communicate with another computer over a telephone line.) Refer to Chapter 5, *Communicating with Another Computer*, for information on communications connections.

Printer Connector

You use the printer connector (labeled PRINTER on the back of the system unit) to connect a printer to your Rainbow computer. The following three printers are available from Digital Equipment Corporation for its personal computers.

- LA50 Personal Printer
- LA100 Letterprinter 100
- LQP02 Letter-Quality Printer

You can also use any other serial printer with the same FCC classification (Class B) that either supports XON/XOFF synchronization or uses the data terminal ready (DTR) line to indicate printer availability. (See Chapter 4, *Connecting a Printer to Your Rainbow Computer*.)

Video Connector

The video connector (labeled VIDEO on the back of the system unit) connects the monitor to the system unit.

The Dual-Diskette Drive

The Rainbow computer's compact diskette subsystem consists of:

- The RX50 controller module, located on the system module
- The RX50 dual-diskette drive (see Figure 1-10)
- A second (optional) dual-diskette drive.

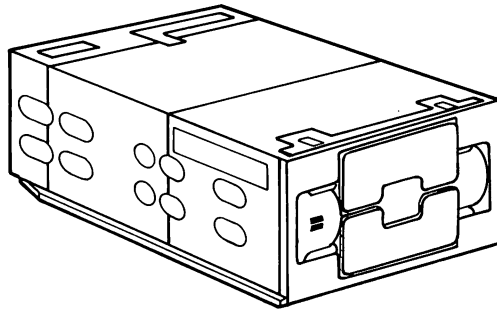

Figure 1-10. Dual-Diskette Drive

The diskettes provide mass storage, data exchange, and file backup capabilities. Each drive stores 400K bytes of information on 5 1/4 inch diskettes. You can add a second dual-diskette drive to the computer to provide additional mass storage. You can also add a hard disk drive for additional mass storage.

Each drive has two sensors that detect when a diskette is installed. These sensors also look for the notch on the side of the diskette's protective cover to see if the diskette is write-protected. If this notch is covered, the drive cannot write on the diskette.

IMPORTANT

The dual-diskette drive comes with a protective card installed to keep the drive's carriage stable during shipment. Save the card and reinstall it every time you move the system unit or pack it for shipment. You install the protective card as follows.

1. Open the door of drive A (and drive C, if present).
2. Remove any diskette(s) from the drive(s).
3. Turn on the power and wait for a bell tone to sound from the keyboard.
4. Turn off the power.
5. Insert the protective card into drive A (and drive C, if present) as shown in Figure 1-11.
6. Close the door of the drive(s).

Refer to Appendix A for a summary of the dual-diskette drive's specifications.

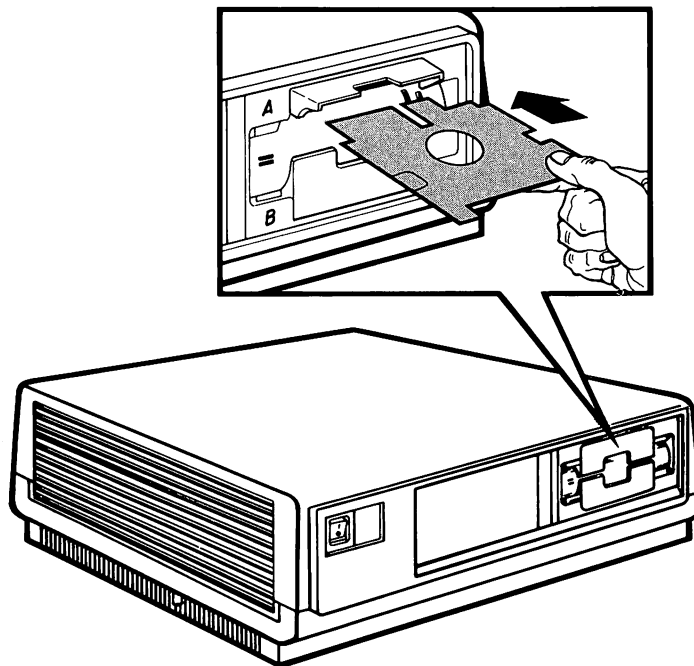

Figure 1-11. Inserting a Protective Card

The Rainbow Keyboard

Introduction

The Rainbow keyboard, shown in Figure 2-1, resembles a standard typewriter keyboard. However, the Rainbow keyboard has additional key groupings that have special functions when you use an operating system or an application program. For detailed information on how the keys work with your operating system, refer to that operating system's user's guide.

The Rainbow keys are divided into four categories.

1. Standard keys
2. Editing and cursor control keys
3. Numeric keypad keys
4. Function keys

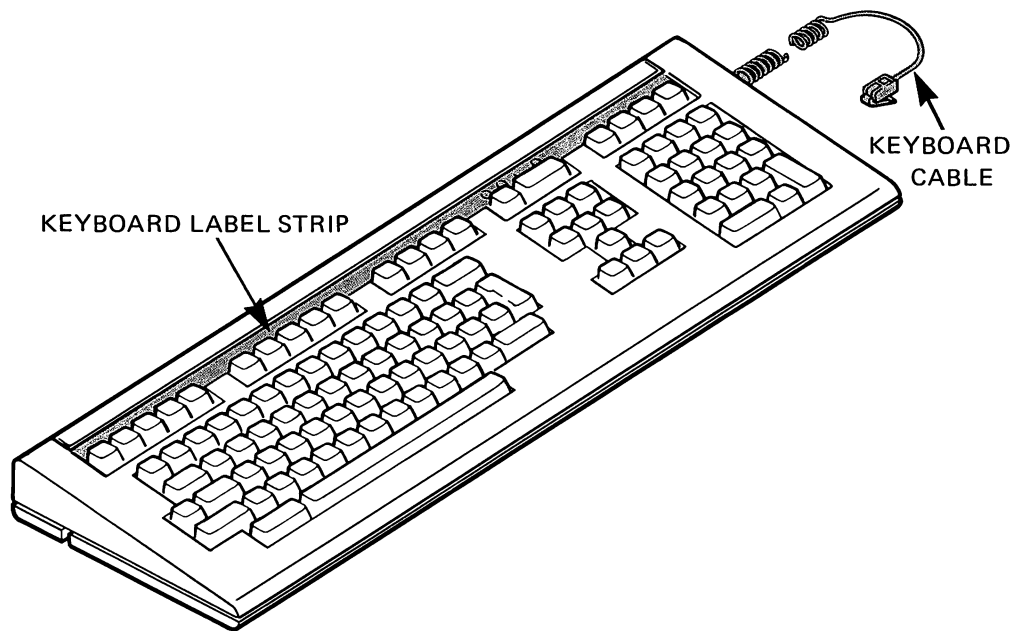

Figure 2-1. Rainbow Keyboard

Standard Keys

The standard keys, highlighted in Figure 2-2, provide the uppercase and lowercase alphabets, numbers, special characters, and punctuation. The **Shift** and **Lock** keys modify standard key characters. The **Lock** key locks the **Shift** key in position (an electronic operation, not a mechanical one). You know when the **Lock** key is in effect because the lock indicator light, located on the top row of the keyboard, is on. You may choose to have the **Lock** key affect the other standard keys as well as the alphabetic keys. See the description about lock mode in Chapter 3, *Selecting Computer Features Using Set-Up*.

Editing and Cursor Control Keys

You use the editing and cursor control keys, shown in Figure 2-3, in *Set-Up* to change screens and move the cursor to a desired position. You previously used these keys to select your keyboard language. You will also use these keys with application programs, such as editing programs and so on. Refer to your application program manual for more information on the use of these keys.

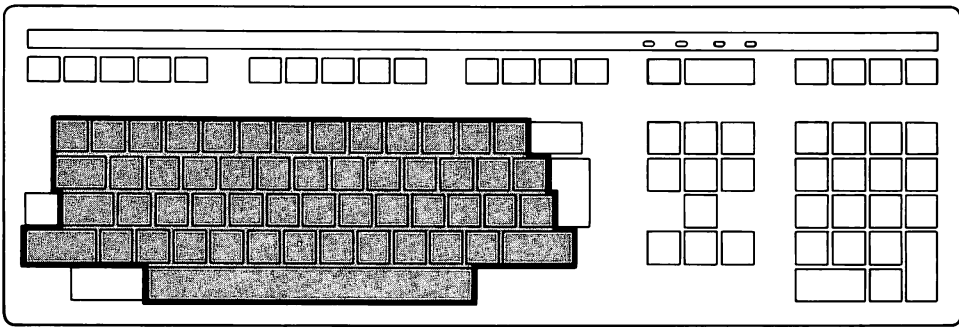

Figure 2-2. Standard Keys

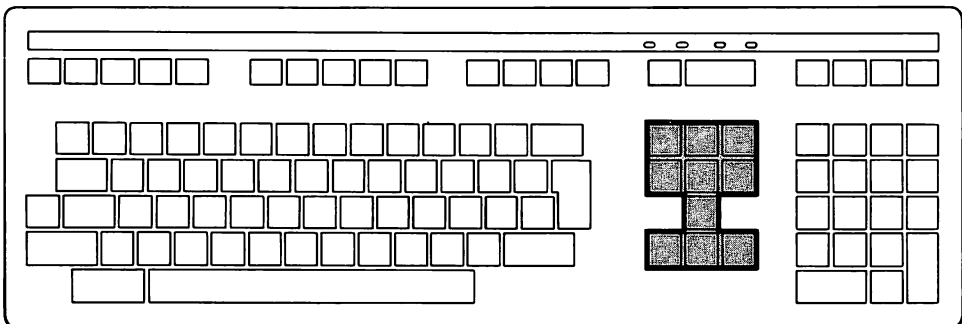

Figure 2-3. Editing and Cursor Control Keys

Numeric Keypad Keys

The numeric keys, highlighted in Figure 2-4, make certain calculator-like or number-handling application programs easier to use. You can write application programs that will redefine these numeric keys.

Function Keys

You use the function keys, highlighted in Figure 2-5, for different types of application programs such as word processing, electronic mail, or accounting spreadsheets. A label strip identifies the function keys located at the top of the keyboard.

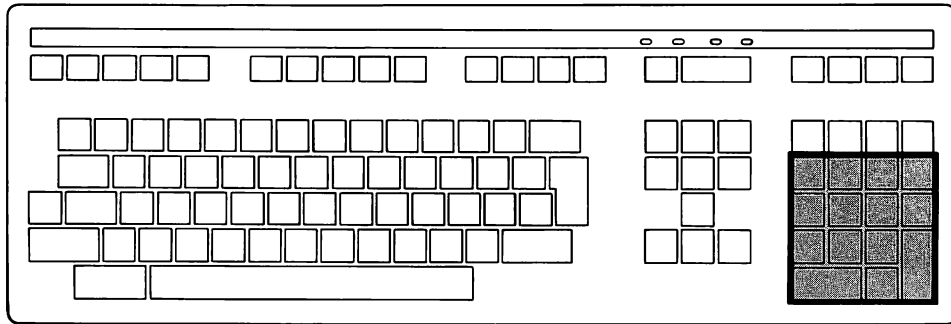

Figure 2-4. Numeric Keypad Keys

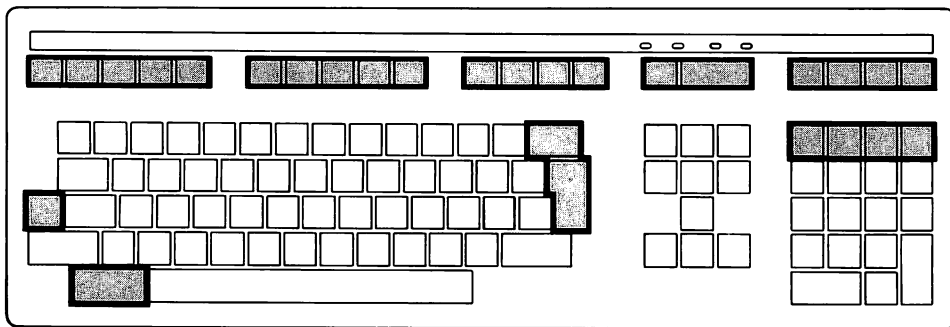

Figure 2-5. Function Keys

A description of those function keys you will use most often follows.

The **PF1** through **PF4** keys are programmable function keys that are defined by application programs.

The **⌫** key, called the delete key, erases the character you just typed.

The **Return** key performs two functions. When you use it at the end of a command, it tells the operating system to execute a command. When you use it for entering text and editing purposes, it moves the cursor to the beginning of the next line.

The **Ctrl** (control) key, always used in conjunction with certain letter keys, sends commands to an operating system or application program. To use the **Ctrl** key, you press and hold it down while simultaneously pressing the required letter key.

The **Hold Screen** key allows you to freeze a display that is currently on the screen. Pressing the **Hold Screen** key stops the type from scrolling off the screen so you can look at it. You press the **Hold Screen** key again to resume scrolling. This also means that the characters you type are not displayed until you press the **Hold Screen** key again.

The **Print Screen** key causes the printer to print only the text currently on the screen. You use this key to print short messages when the Rainbow is set up as a terminal.

The **Set-Up** key allows you to control various computer features such as printer and communications settings, margin bell volume, cursor style, screen background, identification messages, auto-repeat, auto-boot, and many more. See Chapter 3, *Selecting Computer Features Using Set-Up*, for details.

The **Break** key disconnects a modem link to a remote computer. In application programs, you can use the **Break** key the way the application program has designed it to be used.

The **BS** (back space) key moves the cursor back one character and erases it.

The **LF** (line feed) key tells the operating system that you have finished typing a command and want the command executed (as the **Return** key does). The **LF** key also indexes to the next line.

The **Compose Character** key initiates compose sequences.

The remaining special function keys are intended to be used with application programs and are not used at the command level of the operating system.

Compose Character Sequences

Compose character sequences allow you to create and display accented characters, ligatures, numerical fractions, and other special characters that may not be on your keyboard. There are two forms of compose sequences that you can use to create and display a character.

- Two-key compose sequence
- Three-key compose sequence

Two-Key Compose Sequence

A two-key compose sequence uses two keys to create a different character. For example, on the British keyboard, typing the acute accent key, then typing E results in a new character: an E with an acute accent.

Note that you do not use the **Compose Character** key to create two-key compose sequences. The only keys for which you can use the two-key compose sequence are:

- Diaeresis/umlaut mark ••
- Acute accent ´
- Grave accent `
- Circumflex ^
- Tilde ~

You must type the character key before the letter key in two-key compose sequences.

NOTE

The two-key compose sequence cannot be used on the North American (English) keyboard.

Three-Key Compose Sequence

You can use the three-key compose sequence on any keyboard. To start a compose sequence, you press the **Compose Character** key; then, you press the

next two characters of the compose sequence. (See Figure E-1 in Appendix E for the compose sequences and resulting characters.) For example, if you press the **Compose Character** key, the acute accent key, and the letter **E** in sequence, the screen displays an E with an acute accent.

The order in which you type the characters is important. Certain sequences have an obvious order – the AE ligature and the 1/4 fraction, for example. In these examples, the order may not be reversed. When you compose the E with an acute accent, you may type either the **E** or the acute accent after you press the **Compose Character** key.

Use the  key if you want to cancel a compose sequence.

Keyboard Indicator Lights

The keyboard has four lights that indicate when you are using a specific function. See Figure 2-6.

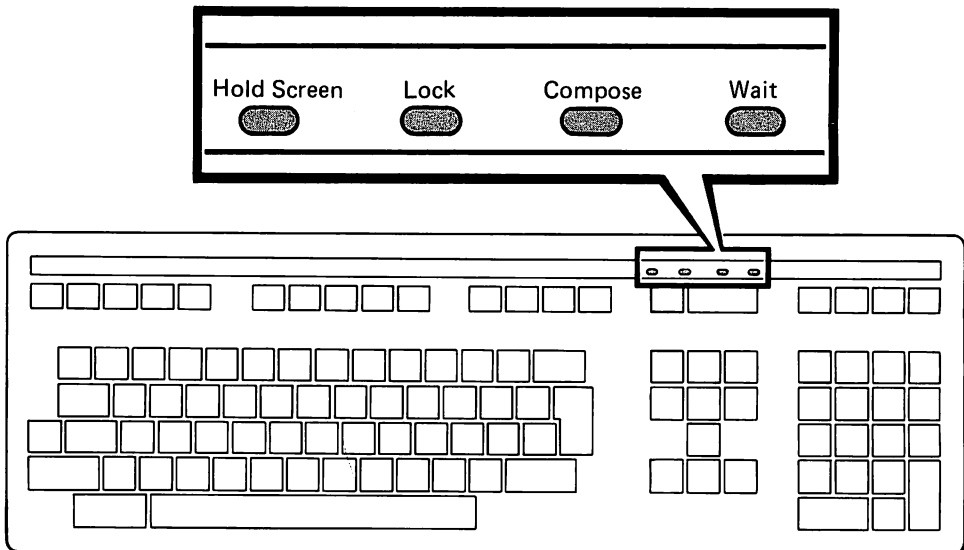

Figure 2-6. Keyboard Indicator Lights

These lights can also indicate error conditions; in which case all four lights flash. The lights have the following meanings when they are on.

Light	Meaning
Hold Screen	You pressed the Hold Screen key. You cannot add new data to the monitor's screen until you press Hold Screen again.
Lock	You pressed the Lock key, enabling uppercase lock mode.
Compose	You pressed the Compose Character key and are in a compose sequence.
Wait	Keyboard transmission has been temporarily stopped by the computer. If this light is on, any additional characters you type are lost, and the keyboard beeps once for each key you press.

Character Coding

Digital has extended standard ASCII coding to introduce the DEC Multinational Character set. This set gives a uniform coding for all characters used in most European languages. It also adds characters such as ϕ , ©, $\frac{1}{4}$, and $\frac{1}{2}$. The full set is shown in Appendix F. To represent these extra characters, Digital uses 8 bits (standard ASCII uses 7 bits). Digital's Multinational Character set is an extension of, and fully compatible with, the ASCII codes generally used in North America.

European countries (and French Canada) also define modifications to ASCII codes that replace certain ASCII characters with some of the extra characters in use in their language. These codes are known as National Replacement Character (NRC) codes. They use 7 bits to code each character. These code sets can differ from the ASCII codes in up to twelve positions. They are listed in Appendix F.

The Rainbow computer allows you to choose either Digital's 8-bit Multinational Character set, or the 7-bit National Replacement Character set associated with your keyboard. See Chapter 3, *Selecting Computer Features Using Set-Up*, for details.

Changing the Keyboard/Language

When you first turned on your Rainbow computer, you made a keyboard selection. To change this selection to match another keyboard, first, change the Set-Up setting for the keyboard to 0 (not selected) as explained in Chapter 3, *Selecting Computer Features Using Set-Up*. Then, to save the selection value type: **Shift/S**. To reset the computer, type: **Ctrl/Set-Up**.

You will see the Keyboard Selection Menu on the screen. Follow the instructions on the screen to select a keyboard.

Your Rainbow computer will support all 15 country and language variant keyboards manufactured by Digital. On the keyboards shown in the top portion of the menu (Figure 2-7), the language in which the Main System Menu, diagnostic messages, Set-Up, and tests appear will match the keyboard (e.g., French for the French, Swiss French, and French Canadian keyboards). On keyboards shown in the lower portion, this text will be in English. You can purchase different variations of the computer to cover all the different language variations.

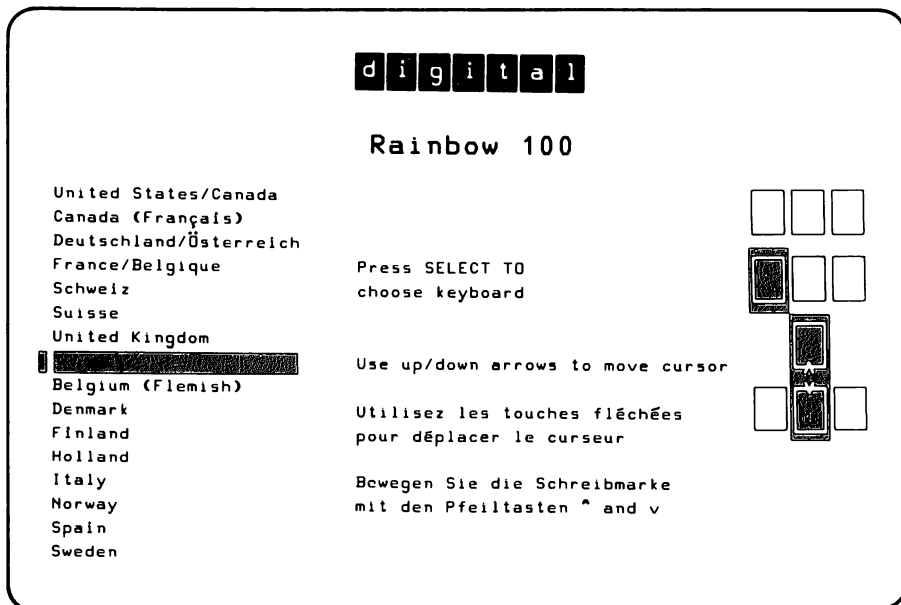

Figure 2-7. Keyboard Selection Menu

3

Selecting Computer Features Using Set-Up

Introduction

Set-Up allows you to control various features of the Rainbow computer. Some of the features that you can set include the following.

- Tab stops
- Transmit and receive speeds to match those of your printer
- Transmit and receive speeds to match those of any communications device attached to the computer
- Number of characters displayed across the monitor (screen width)
- Cursor style (block or underline)
- Screen background (dark or light)
- Automatic repeating of keyboard keys
- Margin bell and bell volume
- Keyclick feature and its volume
- Answerback message for identification on a communications line
- Auto-booting from the diskette drive of your choice
- Keyboard language selection

Entering Set-Up to Change Features

When you press the **Set-Up** key, highlighted in Figure 3-1, the computer enters Set-Up mode and displays the first Set-Up screen, shown in Figure 3-2 and Figure 3-3. In Set-Up, the Set-Up display temporarily replaces the text on your screen; however, it does not erase any of your text. You press the **Set-Up** key to exit from Set-Up and to make the Rainbow computer display your original text again. If you enter Set-Up while text is scrolling, the text stops scrolling until you exit Set-Up.

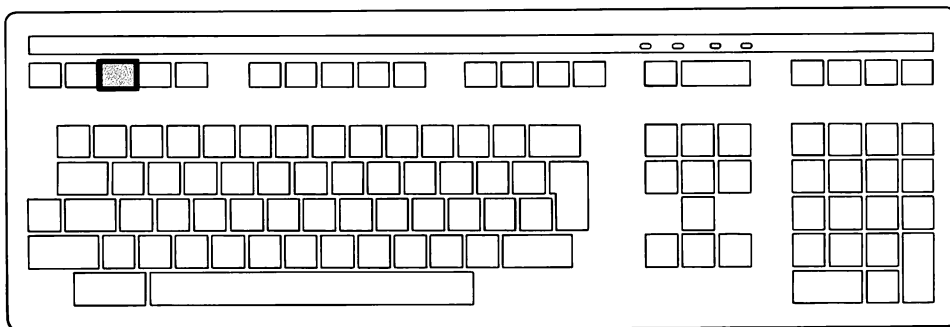

Figure 3-1. Set-Up Key Location

Set-Up features are divided into areas of common use called major headings. There are six major headings in the Rainbow computer, each having a different display. Each major heading has a number of selections, called minor headings, that you can change. The major headings and the number of selections in each are as follows.

Major Heading	Number of Selections (Minor Headings)
Tabs	2
Parameter Settings	27
Modem	5
Printer	2
Miscellaneous	3
Auto-Boot	6

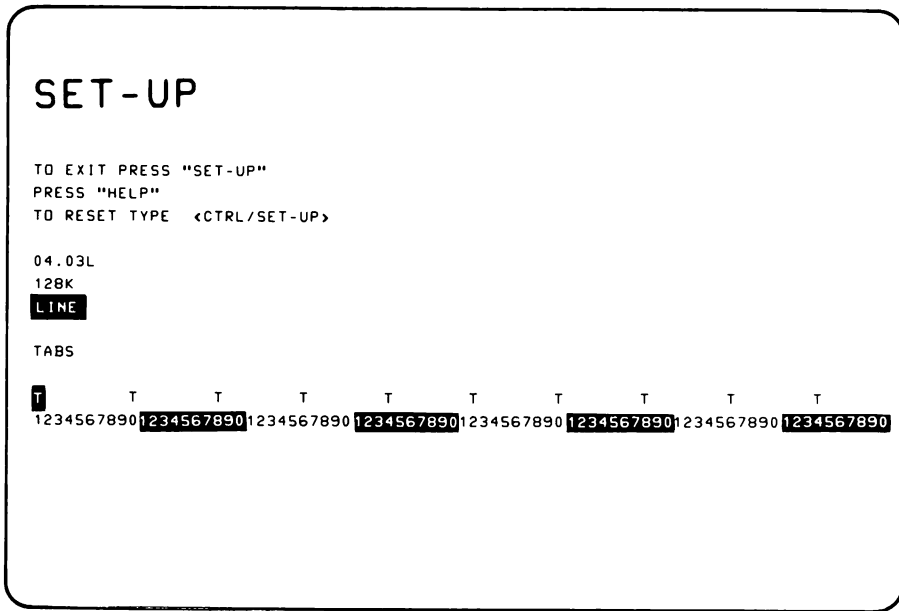

Figure 3-2. First Set-Up Display

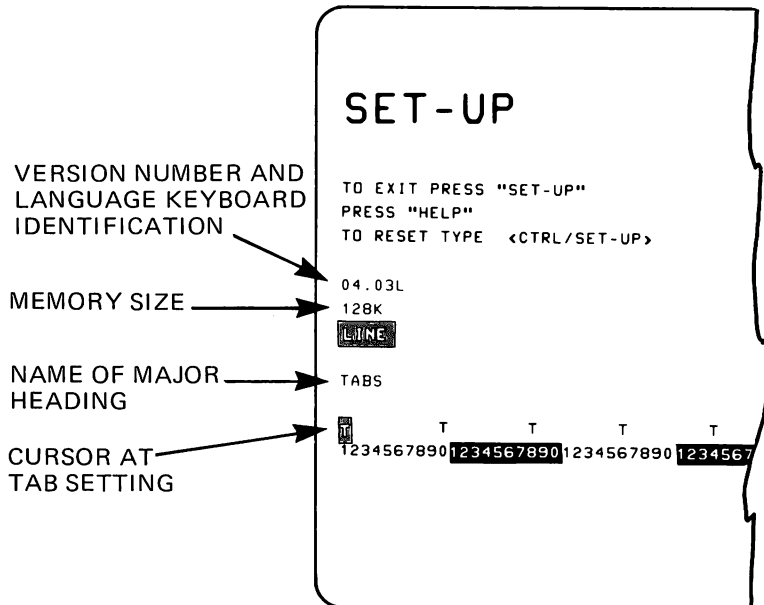

Figure 3-3. Set-Up Screen Components

Selecting Computer Features Using Set-Up

After you press the **Set-Up** key, you use the **Next Screen** or **Prev Screen** key to move from one major heading to another. Once you select a major heading, you use the → or ← key to move through its minor headings, parameters, or tab settings.

The minor heading you select is displayed in reverse video; a tab setting is displayed as a T character in a cursor position. You use the ↑ or ↓ key to move through the values of each minor heading. Table 3-1 outlines the keys you must use to move through Set-Up.

Table 3-1. Keys Used to Move Through Set-Up

Key Used	Result
Next Screen or Prev Screen	Moves from one major heading to another
→ or ←	Moves from one minor heading to another within a major heading
↑ or ↓	Selects a minor heading

Help

While in Set-Up, if you press the **Help** key, a help message displays on the screen. This help message is a quick reminder of how to change the settings in Set-Up. Pressing the **Help** key again returns you to your current major heading. You cannot make any changes until you exit Help.

Default Set-Up Values

When your computer was delivered from the factory, its Set-Up features were set to specific values called default values. Sometimes, you may need to change these values as described in the following sections. If you do change some values and then would like to recall these default values, type: **Shift/D**. The default values are not automatically saved, they are just loaded into the temporary operating memory.

NOTE

Recalling the default Set-Up values also recalls the default communications baud rates, data bits, and parity for both the COMM connector and the PRINTER connector.

CAUTION

Recalling the default Set-Up values erases any text that was on the screen before you entered Set-Up.

Tabs Major Heading

When you enter Set-Up, you are in the Tabs major heading, shown in Figure 3-4.

While viewing the Tabs Set-Up screen, you can:

1. Switch the computer between line and local mode operations
2. Change tab stop settings
3. Move to the next major setting by pressing the **Next Screen** key
4. Return to a previous major heading by pressing the **Prev Screen** key.

NOTE

The number 04.03L shown in the Set-Up screens is the version number and language keyboard identification of the computer. Your version number and keyboard identification may be different.

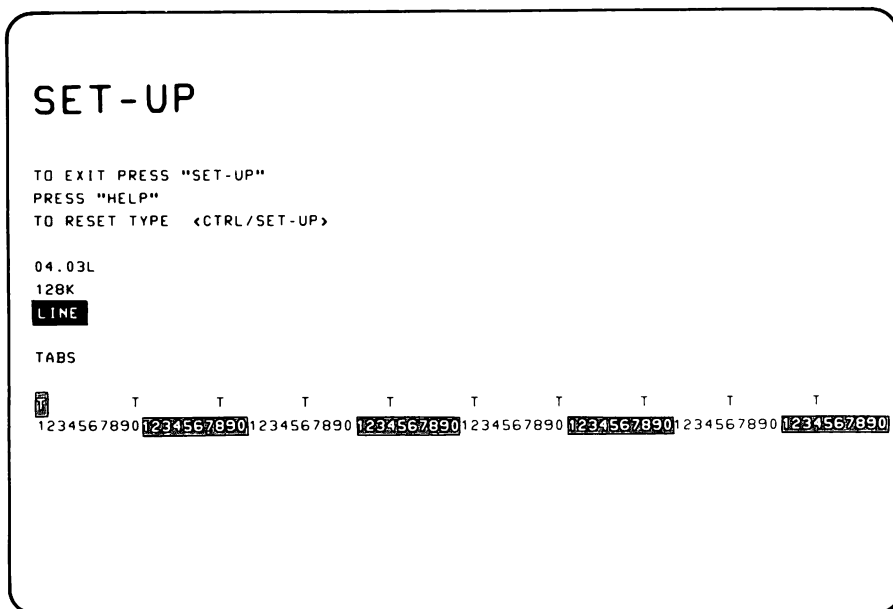

Figure 3-4. Set-Up Display – Tabs

Local and Line

The local and line mode feature applies to using your Rainbow computer as a terminal. If you select line mode, your computer can communicate with other devices, such as a remote computer.

If you select local mode and then exit Set-Up, the characters of the keys you press on the keyboard will be displayed on the screen but will not be transmitted to the remote computer. Similarly, characters transmitted from the remote computer will not be displayed on the screen while the computer is in local mode.

While in Set-Up, you can change this feature by typing **L**.

Tab Stops

The numbers across the middle of the Tabs Set-Up display represent columns on the screen in which you can type characters. There are either 80 or 132 possible character positions, depending on the screen-width setting. The Ts indicate the current tab stop settings. To change the tab settings, follow the instructions in Table 3-2.

CAUTION

If you switch between 80 and 132 columns while creating or editing a document, your original screen contents will be lost.

Table 3-2. How to Change Tab Stops

Purpose	Action
To clear all tab stops	Press Ctrl/Tab
To move the cursor to a new setting	Press space bar , ← , → , Return , or Tab
To set or clear the new tab stops*	Press T or the ↑ and ↓ keys
To save the new tab stops	Press Shift/S
To use the original factory (default) tab stops	Press Shift/Tab

*To set more than one tab stop, repeat the second and third steps.

Parameter Settings Major Heading

From the Tabs major heading, you press the **Next Screen** key to get to the Parameter Settings (Param Set) major heading. On the Parameter Settings display, shown in Figure 3-5, you will see the following.

- The current values (0s and 1s) of all the minor heading features within Parameter Settings

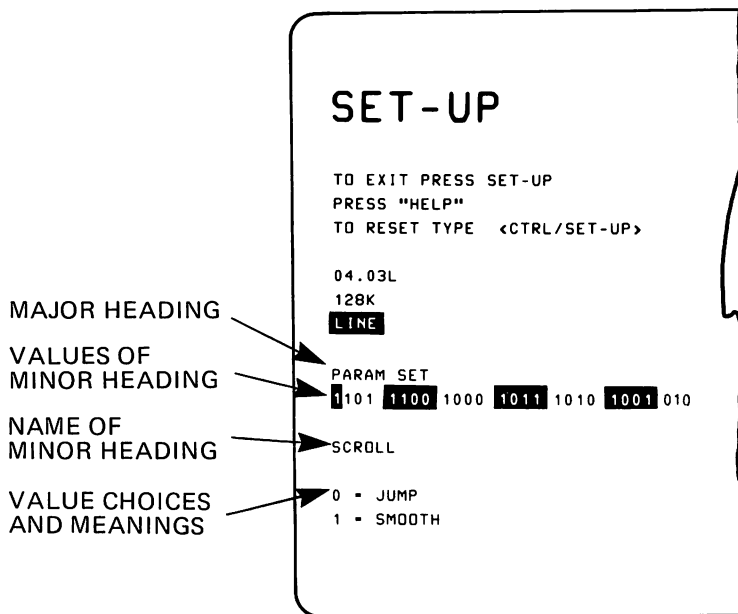

Figure 3-5. Set-Up Display – Parameter Settings

- The name of the currently referenced minor heading feature
- The value choices and meanings of the parameters

Figure 3-6 summarizes the selections possible and shows their default values.

To change the value of a minor heading, you press the ↑ or ↓ key. To proceed to the next minor heading, you press the → key. To return to a previous minor heading, you press the ← key. To return to the first minor heading, you press the **Return** key.

Various operating systems need certain selections set to specific values. Refer to the user's guide for that operating system.

The following paragraphs describe the parameter settings.

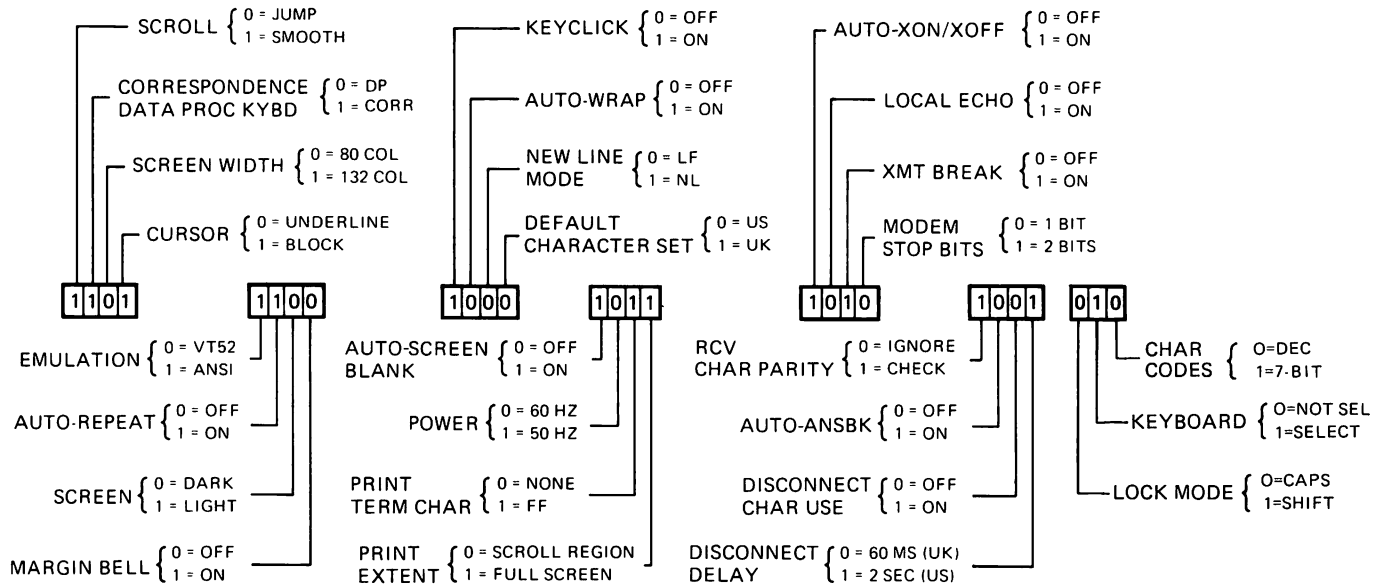

Figure 3-6. Summary of Parameter Settings

Scroll

Scroll applies to the upward and downward movement of lines of text on the screen to make room for new lines. You can choose either jump or smooth scroll.

With jump scroll, the characters on the screen advance upward a full line of characters at a time, and new lines of characters are added at the bottom of the screen. With smooth scroll, the lines of text on the screen advance one-tenth of a line (one scan line) at a time. Smooth scrolling increases your ability to read new data as you receive it. You can set a limit on the smooth scroll rate in the Misc(ellaneous) major heading. A scroll rate setting of 1, 2, or 3 represents 3, 6, or 12 lines per second, respectively.

The default is smooth scroll. If you want to change the default, press the ↑ key to change the 1 to a 0 (from smooth scroll to jump scroll).

Correspondence/Data Processing Keyboard

Most keys on the Rainbow keyboard have either one or two characters labeled on them. When you press the **Shift** key, the upper character is displayed on the screen. Some keys on keyboards used in countries other than the United States and Australia have keys with three or four characters labeled on them. On these keyboards, you can choose which characters you want to display on the screen as follows. The default is correspondence.

Set-Up Selection

Keyboard Characters Used

Correspondence

Characters labeled on the left side of the key cap

Data Processing

Characters labeled on the right side of the key cap

Screen Width

This parameter allows you to select the monitor's screen width, either 80 or 132 columns. The number of characters that the computer can display in each screen width are as follows. The default is 80 columns.

Screen Width	Single-Width Characters	Double-Width Characters
80	80	40
132	132	66

CAUTION

Changing the screen width erases the data displayed on the screen before you entered Set-Up. You should not change the screen width setting while creating or editing a file.

Cursor

This parameter setting allows you to choose between two cursor displays: a blinking underline () or a blinking block (). The default setting is the blinking block cursor.

Emulation

The emulation selection allows you to choose the style of character strings for special control functions. If you choose VT52, the Rainbow computer transmits and responds to character strings like a VT52 video terminal. If you choose ANSI, the computer transmits and responds to character strings according to the format established by the American National Standards Institute (ANSI). The default is ANSI.

Auto-Repeat

When enabled, the auto-repeat feature allows you to repeat a character automatically when you hold down its key for more than one-half second. You can choose to have this feature on or off. All keys auto-repeat except the **Shift**, **Lock**, **Ctrl**, and **Compose Character** keys. Keys within a compose sequence and keys **F1** through **F5** also do not auto-repeat. The default setting is on.

Screen

The screen setting allows you to choose a dark or light background. The dark setting shows light characters on a dark background. The light setting shows dark characters on a light background. The default is dark.

Margin Bell

The margin bell setting allows you the choice of hearing a bell when the cursor moves past the eighth character position from the end of the line or no bell at all. You can adjust the bell volume under the Miscellaneous major heading. The default is off.

Keyclick

The keyclick setting allows you the choice of hearing a clicking sound when you press a key fully or no sound at all. You can adjust the keyclick volume under the Miscellaneous major heading. The default is on.

Auto-Wrap

With auto-wrap set to on (1), the computer automatically places any displayable character received, when the cursor is at the right margin, at the beginning of the next line. Text will scroll up if needed. With auto-wrap set to off (0), any character trying to print past the right margin writes over the last character position on that line. In terminal mode, this feature should be set to match the remote computer. The default is off.

New Line Mode

In line feed (LF) mode, a received line feed performs a cursor index to the same character position on the next line. Pressing the **Return** key sends the carriage return code only. In new line (NL) mode, a received line feed will cause the cursor to move to the beginning of the next line. Pressing the **Return** key causes the transmission of both a carriage return and a line feed code. The default is line feed (LF).

Default Character Set

The default character set parameter allows you to set your computer to USASCII (0) or UK (1). If you choose USASCII, the computer transmits codes that agree with the American Standard Code for Information Interchange (ASCII). These codes are standard for printers and communications devices so they can transfer information using common codes to represent characters. When you set this parameter to UK (1), the code for the # symbol, on reception only, causes display of the British pound sign (£). The default is USASCII.

Auto-Screen Blank

This setting allows you to enable auto-screen blank. If you set this feature to on (the default condition), the computer turns the text on the screen off after about 30 minutes of not receiving characters. The computer displays a blinking phantom cursor, shown in Figure 3-7, on the screen to indicate that it is still on. To redisplay the data you had on the screen, you press the **Shift** key. The **Shift** key has no meaning to a program. (This is important because the program may have been waiting for a response from you before the screen went blank.)

Power

The power setting allows you to match the monitor's screen refresh rate with the power line frequency. In North America, 60 Hz is common; 50 Hz is common in other countries. A setting that does not match the local line frequency can cause a screen that flickers. The default is 60 Hz.

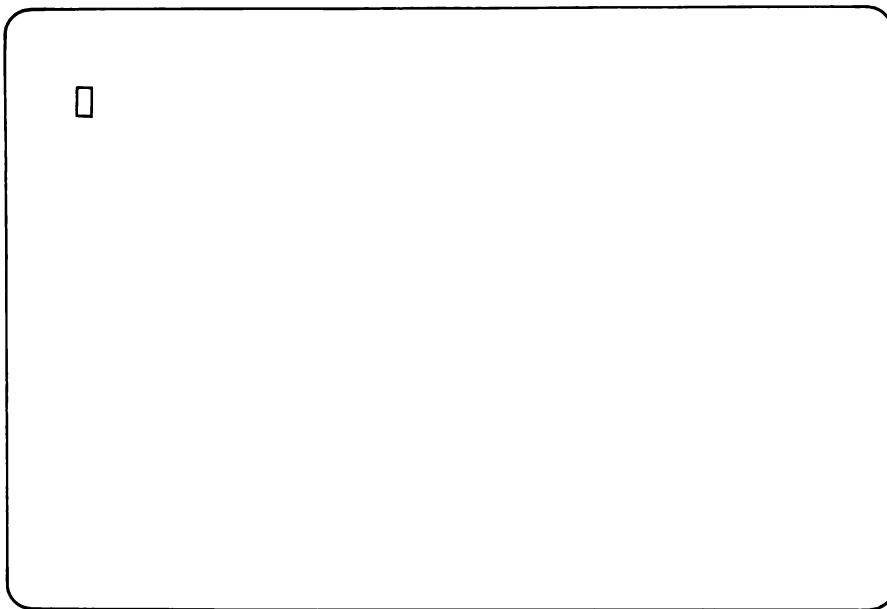

Figure 3-7. Auto-Screen Blank Phantom Cursor

Local Echo

This setting allows you to set local echo to on (except in Set-Up) so that all keys you type display on the screen and transmit to the remote computer. You should enable this feature if the remote computer is not displaying the characters you type. When you set this feature to off, the computer transmits all keys you type to the remote computer but does not display them on the screen.

When not in terminal mode, the operating system of the Rainbow computer displays the characters you type on the screen. The default is off.

Transmit Break

When you enable transmit break and press the **Break** key, the system places a space signal on the transmit data line. If the terminal is not transmitting, the system will not send any signal. Also, the system will not send a space signal when you press the **Break** key if this selection is disabled. The default is enable.

NOTE

Disabling the transmit break function does not affect a **Shift/Break**, which causes the modem line to disconnect, or a **Ctrl/Break**, which sends the answer-back message on the transmit data line.

Modem Stop Bits

The modem stop bits selection allows you to place one or two stop bits at the end of each character's data pattern. Normally, you use one stop bit with baud rates higher than 110, and two stop bits with baud rates of 110 and lower. The default is one bit.

Print Termination Character

You should enable the print termination character setting only if you want to use your computer as a terminal. This selection allows you to determine if a form feed (FF) character is to be sent automatically to the printer at the end of every print screen function. The default is form feed.

Print Extent

This selection applies only to terminal mode. It allows you to determine the characters that will be printed during a print screen operation. When you set the feature to full screen, all characters on the screen print. When you set the feature to scroll region, only the characters in the scroll region print. The scroll region is the screen area between the top and bottom margins. Normally, the remote computer selects the margins; if it does not, all characters on the screen are printed. The default is full screen.

Auto-XON/XOFF

This setting allows you to enable auto-XON/XOFF. If you set auto-XON/XOFF to on, the Rainbow computer will automatically be synchronized to a remote computer that uses XON and XOFF control signals. When the Rainbow computer receives more characters than it can handle, it automatically sends an XOFF control character to the remote computer, which tells it to stop sending data.

When the Rainbow computer can accept more data, it sends an XON control character to tell the remote computer to resume data transmission. Also, on reception of an XOFF signal, the Rainbow computer stops sending data to the remote computer. On receipt of an XON signal, the Rainbow computer resumes sending data. The default is on.

Received Character Parity

The received character parity setting allows you to have the computer check for errors in the data patterns of received characters. For example, if the remote computer sends an even number of data pulses for even parity, but the Rainbow computer does not receive an even number of pulses, the computer does not display the character; instead, it displays the substitution character ☐.

When you set this selection to ignore, the Rainbow computer does not check for parity errors in received characters. The default is check.

Auto-Answerback

The auto-answerback feature applies only to terminal mode. If you choose to enable this setting, the Rainbow computer automatically transmits its answerback message when a telephone connection is made. (See “Answerback Message” on page 42.) When you set this feature to disable, no message is sent. The default is disable.

Disconnect Character Use

The disconnect character use selection applies only to terminal mode. If you choose to enable this setting and the Rainbow computer receives a disconnect character, it will disconnect the telephone line. (See Chapter 4, Connecting a Printer to Your Rainbow Computer, for additional information.) Typing **Shift/Break** sends a disconnect character on the transmit data line. The default is disable.

Disconnect Delay

The disconnect delay selection applies only to terminal mode. It allows you to select either a 60 ms delay (typical in the United Kingdom) or a 2 second delay (typical in the United States and other countries) after disconnecting the telephone line before accepting any incoming call. The default is 2 seconds.

NOTE

Disconnect delay is active only for FDXB and FDXC modem protocols. This selection is ignored by FDXA modem protocol.

Lock Mode

The lock mode setting allows you to choose how you want the **Lock** key to be used. If you select caps lock, the alphabetic keys you type will generate their shifted characters and the numeric keys will remain unchanged. If you select shift lock, all the keys you type will generate their shifted characters. The default is caps.

Many foreign keyboards generate a different set of characters depending on how lock is set. Table 3-3 shows an example of how lock mode affects the Swiss (German) keyboard.

Table 3-3. Lock Mode on the Swiss (German) Keyboard

Selection	Lock Key	Shift Key	Character Generated
Caps Lock	Off	Off	ä
	On	On	À
Shift Lock	On	Off	À
	On	On	Ä

Keyboard

The keyboard selection allows you to choose another keyboard language. When set to not selected, you can choose a different language from the Keyboard Selection Menu. Once you choose your language, the setting automatically returns to selected. Selecting a keyboard is explained in Chapter 2, The Rainbow Keyboard. The default is not selected.

Character Codes

This setting allows you to select the DEC Multinational Character set or the National Replacement Character (NRC) set. In terminal mode, when you set this feature to 0, the system uses the DEC Multinational Character set (see Appendix F). This set has 256 characters and uses 8 bits to code each character. When you set this feature to 1, the system uses the National Replacement Character set that corresponds to your keyboard (see Appendix F). This set has 128 characters and uses 7 bits (default) to code each character.

If you use the **Compose Character** key to compose a character not in your National Replacement Character set, the keyboard bell rings and no character displays.

Answerback Message

This feature allows you to store an answerback message in the computer while you are in any of the major headings. (The computer remembers your current major heading.) You start by typing $\overline{\text{Shift/A}}$. The computer responds by displaying AUTO-ANSBK and A = on the screen, as shown in Figure 3-8. Next, you type a delimiter, which may be any character, followed by your message of up to 20 characters. (The delimiter is not sent as part of the message.) The default is disable.

Example:

```
A = \HELLO G PLEASE LOGIN\  
      ↑           ↑           ↑  
  delimiter   control code  delimiter
```

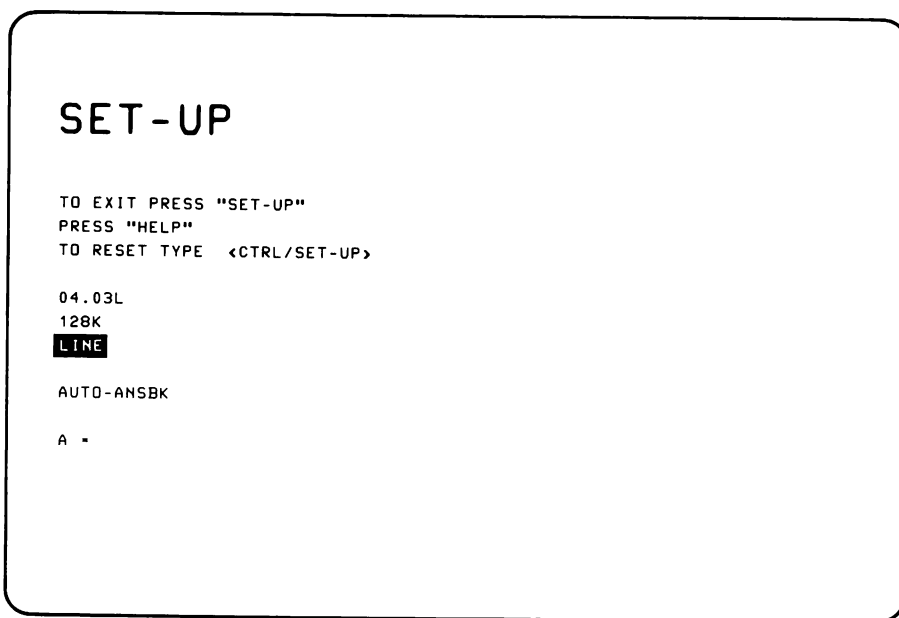

Figure 3-8. Set-Up Display – Auto-Answerback

NOTE

You may use control characters, such as the **Return** key, in an answerback message. A control character is echoed on the screen as a reverse-video-associated ASCII character. For example, a bell is a reverse-video G for **Ctrl/G**; a **Return** is reverse-video M.

The answerback message automatically ends after you enter the 20th character. You can end the message before the 20th character by typing the same delimiter you started with. This will also return you to your current major heading.

You can correct an error in your message only by exiting answerback, reentering, and retyping the message. Beginning a message with two identical characters erases the message. To save the answerback message along with the other parameters, you type **Shift/S**.

You cannot display the saved answerback message once it is stored in memory. Your Rainbow computer transmits the answerback message to the remote computer when it receives an ENQ control code from the remote computer or an application. While in terminal mode, you can transmit the message by typing

Ctrl/Break .

Modem Major Heading

The Modem major heading, Figure 3-9, allows you to set the features of the communications (COMM) connector that is on the back of the system unit. This connector allows you to attach a communications cable to a telephone modem or to a remote computer. You get to the Modem major heading from the Parameter Settings major heading by pressing the **Next Screen** key.

Remember, you can change a minor heading by pressing the → or ← key, and change the value of a minor heading by pressing the ↑ or ↓ key.

Changing Modem Data Bits and Parity (DATA B/P)

This minor heading determines two separate but related communications features – data bits and parity. Information travels on the communications line according to a data pattern. The pattern begins with a start bit. The DEC Multinational Character set uses 8 bits; the National Replacement Character set uses 7 bits. This selection determines if the computer is to use 7 or 8 data bits for each character and the type of parity to be used, as listed in Table 3-4. You press the ↑ or ↓ key to change the value to the selection you need.

Setting the Transmit Baud Rate (XMT BAUD)

This minor heading determines the baud rate, the speed at which characters are transmitted by the Rainbow computer. This setting must match the receive speed of the remote computer. You press the ↑ or ↓ key to cycle through the following transmit baud rates.

50, 75, 110, 134.5, 150, 200, 300, 600, 1200,
1800, 2000, 2400, 3600, 4800, 9600, 19200

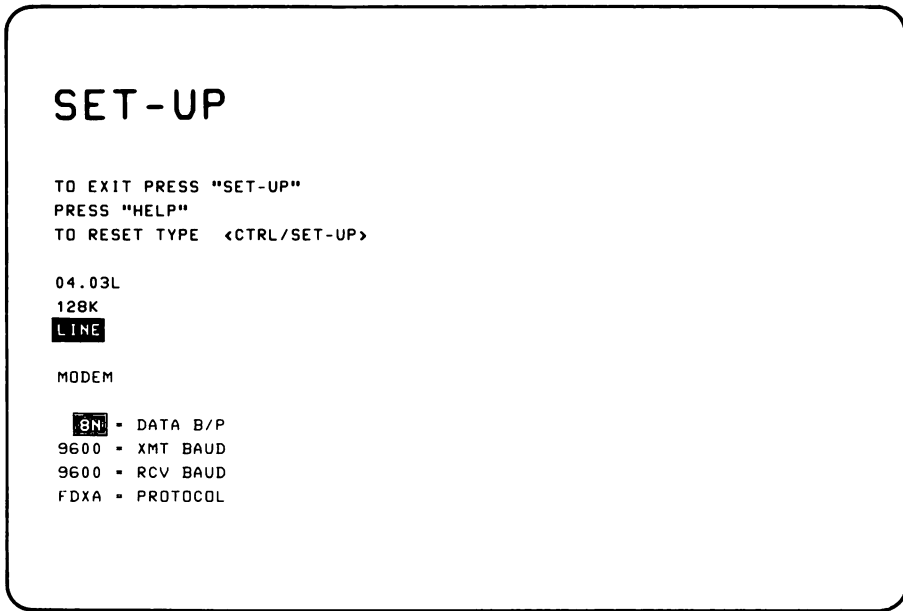

Figure 3-9. Set-Up Display – Modem

Table 3-4. Modem and Printer Data Bits and Parity Selection

Characters Displayed	Data Bits per Character	Type of Parity upon Transmission
7O	7	Odd
7E	7	Even
7N	7	No parity
7M	7	Mark
7S	7	Space
8O	8	Odd
8E	8	Even
8N	8	No parity

Setting the Receive Baud Rate (RCV BAUD)

This minor heading determines the receive baud rate, the speed of the characters coming from the communications line as expected by the Rainbow computer. This speed must be set to match the transmit speed of the remote computer. You press the ↑ or ↓ key to cycle through the available receive baud rates, which are the same as the choices listed for the transmit baud rate. You can set a receive baud rate different from the transmit baud rate as long as the remote computer is set to match these different rates.

Setting Protocol

The rules for communications, the signals used, and how the signals are interpreted all form the communications protocol. The protocol minor heading determines the method used to disconnect a telephone line. You press the ↑ or ↓ key to cycle through the available modem protocols, listed in Table 3-5. The modem protocols are explained in more detail in Chapter 5, Communicating with Another Computer.

Table 3-5. Modem Protocols

Characters Displayed	Modem Protocol Selected
FDXA	Full-duplex, no modem (data leads only) with or without auto-XON/XOFF control
FDXB	Full-duplex, full modem control with or without auto-XON/XOFF control
FDXC	Asymmetrical full-duplex with modem control (requires a special cable)

Printer Major Heading

The Printer major heading, Figure 3-10, allows you to set the communications settings for the PRINTER connector that is on the back of the system unit. This connector allows you to connect a printer, such as Digital's LA50 Personal Printer, LA100 Letterprinter 100, or LQP02 Letter-Quality Printer, to your Rainbow computer. You must set the communications settings of the printer connector to match the settings on your printer.

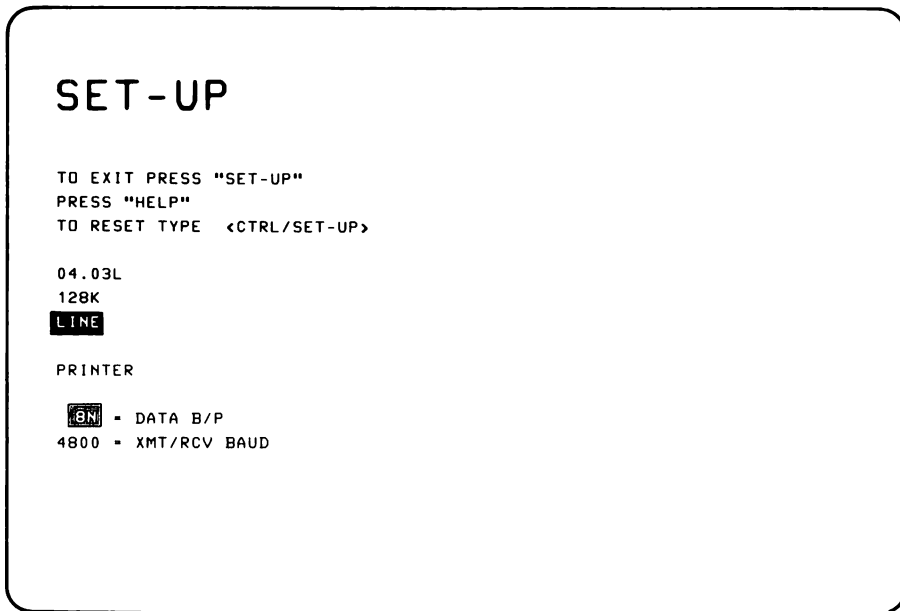

Figure 3-10. Set-Up Display – Printer

Setting Printer Data Bits and Parity

This minor heading selects the data bits per character for the printer and the parity of the data pattern. You press the ↑ or ↓ key to cycle through the available selections, listed in Table 3-4. Stop when the computer displays the selection you need. Your selection must match the settings on your printer.

Setting Printer Transmit/Receive Baud Rate

Once you select the transmit/receive baud rate minor heading, you press the ↑ or ↓ key to cycle through the following baud rates. Stop when the displayed baud rate matches the baud rate set on your printer.

75, 150, 300, 600, 1200, 2400, 4800, 9600

Table 3-6 lists the range of baud rates for the printers.

Table 3-6. Baud Rates for Digital's Personal Printers

Printer	Factory Set Baud Rate	Available Range
LA50 Personal Printer	4800	110 to 4800
LA100 Letterprinter 100	4800	50 to 9600
LQP02 Letter-Quality Printer	4800	110 to 9600

Miscellaneous Major Heading

You press the **Next Screen** key to get to the Miscellaneous (Misc) major heading, Figure 3-11, from the Printer major heading. You use this heading to select the scroll rate for smooth scrolling, the keyboard bell volume, and the keyclick volume. You may set each of these as you prefer.

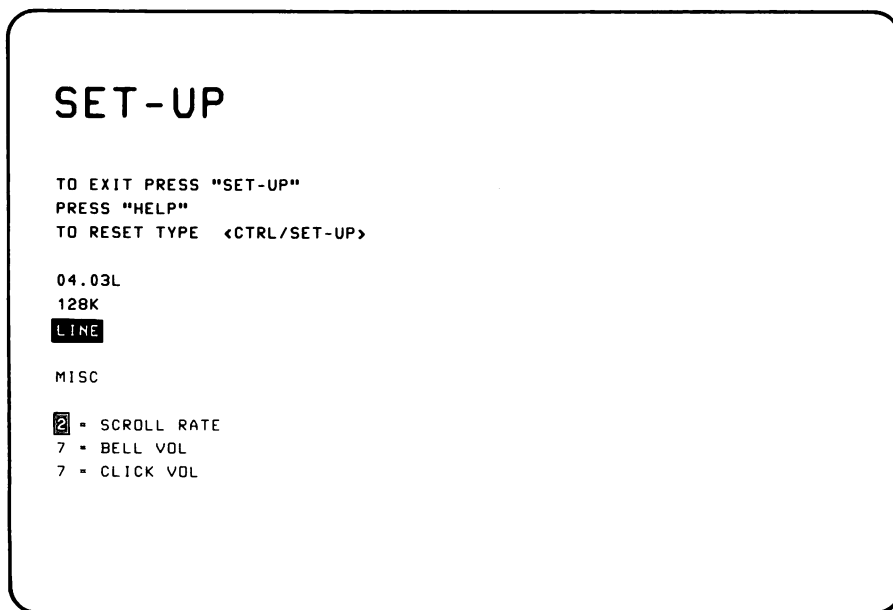

Figure 3-11. Set-Up Display – Miscellaneous

Scroll

The Rainbow smooth scroll speeds are 3.6 or 12 lines per second (lps). Set the digit to 1 for 3 lps; to 2 for 6 lps; or to 3 for 12 lps. There are no selections for jump scroll.

Bell Volume

The bell volume adjusts the bell tone for the margin bell and the bell that sounds when you turn on the Rainbow computer. You choose a number, 1 through 8 (8 being the loudest), to indicate the bell volume. After each new volume selection, the bell sounds to indicate the volume adjustment level.

Keyclick Volume

You adjust keyclick volume by setting the digit to 1 through 8 (8 being the loudest). After you select the volume, press the keys on the keyboard to check the new volume level.

Auto-Boot Major Heading

You press the **Next Screen** key to access the Auto-Boot major heading (Figure 3-12) from the Miscellaneous major heading. This Set-Up feature allows you to choose a specific diskette drive to automatically start from when you turn on or reset your Rainbow computer. If you do not select a diskette drive, you will see the Main System Menu when you turn on the Rainbow computer. Use the **↑** or **↓** key to select the available diskette drive for your auto-boot devices. This can be a diskette drive (A, B, C, D) or a hard (Winchester) disk drive (W).

Type **Shift/S** to save the selection.

Insert an operating system diskette in the selected drive.

Press **Set-Up** and **Ctrl/Set-Up** to reset the computer.

If you select a drive from which to automatically start, but forget to put an operating system diskette in that drive, you will see the Main System Menu and a drive not ready message.

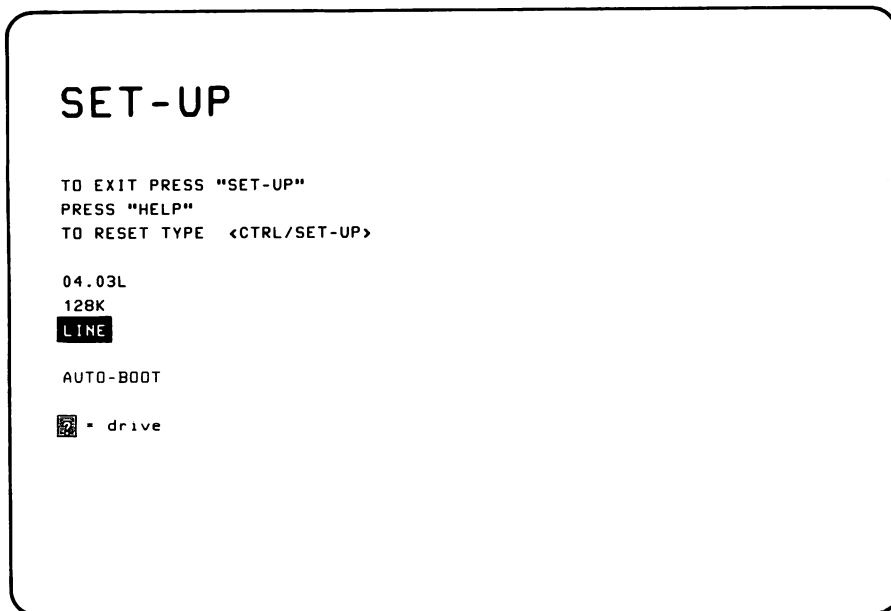

Figure 3-12. Set-Up Display – Auto-Boot

Saving Set-Up Values

IMPORTANT

To save the values you have selected in Set-Up, hold down the **Shift** key and type **S**. This action places the values you select in a memory that stores them for the computer when you turn the power off and on.

Recalling Set-Up Values

If you do not save the Set-Up values, the computer uses the new values temporarily until you:

- Change the Set-Up features again
- Turn off the computer

- Recall the original features by typing **Shift/R**.
- Run an application program that changes the features.

You can make temporary changes as often as you like, but the computer returns to its initial state whenever you turn off the power unless you save the changes by typing **Shift/S**. If you wish to return the computer to its original state without turning off the computer power, you can execute the Set-Up recall operation. To do this in Set-Up, you type **Shift/R**.

CAUTION

The recall operation erases any text that was on the screen before you entered Set-Up.

System Reset

While in Set-Up, you hold down the **Ctrl** key and press the **Set-Up** key to perform a system reset. The computer performs a brief selftest of its main memory, recalls its Set-Up features, and displays its Main System Menu (or automatically starts from the drive you selected with the Auto-Boot major heading).

If there is a problem and you can still operate the computer in one of its operating modes, either as a terminal or as a personal computer (but not both), the computer displays a message on the screen above the Main System Menu.

If only a message displays with no menu, you must find and correct the problem before continuing. See Appendix B for a list of messages and corrective actions.

4

Connecting a Printer to Your Rainbow Computer

Introduction

Digital Equipment Corporation offers you a choice of three printers for your Rainbow computer. Figure 4-1 illustrates these.

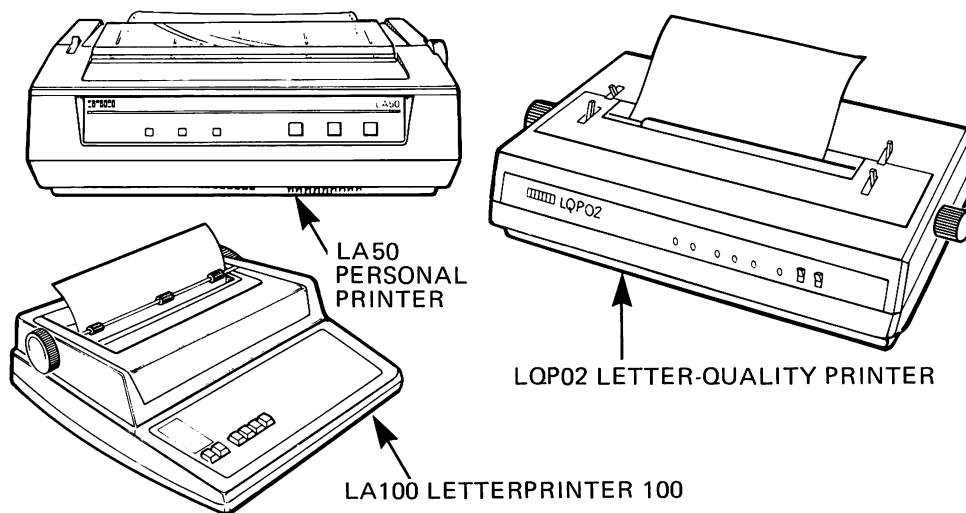

Figure 4-1. Digital's Personal Printers

Connecting a Printer to Your Rainbow Computer

These printers accept various types of paper, including fan-fold paper, multipart forms, roll paper, labels, and your own office stationery.

Each printer is easily connected to your Rainbow computer. Other serial printers with the same FCC rating can also be connected to the Rainbow computer. (See the notice on this manual's copyright page.)

The LA50 Personal Printer and the LA100 Letterprinter 100 can print the DEC Multinational Character set. Other Digital printers do not print foreign characters.

Connecting a Printer

You can connect each of these three printers to your Rainbow computer in three easy steps. The printer connector (labeled PRINTER) is a D-type, 25-pin, female connector on the back of the Rainbow system unit (Figure 4-2).

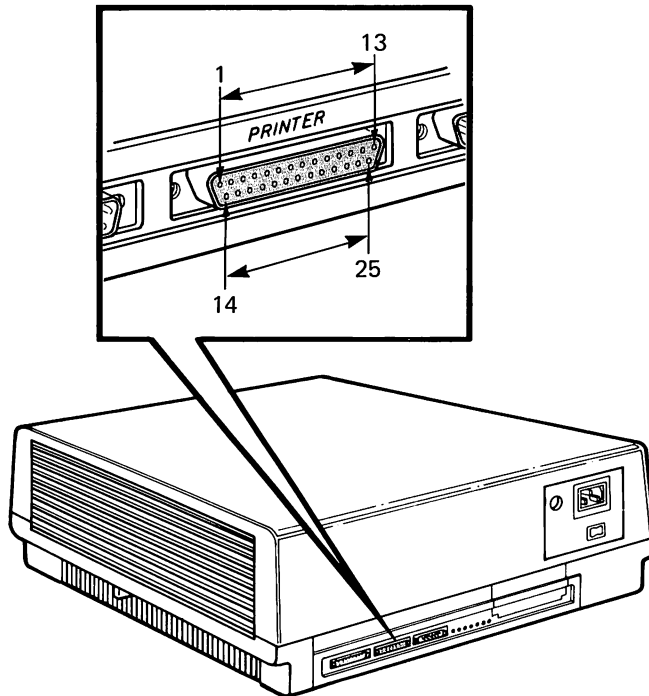

Figure 4-2. Printer Connector on the System Unit

Connecting a Printer to Your Rainbow Computer

1. Turn off the computer by setting the power switch on the system unit to 0.
2. Connect one end of the printer cable to the printer connector on the system unit and tighten the thumbscrews (Figure 4-3).
3. Connect the other end of the printer cable to the back of the printer and tighten the thumbscrews.

To complete the installation of your printer, refer to your printer's installation manual.

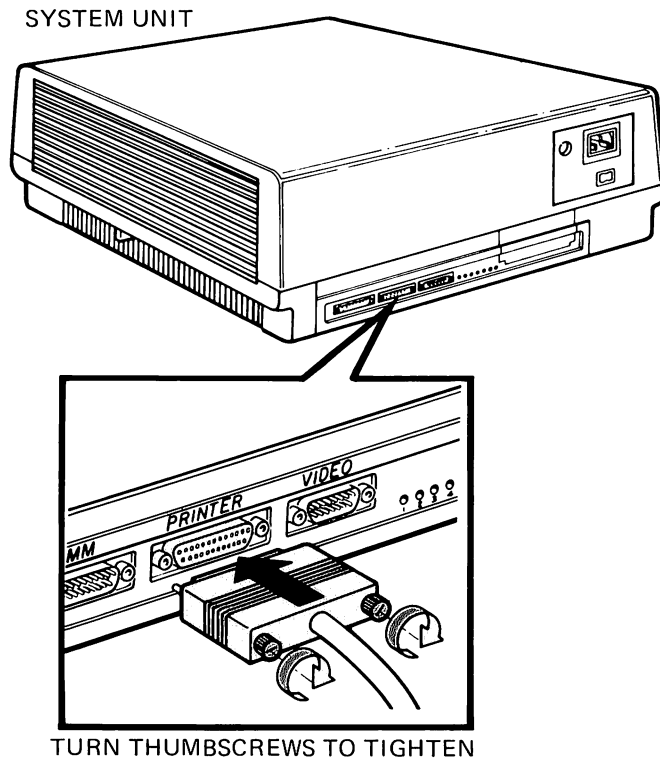

Figure 4-3. Connecting the COMM Cable to the Printer Connector

Printer Set-Up Selections

You can change the following selections in the Rainbow computer for different types of printers.

- Number of data bits per character – 7 or 8
- Parity – odd (O), even (E), mark (M), space (S), or none (N)
- Transmit/receive speed (baud rate)

Changing Data Bits and Parity

To change data bits and parity, turn on the Rainbow computer and wait until you see the Main System Menu. Press the **Set-Up** key, then press the **Next Screen** key until you see the PRINTER heading shown in Figure 4-4.

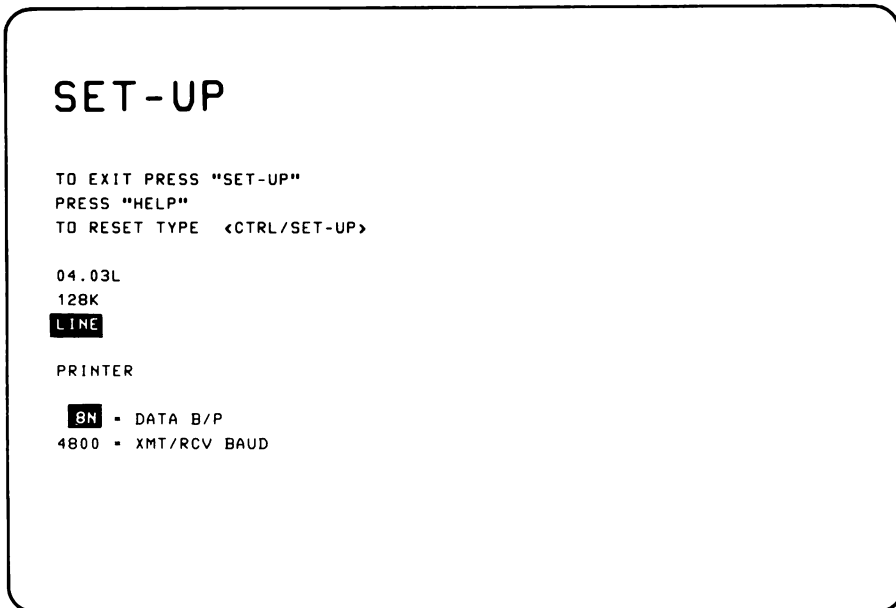

Figure 4-4. Set-Up Mode Showing Printer Heading

Digital Equipment Corporation's personal printers are enabled for eight data bits and no parity (8N). If you have a different printer, refer to its user's guide to check the settings; then, change the setting in your Rainbow computer to match that of your printer. Use the ↑ or ↓ key to change the setting. Other possible settings are listed in Table 4-1.

Table 4-1. Printer Data Bits and Parity Selections

Setting	Data Bits	Parity
7M	7	Mark
7S	7	Space
7O	7	Odd
7E	7	Even
7N	7	None
8O	8	Odd
8E	8	Even
8N	8	None

Changing Transmit/Receive Speed (Baud Rate)

To change the transmit/receive speed, press the → key to select the transmit/receive baud rate (XMT/RCV BAUD). The rate's current setting displays in reverse video on the screen. If you are using a printer other than one mentioned in this manual, check the printer's user's guide to find its standard transmit and receive speed. Press the ↑ or ↓ key to change this setting to match that of the printer. The following baud rates are supported.

75, 150, 300, 600, 1200, 2400, 4800, 9600

Press **Shift/S** to save these selections. Then, exit Set-Up by pressing the **Set-Up** key again.

Printer Connector Signals

The signals on the printer connector (Figure 4-2) meet the following standards.

- Electronic Industry Association (EIA) standard RS-423 and RS-232-C
- Consolidated Committee for International Telephone and Telegraph (CCITT), recommendation V.28

Table 4-2 lists the printer connector signals and their pin assignments. The table does not list the signals and pins the Rainbow computer does not use.

Table 4-2. Printer Connector Signals

Pin	Signal	Name	CCITT/EIA	Description
1	Protective Ground	PROT GND	101/AA	Chassis ground; ac power cord ground.
2	Transmitted Data (Input)	TXD	103/BA	Data transmitted from the printer to the Rainbow computer.
3	Received Data (Output)	RXD	104/BB	Data received by the printer from the Rainbow computer.
5	Clear to Send	CTS	106/CB	Always on.
6	Data Set Ready	DSR	107/CC	Upon power-up, the Rainbow computer turns this signal on.
7	Signal Ground	SGND	102/AB	Common ground for all signals.
20	Data Terminal Ready	DTR	108.2/CD	Indicates printer status. If printer turns off DTR, the Rainbow stops sending characters to the printer. When the printer turns on DTR, the Rainbow sends characters to the printer.

Using the Printer with a Remote Computer

If you use a printer when your Rainbow computer is connected to a remote computer, you may also need to change the following Set-Up features. (Refer to the remote computer's user's guide for the required information.)

Printer Communications Settings for the Rainbow Computer

Major Heading	Minor Heading
Parameter	New Line Mode Print Termination Character
Printer	Data Bits/Parity Transmit/Receive Baud Rates

Print Keys

Figure 4-5 illustrates the keys that control printing when you are using your Rainbow computer as a terminal.

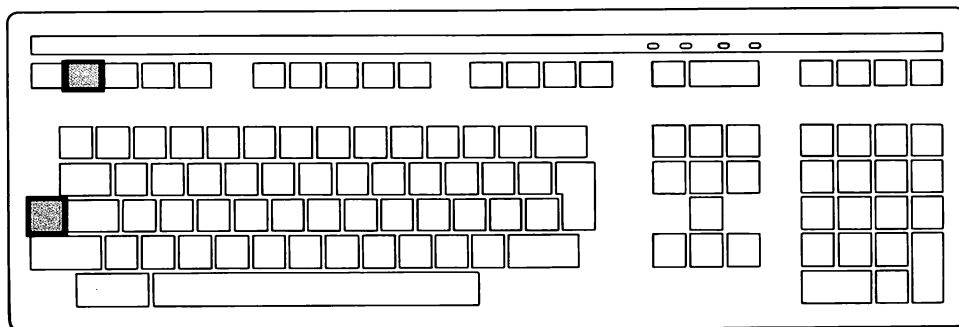

Figure 4-5. Print Keys

Print Commands

You use two commands to send text to a printer when you are using the Rainbow computer as a terminal.

Print Screen

You press the **Print Screen** key after you type your text to have the printer print only the text currently on the screen. You can use this command for printing short letters or memos.

Ctrl/Print Screen

To print a complete file, you use the **Ctrl** key and the **Print Screen** key together. To do this, follow the steps below.

1. Type in a command to display a file on the screen.
2. Press **Ctrl/Print Screen**.
3. Press **Return**. [This step assumes that you have set the New Line feature to 1 (New Line).]
4. To stop printing, press **Ctrl/Print Screen** again.

5

Communicating with Another Computer

Introduction

The Rainbow computer can communicate with another computer, called a remote computer, as shown in Figure 5-1. This communication can occur when the Rainbow computer is in terminal mode and when an application program is executing under an operating system. In terminal mode, the computer emulates a VT102 terminal. The Rainbow computer acts as a terminal by both transmitting keyboard entries to the remote computer and displaying characters received from the remote computer on the Rainbow monitor screen. With an application program, the Rainbow computer can communicate with another device such as a terminal or computer.

When you use the Rainbow computer as a terminal connected to a remote computer, you can:

- Access files on the remote computer
- Run programs on the remote computer
- Use the remote computer's networking services
- Use other services the remote computer provides
- Print what is displayed on the screen when a printer is connected.

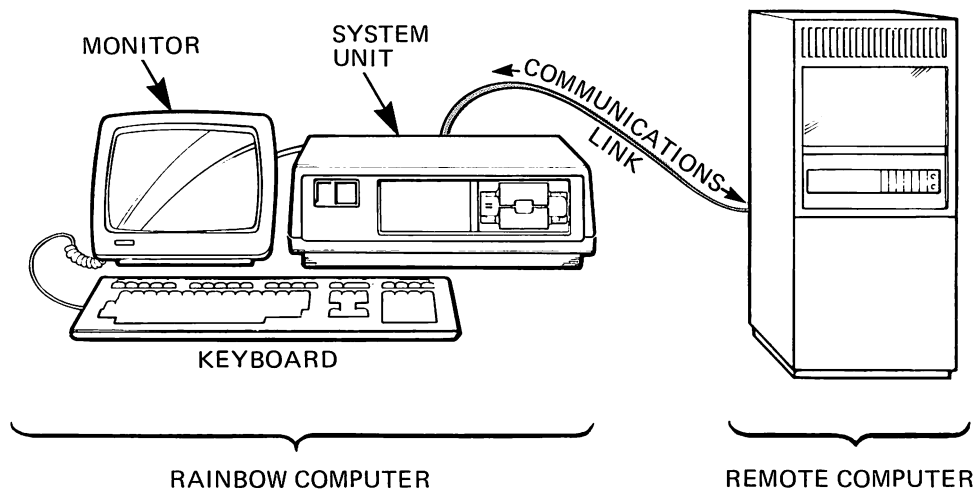

Figure 5-1. Rainbow Computer and Remote Computer Connection

You can use the Rainbow computer with a remote computer if the following criteria are met.

- The Rainbow computer must be in terminal mode. (Terminal mode is discussed later in this chapter.)
- The remote computer must support an ASCII terminal.
- The Rainbow computer must be connected either directly or through a telephone line to the remote computer.
- The Set-Up feature selections must be compatible with the remote computer or its application programs.

Refer to Chapter 3, Selecting Computer Features Using Set-Up.

Connecting the Rainbow Computer to a Remote Computer

You can use two methods to connect the Rainbow computer to a remote computer.

1. Direct connection (Figure 5-2). In this method, you connect the communications cable to the remote computer's cable. You may need special adapters to mate pins and to ensure proper signal connections.

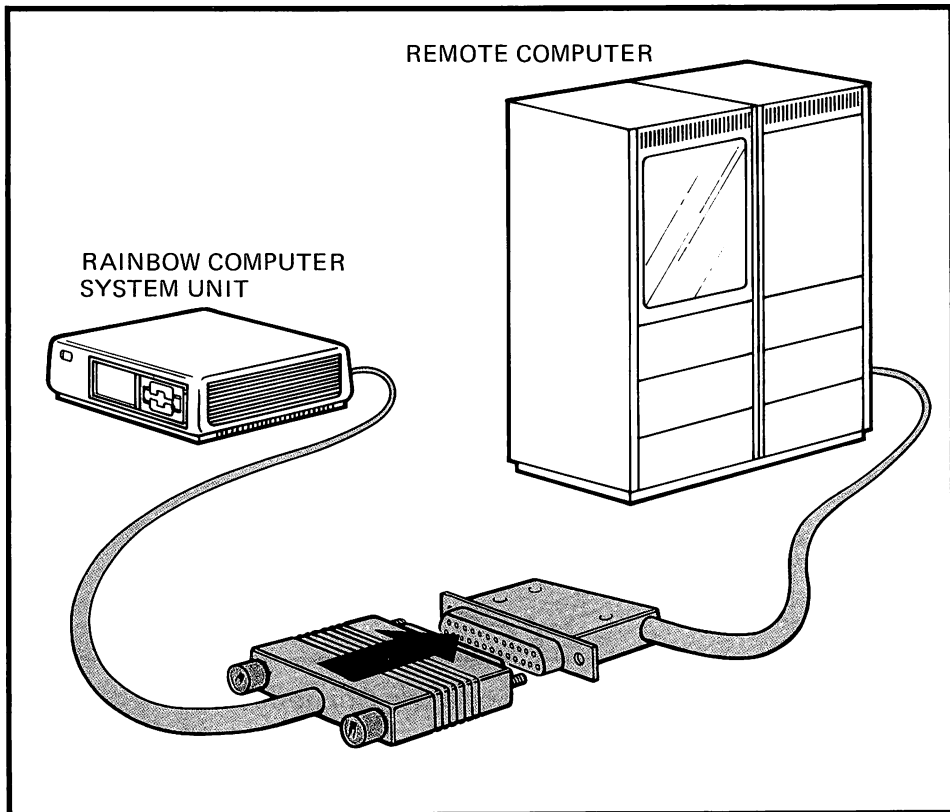

Figure 5-2. Direct Connection

2. Telephone line connection (Figure 5-3). In this method, you connect a communications cable to a modem (data set). The modem changes the signals produced by the Rainbow computer into signals that can be transmitted over the telephone line. Many types of modems are available, but the modems on both ends of the telephone line must be compatible with each other. Both computers must be set to enable the signals required by the modems.

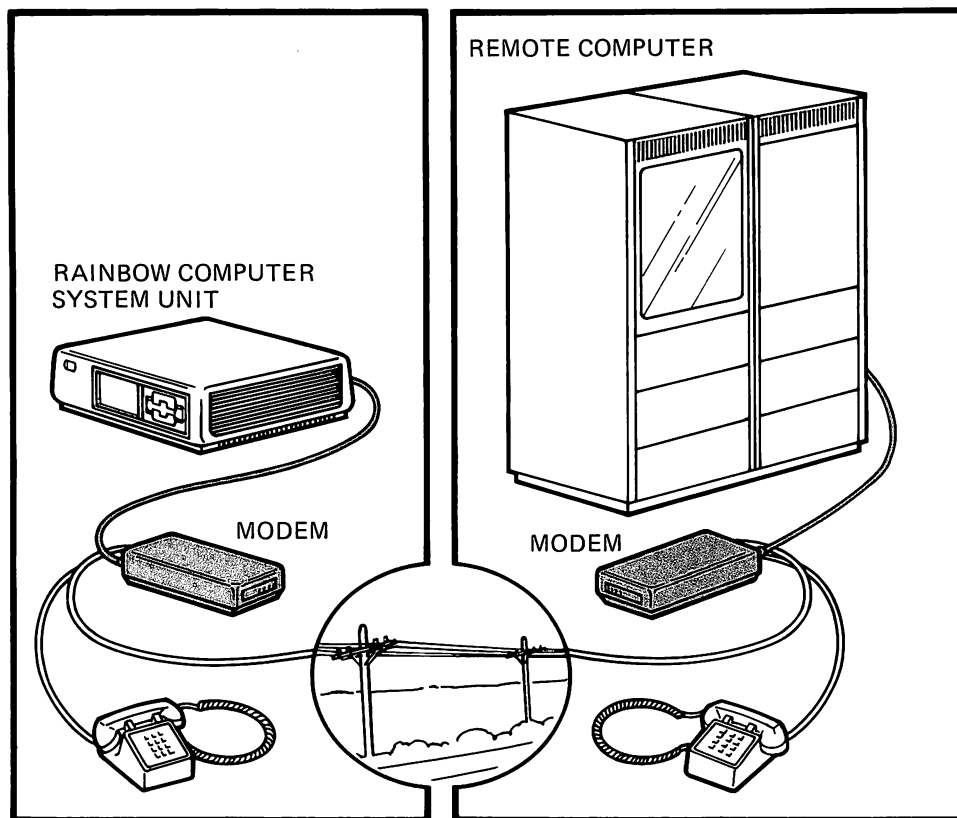

Figure 5-3. Telephone Line Connection

You use the communications connector (labeled COMM) on the back of the Rainbow system unit with both methods.

Cables

You can use the COMM cable that comes with your Rainbow computer for the direct connection method.

For the telephone line connection method, you may need an adapter to connect the modem cable.

- Asynchronous modem. Cables used with Bell System-type modems must have an RS-232 female connector on one end and a corresponding male connector on the other. The BCC04 COMM cable that comes with the Rainbow computer meets these requirements.
- Synchronous modem. Cables used with Bell System-type modems must have an RS-232 female connector on one end and a corresponding male connector on the other. Digital's BC224 modem cable meets these requirements. (Synchronous communications require a special application program.)

Procedure for Connection to a Remote Computer

Use the following procedure to connect a communications line to your Rainbow computer.

1. Turn off the Rainbow computer by setting the power switch on the system unit to 0.
2. Connect one end of the COMM cable to the communications connector (COMM) and tighten the cable's thumbscrews (Figure 5-4).
3. Connect the other end of the COMM cable to the cable coming from the modem, remote computer, or the appropriate adapter cable (Figure 5-5).
4. Check the dial-up procedures for your modem.
5. Turn on the Rainbow computer by setting the power switch to 1.

Changing Rainbow Set-Up Features to Communicate with a Remote Computer

For a Rainbow computer to communicate with a remote computer, you must select the Set-Up line feature. When you enter Set-Up, the system will display line or local on the screen. If local displays, type L to select line to communicate with a remote computer.

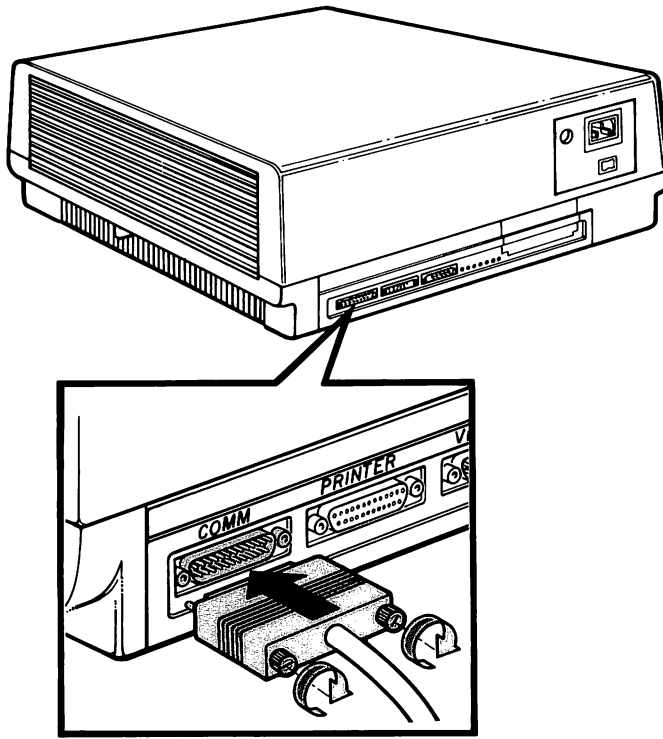

TURN THUMBSCREWS TO TIGHTEN

Figure 5-4. Connecting the COMM Cable to the Communications Connector

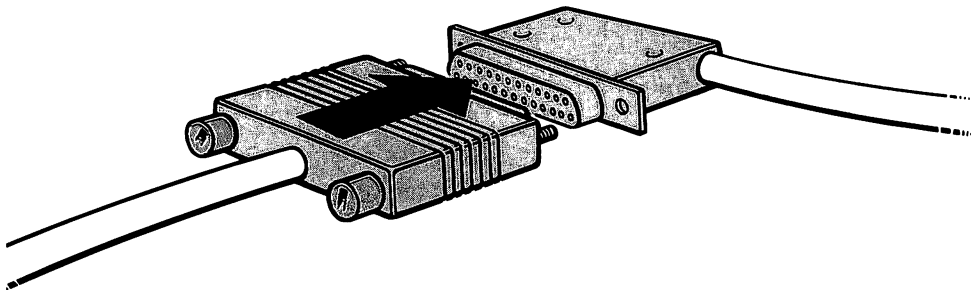

Figure 5-5. Connecting the COMM Cable to a Remote Computer Cable

The following Set-Up features of the Rainbow computer must also be compatible with those of the remote computer. Refer to the remote computer's user's guide for information on which settings you will need to change. Some settings may already be compatible, and you will not need to change them.

1. Parameter Settings
 - a. Auto-XON/XOFF
 - b. Local echo
 - c. Transmit break
 - d. Modem stop bits
 - e. Received character parity
 - f. Auto-answerback
 - g. Disconnect character use
 - h. Disconnect delay

2. Modem
 - a. Data bits/parity
 - b. Transmit baud rate
 - c. Receive baud rate
 - d. Protocol

Refer to Chapter 3, *Selecting Computer Features Using Set-Up*, to change these features.

The Modem Protocol Set-Up Feature

The Rainbow computer uses a full-duplex modem. A full-duplex modem transmits and receives characters at the same time.

The rules for communications, the signals used, and how the signals are interpreted all form the communications protocol. In the Rainbow computer you can select one of three communications protocols. These are shown in Table 5-1.

Table 5-1. Communications Protocols

Set-Up Selection	Description and Usual Application
FDXA	Full-duplex with limited modem control (data leads only). This is a direct connection to a remote computer or to a modem that uses limited modem control signals.
FDXB	Full-duplex with modem control. This is telephone line connection that uses full modem control signals.
FDXC	Asymmetrical full-duplex with modem control. Full-duplex communications with half-duplex modem using the secondary channel. FDXC requires a special cable.

Full-Duplex with No Modem Control (FDXA)

The FDXA selection allows the Rainbow computer to communicate by using limited modem control signals. The computer is ready to transmit or receive when you turn its power on and select the Set-Up line feature.

FDXA Connect Conditions. When you turn on the Rainbow, it enables the Data Terminal Ready and Request to Send modem control signals. Communication with the remote computer is then allowed.

FDXA Disconnect Conditions. The Rainbow computer disconnects the telephone line by turning off the Data Terminal Ready modem control signal. This signal is turned off when any of the following occurs.

- A disconnect character is received.
- A recall or system reset is executed.
- You type **Shift/Break** .

Full-Duplex with Modem Control (FDXB)

The FDXB selection allows the Rainbow computer to communicate with a modem that uses modem control signals. These control signals make sure that a connection occurs and is maintained before and during the communication process. Communication stops if the connection is not maintained.

FDXB Connect Conditions. The signals outlined in Table 5-2 must be enabled before communication is allowed.

Table 5-2. Modem Connect Conditions

Name	Signal	Source
CTS	Clear to Send	Modem
DSR	Data Set Ready	Modem
RLSD	Receive Line Signal Detector (Carrier Detector)	Modem
DTR	Data Terminal Ready	Rainbow Computer

FDXB Disconnect Conditions. The Rainbow computer disconnects the telephone line by turning off the Data Terminal Ready signal. This signal is turned off when any one of the following occurs.

- The Rainbow computer is placed in local mode.
- A recall or system reset is executed.
- You type **Shift/Break**.
- A disconnect character is received, and the disconnect character enable Set-Up selection is on.
- DSR is turned off at the modem.
- There is a loss of RLSD for a time more than allowed by the disconnect delay Set-Up selection.
- RLSD is not turned on within 30 seconds after DSR is turned on.

Asymmetrical Full-Duplex (FDXC)

With the FDXC selection, the Rainbow computer can use full-duplex communications on a half-duplex modem. The Rainbow computer receives characters on the primary channel and transmits characters on the secondary channel at 75 baud.

To use this protocol, the modem must support a secondary channel. This is accomplished through a special cable that redirects the secondary transmitting signals, leaving the modem to the Rainbow's primary transmitting signals.

The secondary signals from the modem are: SRTS; SCTS; and STXD. These are mapped to the primary side of the Rainbow computer: RTS; CTS; TXD.

FDXC Connect Conditions. The signals outlined in Table 5-2, Modem Connect Conditions, must be enabled before communication is allowed.

FDXC Disconnect Conditions. The Rainbow computer disconnects the telephone line by turning off the Data Terminal Ready signal. This signal is turned off under the same conditions specified for FDXB.

Auto-XON/XOFF

To provide for smooth communication with the remote computer, it is recommended that you have the auto-XON/XOFF Set-Up feature on. With this feature on, the Rainbow computer automatically sends an XOFF control character when it receives more characters than it can handle. The XOFF control character tells the remote computer to stop sending data. When the Rainbow computer can accept more data, it sends an XON control character to the remote computer to tell it to continue transmitting data.

Transmit Break

The transmit break Set-Up feature enables or disables the **Break** key. A Break signal is a transmitted space (0) condition that lasts 0.275 seconds ($\pm 10\%$) on the transmit data line. The remote computer's response to the Break signal depends on the type of computer and its software.

You can always perform a disconnect **Shift/Break** when the Rainbow computer is in terminal mode to turn off the Data Terminal Ready (DTR) and Request to Send (RTS) signals.

When you enable the disconnect character in Set-Up, the Rainbow computer transmits the disconnect character before it turns off the DTR and RTS signals.

Typing **Shift/Break** is the usual way to disconnect the Rainbow computer from its communications line.

Communications Connector Signals

The communications (COMM) connector signals meet the following standards.

- EIA RS-423 and RS-232-C
- CCITT recommendations V.21, V.22, V.23, V.24, and V.28

The COMM pin numbers are shown in Figure 5-6. The signals on each pin are listed in Table 5-3. This table also lists the signals used by each modem protocol. Signals and pins not listed are not used by the Rainbow computer.

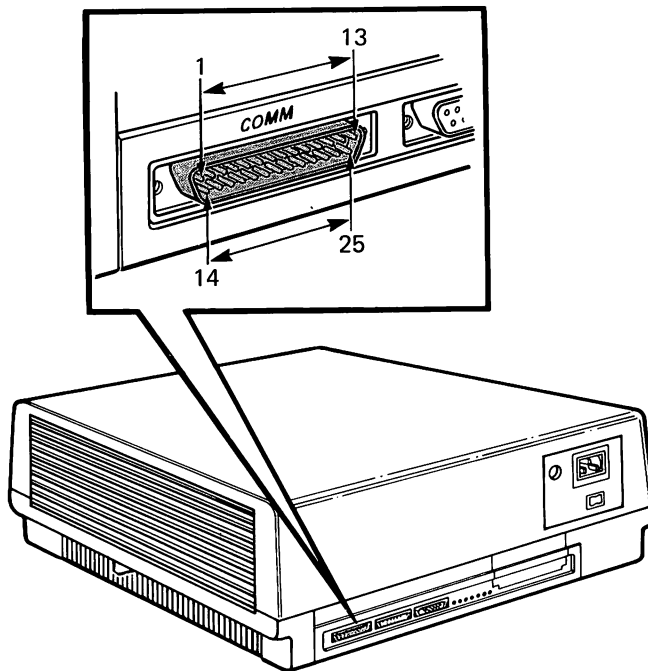

Figure 5-6. COMM Pin Numbers

Table 5-3. Communications Connector Signals

Pin	Signal	Name	CCITT/EIA	FDXA	FDXB	FDXC	Description
1	Protective Ground	PROT GND	101/AA	X	X	X	Chassis ground; ac power cord ground.
2	Transmitted Data	TXD	103/BA	X	X	X	Data transmitted from the Rainbow computer; asserted high (mark state) when not transmitting.
3	Received Data	RXD	104/BB	X	X	X	Characters received from the remote computer.

X = Used with this protocol selection.

*These signals are supported by using a special cable for FDXC modem protocol.

Table 5-3. Communications Connector Signals (Cont)

Pin	Signal	Name	CCITT/EIA	FDXA	FDXB	FDXC	Description
4	Request to Send	RTS	105/CA	X	X	X	On when the Rainbow computer is on-line, and off when off-line.
5	Clear to Send	CTS	106/CB	X	X	X	Indicates the modem is ready for transmission.
6	Data Set Ready	DSR	107/CC	X	X	X	Indicates the modem is in data mode.
7	Signal Ground	SGND	102/AB	X	X	X	Common ground for internal circuits (except protective ground).
8	Receive Line Signal Detector (Carrier Detect)	RLSD	109/CF	-	X	X	The modem turns this signal on when the carrier signal is of sufficient quality and magnitude.
12	Speed Indicator	SI	112/CI	-	X	-	When on, the transmit and receive speeds are 1200 baud; when off, these speeds are as established in Set-Up.
13	Secondary Clear to Send*	SCTS	121/SCB	-	-	X	When on, the modem is ready for the Rainbow computer to transmit data; when off, the modem is not ready.
14	Secondary Transmit Data*	STXD	118/SBA	-	-	X	Secondary channel information; same as Transmitted Data (TXD).
15	Transmitter Clock	TSET	114/DB	-	-	X	External clock from the modem.
17	Receiver Clock	RSET	115/DD	-	-	X	External clock from the modem.

X = Used with this protocol selection.

*These signals are supported by using a special cable for FDXC modem protocol.

Communicating with Another Computer

Table 5-3. Communications Connector Signals (Cont)

Pin	Signal	Name	CCITT/EIA	FDXA	FDXB	FDXC	Description
19	Secondary Request to Send*	SRTS	120/SCA	-	-	X	When on, the Rainbow computer is ready to receive characters; when off, the computer is ready to transmit characters. Same as Request to Send (RTS).
20	Data Terminal Ready	DTR	108.2/CD	X	X	X	When on, the Rainbow computer is ready to receive data; when off, this signal causes the modem to disconnect and not answer calls.
22	Ring Indicator	RI	125/CE	-	-	-	Ignored; used by the modem.
23	Speed Select	SPDS	111/CH	-	X	-	When on, the Rainbow computer's receive speed is greater than 600 baud; when off, the receive speed is equal to or less than 600 baud.

X = Used with this protocol selection.

*These signals are supported by using a special cable for FDXC modem protocol.

Using Terminal Mode

To use the Rainbow computer's terminal mode, select T from the Main System Menu (Figure 5-7).

In terminal mode, the Rainbow computer does not process certain Rainbow keys. These keys will beep when you press them. Keys in terminal mode are divided into three categories.

- Standard keys
- Function keys
- Print keys

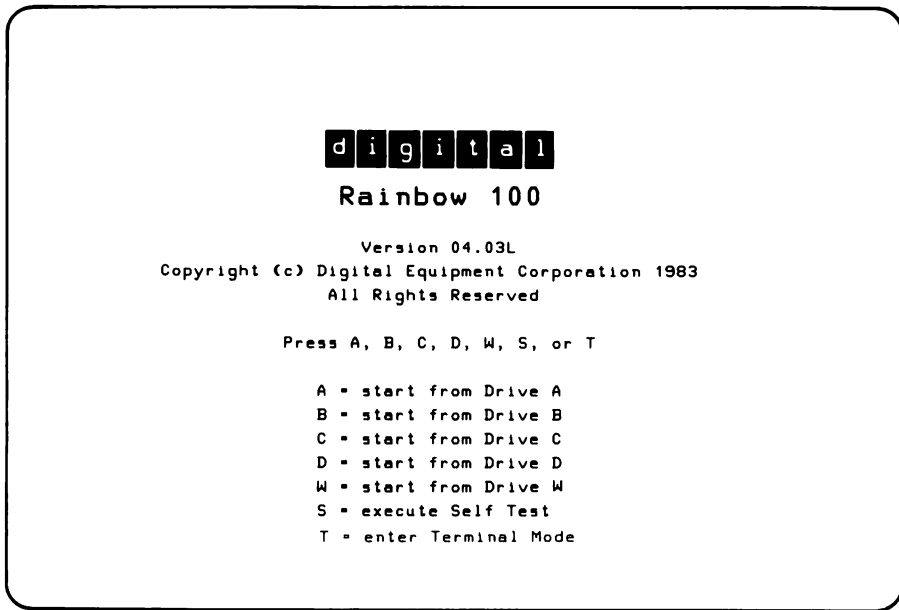

Figure 5-7. Rainbow Main System Menu

Standard keys (Figure 5-8) operate like the standard keys described in Chapter 2, The Rainbow Keyboard.

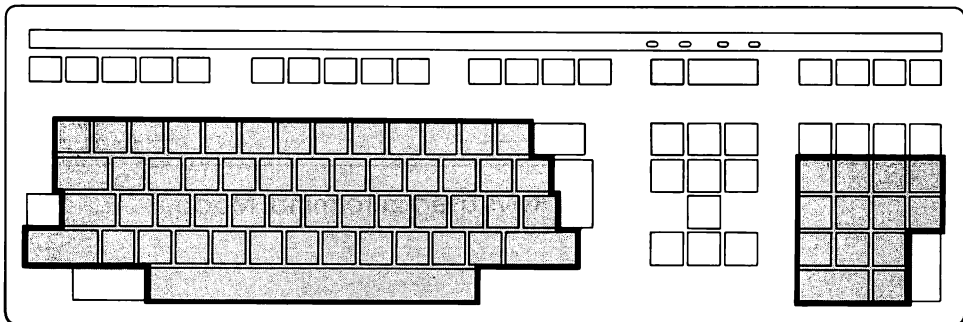

Figure 5-8. Standard Keys Used in Terminal Mode

Function keys (Figure 5-9) are defined by the remote computer's application programs.

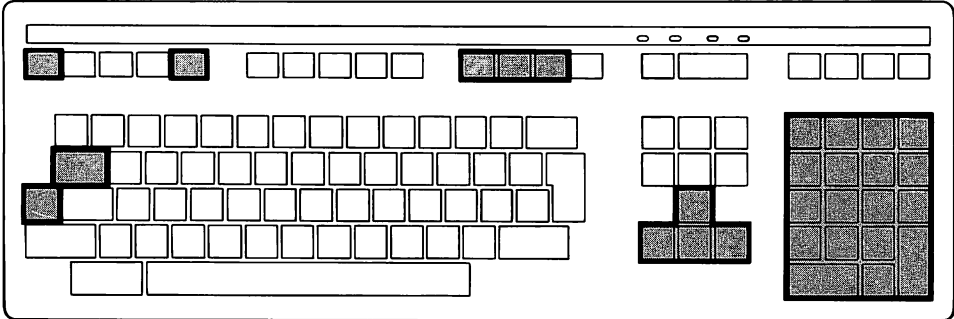

Figure 5-9. Function Keys Used in Terminal Mode

Print keys (Figure 5-10) control printing. To use the printer refer to Chapter 4, Connecting a Printer to Your Rainbow Computer.

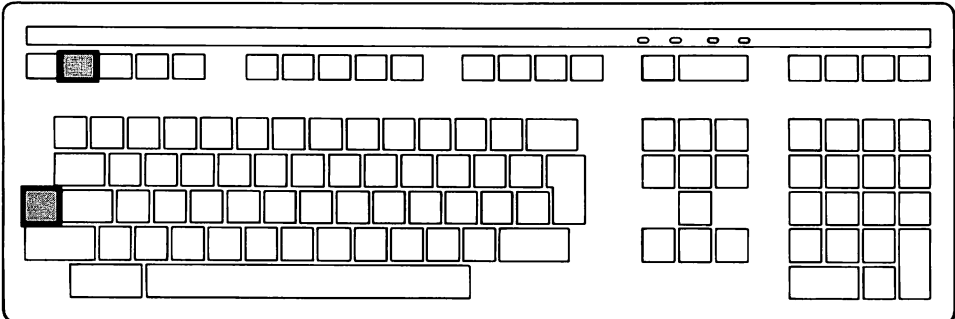

Figure 5-10. Print Keys Used in Terminal Mode

6

Rainbow Computer Tests

Diagnostic Tests

The Rainbow computer runs two types of diagnostic tests that detect and isolate problems that may occur in the system.

1. An internal diagnostic test runs when you turn on, reset, or select the selftest option from the Main System Menu.
2. A diskette diagnostic test runs when you decide to run a series of test programs that reside on a diskette.

Internal Diagnostic Test – Selftest

The internal diagnostic test runs automatically upon power-up and checks the internal logic of the system. If this test runs successfully, the computer will display the Main System Menu on the screen, as shown in Figure 6-1, and sound the computer bell tone once.

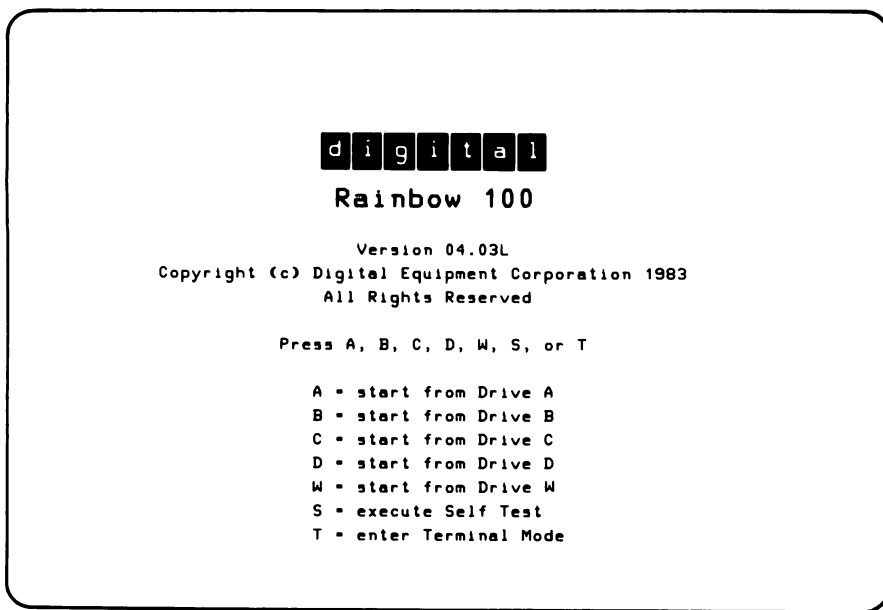

Figure 6-1. Main System Menu

When your Rainbow computer is set to auto-boot, the test is run before starting the selected boot-device and the computer will not display the Main System Menu.

If one bell tone sounds and you see a message in flashing reverse video above the Main System Menu, as shown in Figure 6-2, only one of the computer's operational modes is working. For example, if a diskette drive fails, you can still operate the Rainbow computer as a terminal connected to a remote computer. If the communications line fails, you can still operate the Rainbow computer as a personal computer. Appendix B lists the messages that could display when you turn on the computer.

If three bell tones sound, you will see a message but not the Main System Menu. In this case, you must find the cause of the problem before you can continue. Refer to Chapter 7 and Appendix B and try to isolate the cause of the problem before calling for service. The message will also be reported by the lights on the back of the system unit as shown in Figure 6-3.

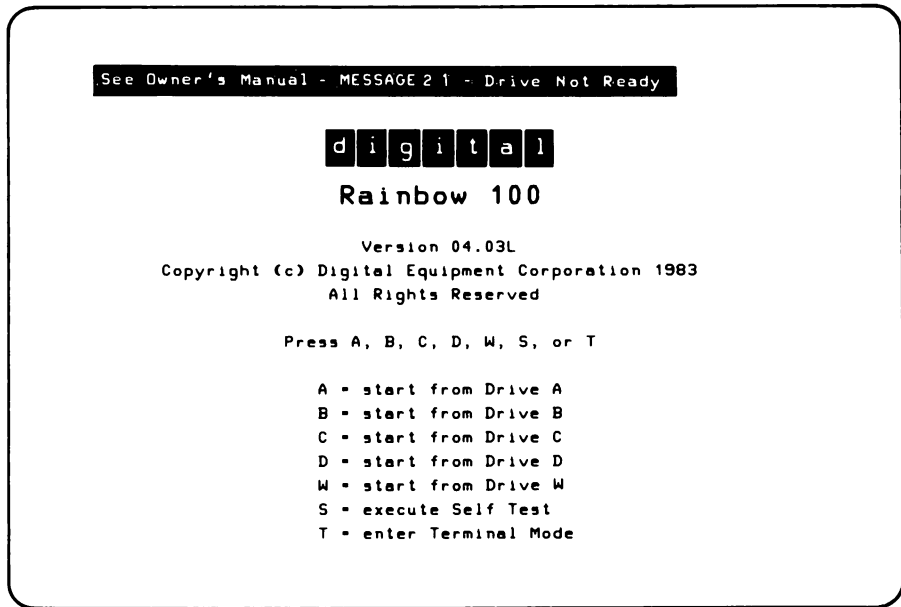

Figure 6-2. Main System Menu with Message

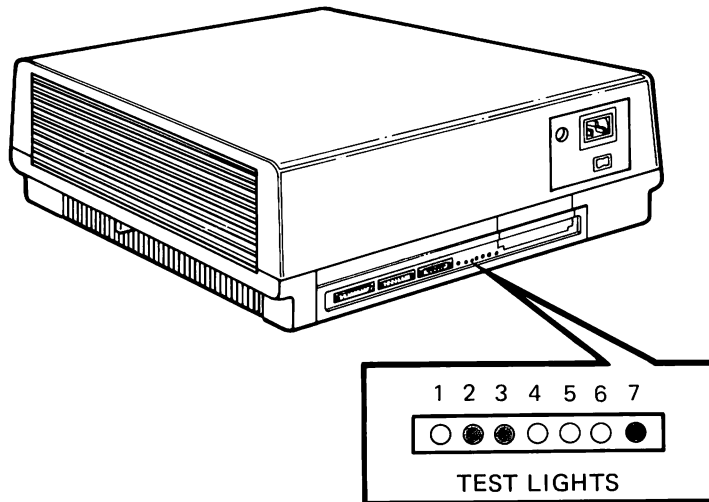

Figure 6-3. Example of a Message Displayed on the Lights at the Back of the System Unit

To run the internal diagnostic test, use the following procedure.

1. Without any diskettes in the diskette drives, set the power switch on the Rainbow computer to 1 (one). After a minute or two, depending on your computer's memory size, the computer displays the Main System Menu on your screen. (See Figure 6-1.)
2. Find two (2) blank diskettes with part number BL-N402A-BK printed on the diskette label (Figure 6-4).

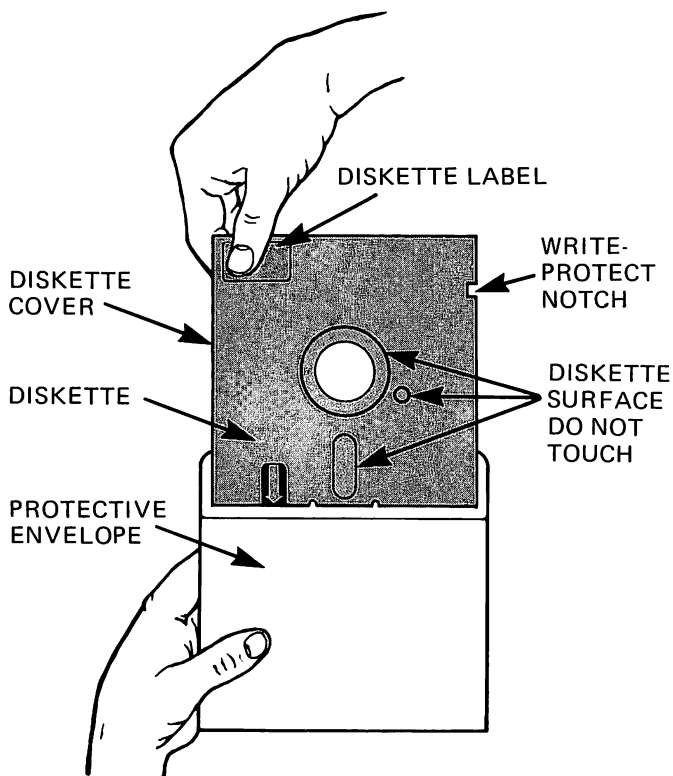

Figure 6-4. Blank Diskettes

NOTE

If your Rainbow computer is set to start automatically on a diskette drive, you will see the following message on your screen.

See Owner's Manual - MESSAGE 21 - Drive Not Ready

Disregard this message and continue with this procedure.

If your computer is set to start on the hard disk drive, you will have to set the auto-boot feature in Set-Up to "?" before continuing with this procedure.

3. Install diskettes.
 - a. Open diskette drive A and diskette drive B.
 - b. Insert a diskette in diskette drive A and close its door (Figure 6-5).
 - c. Insert a diskette in diskette drive B and close its door (Figure 6-5).
4. Type S.

TESTING. . .

will display on your screen. After about six minutes, if you have full memory installed in your Rainbow, you will hear a whir and a beep; then, you will see the Main System Menu. (If you have 128K of memory, you will hear the whir and beep in about one minute.) See Figure 6-1.

NOTE

If your computer is set to start automatically from a diskette drive, you will see the following message on your screen.

See Owner's Manual - MESSAGE 21 - Drive Not Ready

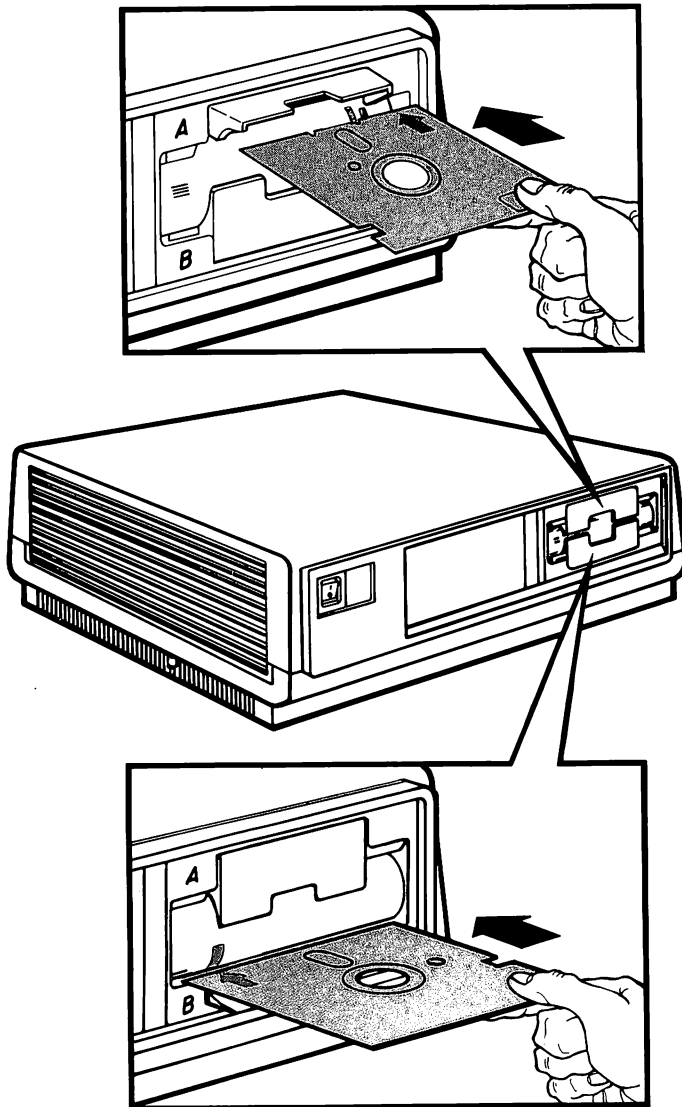

Figure 6-5. Insert Diskettes into Drives A and B

Diskette Diagnostic Test

The Rainbow diskette diagnostic test resides on one diskette. It comes in your Rainbow System Kit. The diagnostic runs the following four programs.

1. Test drives A and B.
2. Test computer – This test runs the drive test, a memory test, and a basic communications test.
3. Display individual test menu – This test selection allows you to run the previous tests one at a time. In addition, it allows you to run tests that check the communications connector, the printer connector, and options. This selection is meant to help isolate a problem to a specific device.
4. Install new diagnostic – This test selection allows you to add new diagnostic tests to the diskette when you add new options to your computer.

To add a new diagnostic test to your main diagnostic diskette you type **4**, press the **Return** key, and then follow the directions on your screen.

Loading the Diagnostic Diskette

To load the diagnostic diskette and select the desired test mode, follow the instructions below. Appendix B lists the messages for this diagnostic test.

After you turn on the computer and see the Main System Menu (Figure 6-1), insert the diagnostic diskette into drive A and close its door. (Note that the diagnostic diskette can be started from any diskette drive.)

Type **A** on the keyboard. The computer displays Main Diagnostic Menu, shown in Figure 6-6, on the screen.

Test Drives A and B

Check drives A and B by typing **1**, then pressing the **Return** key. Type the response printed in color below.

REMOVE DIAGNOSTIC DISKETTE AND INSERT SPARE DISKETTES
INTO DRIVES A/B **Return**

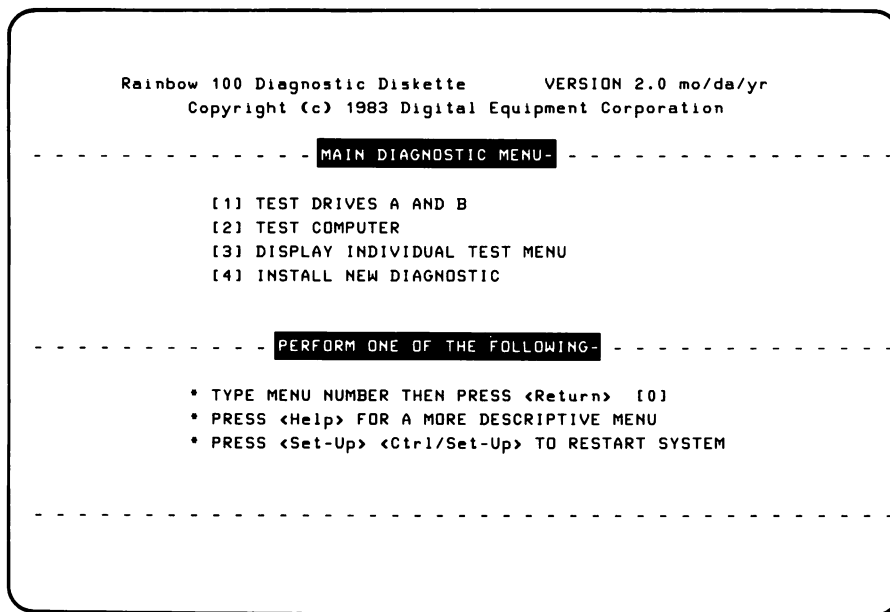

Figure 6-6. Main Diagnostic Menu

Remove the diagnostic diskette and insert blank or spare diskettes into drives A and B. Press the **Return** key.

NOTE

Make sure you insert the diskette correctly into the drive.

The following message displays on the screen.

```
***CAUTION***SPARE DISKETTE DATA WILL BE CHANGED!!!! 
```

NOTE

This means that any data on the spare diskettes will be destroyed.

Press the **Return** key if you want to continue.

The messages in Figure 6-7 display on your screen. If a problem is detected, a message displays on the screen. See Appendix B to isolate the cause.

```

                                DRIVES A AND B TEST
-----
***CAUTION*** SPARE DISKETTE DATA WILL BE CHANGED!!!!<Return>
NUMBER OF TESTS - 11
SUBTEST  1 - INTERNAL REGISTER           PASSED
SUBTEST  2 - HEAD LOAD TIMING            PASSED
SUBTEST  3 - INTERNAL LOOPBACK           PASSED
SUBTEST  4 - RESTORE                      PASSED
SUBTEST  5 - HEAD STEP                   PASSED
SUBTEST  6 - MOTOR SPEED                 PASSED
SUBTEST  7 - SEEKS                       PASSED
SUBTEST  8 - FORCED WRITE ERRORS         FAILED
SUBTEST  9 - WRITE SECTORS               PASSED
SUBTEST 10 - FORCED READ ERRORS          PASSED
SUBTEST 11 - READ SECTORS                PASSED
REWRITING SECTORS USED IN SUBTESTS
END OF TESTS.  REINSERT DIAGNOSTIC DISKETTE THEN PRESS <Return>
-----

FAILURE:  DRIVE A:  DISKETTE WRITE PROTECTED
*TYPE P TO PROCEED OR L TO LOOP ON ERROR.  THEN PRESS <Return>:P
*PRESS <Help> FOR MORE INFORMATION.

```

Figure 6-7. Drives A and B Test Messages

After successful completion of the Drives A and B test, you will see the following message on the screen under the Main Diagnostic Menu.

```
PREVIOUSLY RUN DRIVES A AND B TEST - PASSED
```

Test Computer (Extended Test)

Test the computer by typing **2**. The messages shown in Figure 6-8 begin to display on the screen. The subtest being executed is shown in reverse video.

After the Diskette Drives subtest is completed, reinsert the diagnostic diskette and press the **Return** key.

The subtests check each diskette drive, test the memory, and check the communications and printer connectors. An execution count number or a subtest execution time displays on the screen. The message PASS or FAIL displays on the screen after each test is completed, as shown in Figure 6-8.

```

DISK DRIVES          PASS  VIDEO          ....
MEMORY (8088)         ....  COMM/PRINTER/KEYBOARD  ....
MEMORY (Z80)          ....  MEMORY (8088/Z80)      ....
MEMORY (SET-UP)       ....  SYSTEM INTERACTION     ....
.....
COMPUTER TESTS
NUMBER OF TESTS - 11
SUBTEST 1 - INTERNAL REGISTER          PASSED
SUBTEST 2 - HEAD LOAD TIMING           PASSED
SUBTEST 3 - INTERNAL LOOPBACK          PASSED
SUBTEST 4 - RESTORE                    PASSED
SUBTEST 5 - HEAD STEP                  PASSED
SUBTEST 6 - MOTOR SPEED                PASSED
SUBTEST 7 - SEEKS                      PASSED
SUBTEST 8 - FORCED WRITE ERRORS        PASSED
SUBTEST 9 - WRITE SECTORS              PASSED
SUBTEST 10 - FORCED READ ERRORS        PASSED
SUBTEST 11 - READ SECTORS              PASSED
REWRITING SECTORS USED IN SUBTESTS
END OF TESTS. REINSERT DIAGNOSTIC DISKETTE THEN PRESS <Return>
.....
```

Figure 6-8. Test Computer Messages

After completion of the computer tests, you will see the following message on the screen after the Main Diagnostic Menu.

PREVIOUSLY RUN COMPUTER TEST - PASSED (or FAILED)

Proceeding from an Error

If the system detects an error during a diagnostic test, it displays the following message after the FAILED message.

*TYPE P TO PROCEED OR L TO LOOP ON ERROR,
THEN PRESS **Return**
*PRESS **Help** FOR MORE ERROR INFORMATION.

Typing **P** causes the next subtest to run. If you have proceeded from an error, at the completion of all subtests the Main Diagnostic Menu appears followed by:

PREVIOUSLY RUN COMPUTER TEST - FAILED

If you type **L**, the message

```
-LOOPING ON ERROR: % ERROR = nnn
```

replaces the previous message. After the test is performed 10 times, the percent error is updated.

After correcting the problem, run the specific test that failed from the Individual Test Menu.

Display Individual Test Menu

You select **3** from the Main Diagnostic Menu and press the **Return** key to have the computer display the Individual Test Menu on the screen, as shown in Figure 6-9.

Type the number of the test you want to run and press the **Return** key. Follow the instructions displayed on the screen for that test.

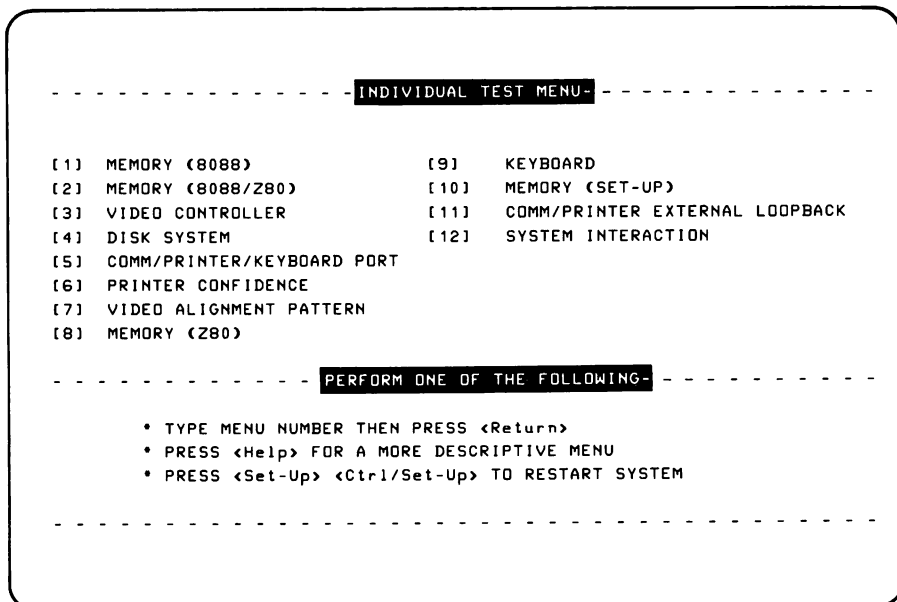

Figure 6-9. Individual Test Menu

After the individual test you selected completes, the system will display one of the following messages on the screen under the Main Diagnostic Menu.

PREVIOUSLY RUN INDIVIDUAL TEST -- PASSED

PREVIOUSLY RUN INDIVIDUAL TEST -- FAILED

Video Controller Test

This test is a series of displays, each of which displays on the screen for 20 seconds.

To begin the displays, press the **Resume** key. To hold a display, press the **Interrupt** key. To continue to the next display, press the **Resume** key.

Printer Confidence Test

The printer confidence test allows you to send a message of any length to the printer and verify that the printer received your message. The test requests that you input a message. To start printing your message, press the **Escape** key [(ESC) on the keyboard label strip]. The message is then sent to the printer continuously. To stop the test, press the **Escape** key or the **Return** key twice.

Video Alignment Pattern

The video alignment pattern test fills the printing area of your screen with E's so that you can check its alignment of characters with the video alignment template (Digital part number, 29-24371). To exit the test, press the **Return** key.

Keyboard Test

The keyboard test displays a layout of the keyboard on the screen. As you press each key, the displayed pattern of that key disappears (and reappears when pressed again) to confirm that the key is working correctly. Certain keys respond differently as follows.

- Pressing the **Hold Screen** key lights the Hold Screen light.
- Pressing the **Set-Up** key causes the computer to enter Set-Up mode.
- Pressing the **Lock** key lights the Lock light on the keyboard and prevents the monitor from responding to the other keys.
- To check the **Ctrl** or **Shift** keys, hold key down and press any other key.

You type **OUT** to return to the Main Diagnostic Menu.

7

Troubleshooting

Introduction

This chapter gives troubleshooting information that will help you isolate and solve some problems in your Rainbow computer. Use the following procedure if the computer does not respond correctly after you install it or if it reports a message.

Troubleshooting Procedure

Refer to Table 7-1 to find a symptom of the problem. Listed with each symptom are one or more of its possible causes and the corrective actions you can take to fix them.

If a message occurs during power-up, refer to Appendix B to determine a corrective action.

Table 7-1. Troubleshooting Procedure

Symptom	Probable Cause	Corrective Action
No response when the power switch is set to on (1).	Brightness or contrast controls need adjustment.	Adjust brightness and contrast controls on the back panel of the monitor.
	The system unit is not plugged in; no power from the wall receptacle.	Plug the power cord into the back of the system unit and the wall receptacle. Use a different socket to check if there is no power.
	Circuit breaker	Push in the circuit breaker on the back of the system unit. If the circuit breaker comes out again, there is a possible short circuit in the system. Call Digital Field Service.
	Power cord	Check the power cord for possible damage. Replace the power cord if necessary.
The computer powers up and sounds 2 bell tones. A message displays on the screen, along with the Main System Menu.	The computer has a nonfatal error; one of its operational modes is not working.	Check the message in Appendix B for its corrective action.
The computer powers up and sounds 3 bell tones. A message may or may not display on the screen.	The computer uncovered a problem during its power-up sequence, and the problem must be found before continuing.	Reset the system and try again. If 3 bell tones sound again, check the screen for a message. If no message appears, check the lights at the back of the system unit. They may point to the location of the problem. (See Appendix B.)
Wrong characters display on the screen while typing on the keyboard.	The following Set-Up features may be set incorrectly. <ul style="list-style-type: none"> • ANSI/VT52 • US/UK character set 	Check these Set-Up features. (See Chapter 3.)

Table 7-1. Troubleshooting Procedure (Cont)

Symptom	Probable Cause	Corrective Action
Wrong characters are being received by the Rainbow computer.	<p>The following communications Set-Up features, which are to match incoming data, may be set incorrectly.</p> <ul style="list-style-type: none"> • Modem receive baud rate • Data bits/parity • Modem protocol • Modem stop bits • ANSI/VT52 • Auto-wrap • New line mode • Received parity check 	Check these Set-Up features. (See Chapter 3.)
The substitution character (␣) displays on the screen instead of the character expected (or as typed on-line with a remote computer).	<p>Parity Set-Up feature is set incorrectly.</p> <p>XON/XOFF is not supported by the remote computer or is not turned on.</p> <p>Transmit or receive baud rate is set incorrectly.</p>	Check these Set-Up features. (See Chapter 3.)

Appendices

A

Rainbow Computer Specifications

Rainbow Computer System Specifications

Standard system:	System unit, keyboard, monitor, and operating system
System unit:	
Processors	Z80A and 8088 processors
Memory for programs	128K bytes (basic system) Expandable to 896K bytes
Printer connector	Serial, RS-423
Communications connector	Speeds up to 19,200 baud with modem control
Storage	Dual-diskette drive (2 × 400K bytes)

Rainbow Computer Specifications

Video output:	Monochromatic, RS-170 compatible
Environment:	Class A: air-conditioned office or light assembly area
Temperature	
Operating*	15° C to 32° C (59° F to 90° F)
Not operating	– 34° C to 60° C (– 29° F to 140° F)
Relative humidity	
Operating	20% to 80% with maximum wet bulb 25° C (77° F) and minimum dew point 2° C (36° F)
Not operating	5% to 95% (noncondensing)
Altitude (maximum)	
Operating	2.4 km (8,000 ft)
Not operating	9.1 km (30,000 ft)
Magnetic field	The RX50 diskette may lose data when exposed to a magnetic field strength of 50 oersteds or more.
System expansion:	Three dedicated spaces for option modules that are user-installable
Hardware options:	
Additional memory	64K or 256K bytes Expandable to 768K bytes

* Maximum allowable temperature is reduced by 1.8° C per 1000 m (1° F per 1000 ft) above sea level. Example: At 2.4 km (8000 ft), the maximum temperature is 27.5° C (82° F).

Second dual-diskette drive (2 × 400K bytes)

Hard disk (10 megabytes)

Extended communications

Color monitor

Color/graphics

Printer

You may use any serial printer with the same FCC classification as the Rainbow computer, such as the LA50 Personal Printer, LA100 Letterprinter 100, or LQP02 Letter-Quality Printer

Floor stand

Monitor Specifications

Characters: 7 × 9 dash matrix; includes 2 descenders

Format: 24 lines × 80 or 132 characters

Physical description:

Height	29.2 cm (11.5 in)
Width	34.9 cm (13.75 in)
Depth	31.1 cm (12.25 in)
Weight	6.4 kg (14 lb)
Cord	1.9 m (6 ft)

Adjustable tilt: +5 to -25 degrees

Video format: Monochromatic, composite

Keyboard Specifications

Audio and visual indicators:	4 lights and bell tone generator
Cord:	1.9 m (6 ft) coiled cord; 4-pin, telephone-type modular connectors; plugs into back of monitor
Physical description:	Low-profile, detachable
Height	5 cm (2.0 in) at highest point
Length	53.3 cm (21 in)
Width	17.1 cm (6.75 in)
Weight	2 kg (4.5 lb)
Keypad:	Sculptured key array
Home row key height:	3 cm (1.2 in) above desktop
Keys:	105 keys; matte, textured-finished, concave surface
Size (each)	1.27 cm (0.50 in) square
Spacing	1.9 cm (0.75 in) center-to-center (single-width keys)
Wobble	Less than 0.5 mm (0.020 in)
Force to activate	53 g to 79 g (1.8 oz to 2.7 oz); space bar is double this amount
Travel to activate	Less than 0.3 cm (0.12 in)
Numeric keypad:	18 keys
Function keys:	36 keys; firmware- and software-driven; 20 function keys horizontally positioned below label strip

Power: + 12 V \pm 5% @ 400 mA, 4.8 W
maximum

System Unit and Power Supply Specifications

Physical description:

Height	16.5 cm (6.5 in)
Length	48.3 cm (19 in)
Width	36.3 cm (14.3 in)
Weight (maximum)	13.6 kg (30 lb)

Power supply type: Transistor, switching-type AC-to-DC converter

AC input: Switch-selectable

115 V (nominal)	Single-phase, 3-wire, 90 V to 128 V rms; 47 Hz to 63 Hz line frequency
-----------------	---

230 V (nominal)	Single-phase, 3-wire, 174 V to 256 V rms; 47 Hz to 63 Hz line frequency
-----------------	--

Line current: 3 A @ 115 Vac
1.5 A @ 230 Vac

AC power consumption: 237 W

Regulated voltages + 5.1 V \pm 5%
+ 12.1 V \pm 5%
- 12 V \pm 7%

Circuit protection: Circuit breaker, externally accessible

RX50 Dual-Diskette Drive Specifications

Performance:

Diskettes per dual-diskette drive	2
Number of recording surfaces per diskette	1
Storage capacity per diskette (80 tracks)	400K (409,600) bytes
per track (10 sectors)	5,120 bytes
per sector	512 bytes
Transfer rate	250 bits/s
Average access time	290 ms

Functional Specifications:

Rotational speed	300 r/min
Density	96 tracks per inch

Physical Specifications:

Height	8.4 cm (3.3 in)
Width	14.7 cm (5.8 in)
Depth	21.6 cm (8.5 in)
Weight	1.7 kg (3.8 lb)

B

Rainbow Messages

Introduction

Rainbow messages are divided into two categories.

1. Internal diagnostic test messages
2. Diskette diagnostic test messages

Internal Diagnostic Test Messages

Internal Diagnostic test messages can occur during power-up, reset, or self-test. The computer displays these messages on your screen, and on the lights on the back of the system unit (Figure B-1). The sequence of these lights indicates a certain message.

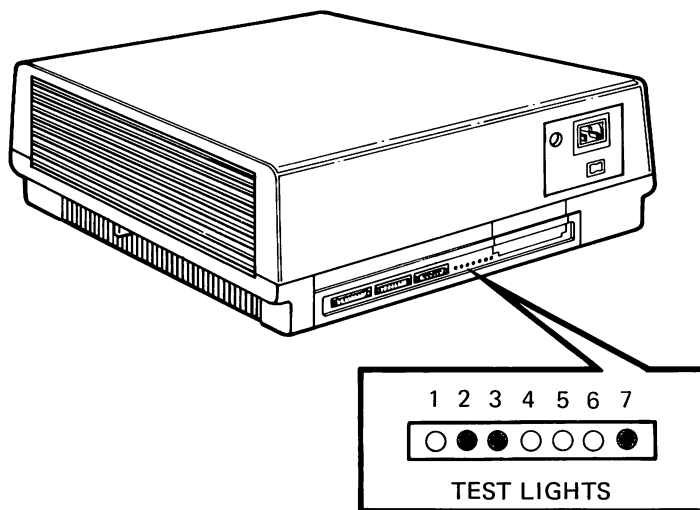

Figure B-1. Example of a Light Display on the Back of the System Unit

Table B-1 lists the internal diagnostic messages. If the computer displays a message on your screen, find the message in Table B-1 then, refer to the page number in this owner's manual that the table references after each message for further information. You can also press the **Help** key on the keyboard for more information on isolating the problem. Messages that require similar corrective action have been grouped together in the explanatory paragraphs that follow.

Drive A (or B as appropriate) – Messages 3, 6

These messages display when you run the extended selftest program if the diskette is write-protected, is inserted incorrectly in the drive, or is for a computer other than a Rainbow computer. Reinsert the diskette correctly into the drive; then, run the selftest program again.

If the message persists, insert another diskette into the drive and run the self-test program again.

Table B-1. Internal Diagnostic Test Messages

Message Number	Message See Owner's Manual followed by:	Tested During:			Light Display							Fatal***	See Owner's Manual† Page Number	
		Power- Up	Reset	Self- test	1	2	3	4	5	6	7			
1	Main Board	Yes	No	Yes	0	●	●	●	●	●	●	●	Yes	114
2	Main Board*	Yes	Yes	Yes	●	●	●	●	●	0	0	0	Yes	114
3	Drive A (or B)	No	No	Yes	0	0	●	●	●	●	●	No	104	
4	Drive A (or B)	No	No	Yes	●	●	0	0	●	●	●	No	110	
5	Drive A (or B)	No	No	Yes	0	●	0	0	0	●	●	No	110	
6	Drive A (or B)	No	No	Yes	●	0	0	0	0	●	●	No	104	
7	Drive A (or B)	Yes	No	Yes	0	●	●	●	●	●	●	No	109	
8	Drive A (or B)	Yes	No	Yes	●	0	●	●	●	●	●	No	109	
9	System Load Incomplete	No**	No	No	0	0	0	0	0	0	0	No	118	

NOTES:

● = On, 0 = Off, - = On or Off;

Cond. = Conditional.

*These errors can occur at any time because their circuits are monitored constantly.

**May occur during power-up if auto-boot is selected.

***Fatal means that you cannot use the Rainbow computer until the problem is found and corrected.

†You can find the procedures to remove and replace the field replaceable units in the *Rainbow™ 100 User's Service Guide*, EK-P100E-SV.

Table B-1. Internal Diagnostic Test Messages (Cont)

Message Number	Message See Owner's Manual followed by:	Tested During:			Light Display 1 2 3 4 5 6 7	Fatal***	See Owner's Manual† Page Number
		Power- Up	Reset	Self- test			
10	Main Board	Yes	No	Yes	●●●●●●●	Yes	114
11	System Load Incomplete	No**	No	No	○○○○○○○	No	118
12	Drive A (or B)	No	No	Yes	○○○○●●●	No	111
13	Keyboard	Yes	Yes	Yes	●●●●○○○	Yes	113
14	Main Board	Yes	No	Yes	●●●●●●●	No	114
16	Interrupts Off*	Yes	Yes	Yes	●●●○○○○	Cond.	112
17	Main Board	Yes	Yes	Yes	●●●●●○○	Yes	114
18	Main Board	Yes	Yes	Yes	●●●●○○●	Yes	114
19	Main Board	Yes	Yes	Yes	--- ●●○○	Yes	114
20	Main Board*	Yes	Yes	Yes	●●●○○○○	Yes	114
21	Drive Not Ready**	No**	No	No	○○○○○○○	No	111
22	Remove Card or Diskette	Yes	Yes	Yes	○○○○○○○	No	117
23	Non-System Diskette	No**	No	No	○○○○○○○	No	117
24	New Memory Size = nnnK	Yes	No	No	○○○○○○○	No	117

Table B-1. Internal Diagnostic Test Messages (Cont)

Message Number	Message See Owner's Manual followed by:	Tested During:			Light Display							Fatal***	See Owner's Manual† Page Number	
		Power-Up	Reset	Self-test	1	2	3	4	5	6	7			
25	Set-Up Defaults Stored	Yes	Yes	Yes	o	o	o	o	o	o	o	o	No	118
26	Main Board	Yes	No	Yes	o	o	o	o	o	o	o	o	Yes	114
27	Memory Board	No	No	Cond.	-	-	-	o	o	o	o	No	116	
28	RX50 Controller Board	Yes	No	Yes	o	o	o	o	o	o	o	o	No, but you cannot use a diskette; use in terminal mode only	117
29	Main Board*	Yes	Yes	Yes	o	o	o	o	o	o	o	o	No	115
30	Main Board	Yes	No	Yes	o	o	o	o	o	o	o	o	Yes	114
31	Main Board	Yes	No	Yes	o	o	o	o	o	o	o	o	Yes	114
33	Main Board	Yes	No	Yes	o	o	o	o	o	o	o	o	Yes	114

NOTES:

● = On, o = Off, - = On or Off;

Cond. = Conditional.

*These errors can occur at any time because their circuits are monitored constantly.

**May occur during power-up if auto-boot is selected.

***Fatal means that you cannot use the Rainbow computer until the problem is found and corrected.

†You can find the procedures to remove and replace the field replaceable units in the *Rainbow™ 100 User's Service Guide*, EK-P100E-SV.

Table B-1. Internal Diagnostic Test Messages (Cont)

Message Number	Message See Owner's Manual followed by:	Tested During:			Light Display 1 2 3 4 5 6 7	Fatal***	See Owner's Manual† Page Number
		Power-Up	Reset	Self-test			
40	Main Board	Yes	No	Yes	● o ● ● o ● o	No, but you cannot use the printer	115
50	Main Board	Yes	No	Yes	o o ● ● o ● o	Yes	114
60	Main Board	Yes	No	Yes	o ● ● ● o ● o	No, but terminal mode is not operational	116

NOTES:

● = On, o = Off, - = On or Off;
Cond. = Conditional.

*These errors can occur at any time because their circuits are monitored constantly.

**May occur during power-up if auto-boot is selected.

***Fatal means that you cannot use the Rainbow computer until the problem is found and corrected.

†You can find the procedures to remove and replace the field replaceable units in the *Rainbow™ 100 User's Service Guide*, EK-P100E-SV.

Make sure the drive cables are installed properly. If the message still occurs, replace the parts in the following order:

- Diskette drive
- Diskette drive cable
- RX50 controller module

You can do this by:

- Reporting the problem to your vendor
- Reporting the problem to the Digital Customer Help Line
800-DEC-8000
- Ordering the part and installing it yourself using the *Rainbow™ 100 User's Service Guide*. (The part number for this guide is EK-P100E-SV.)

Drive A (or B as appropriate) – Messages 7,8

These messages display when you turn on the Rainbow computer. You cannot use the Rainbow computer as a personal computer until you correct the problem. However, you can use it as a terminal. To correct the problem, turn the computer off and on again.

Make sure that the diskette drive cables are installed properly. If the error still persists, replace the drive by:

- Reporting the problem to your vendor
- Reporting the problem to the Digital Customer Help Line
800-DEC-8000
- Ordering the part and installing it yourself using the *Rainbow™ 100 User's Service Guide*. (The part number for this guide is EK-P100E-SV.)

Drive A (or B as appropriate) – Message 4

This message displays when you run the extended selftest program if the diskette in the drive is unreadable. The diskette may be bent and slowing down the drive motor, or the motor may be running too fast. To correct the problem, check the diskette for creases, smears, or dirt. If you find none, reinsert the old diskette. If you find a problem, insert another diskette into the drive; then, run the selftest program again.

If the problem persists after trying several diskettes, replace the diskette drive by:

- Reporting the problem to your vendor
- Reporting the problem to the Digital Customer Help Line

800-DEC-8000

- Ordering the part and installing it yourself if you have the *Rainbow™ 100 User's Service Guide*. (The part number for this guide is EK-P100E-SV.)

Drive A (or B as appropriate) – Message 5

This message displays when you run the extended selftest program if the diskette in the drive is not formatted. Insert another diskette into the drive; then, run the selftest program again.

If the problem persists after trying several diskettes, make sure that the diskette drive cables are installed properly. If the problem still persists, replace the drive by:

- Reporting the problem to your vendor
- Reporting the problem to the Digital Customer Help Line

800-DEC-8000

- Ordering the part and installing it yourself if you have the *Rainbow™ 100 User's Service Guide*. (The part number for this guide is EK-P100E-SV.)

Drive A (or B as appropriate) – Message 12

This message displays when you run the selftest program if any of the following occur.

- There is no diskette in the specified drive. To correct the problem, insert a diskette into the drive.
- The diskette is upside-down in the drive. To correct the problem, insert the diskette correctly into the drive.
- The drive door is not closed. To correct the problem, close the drive door.

Run the selftest program again after correcting the problem. If the problem persists, make sure that the diskette drive cables are installed correctly. If the problem still persists, replace the diskette drive by:

- Reporting the problem to your vendor
- Reporting the problem to the Digital Customer Help Line
800-DEC-8000
- Ordering the part and installing it yourself if you have the *Rainbow™ 100 User's Service Guide*. (The part number for this guide is EK-P100E-SV.)

Drive Not Ready – Message 21

This message displays when you start the operating system if any of the following occur.

- There is no diskette in the specified drive. To correct the problem, insert a diskette into the specified drive.
- The diskette is upside-down in the drive. To correct the problem, insert the diskette correctly into the drive.
- Drive C, D, or W is specified on a computer with drives A and B only. To correct the problem, specify drive A or B.
- The drive door is not closed. To correct the problem, close the drive door.

Start the operating system again after correcting the problem. If the problem persists, make sure that the drive is installed correctly. If the error still persists, replace the drive by:

- Reporting the problem to your vendor
- Reporting the problem to the Digital Customer Help Line
800-DEC-8000
- Ordering the part and installing it yourself if you have the *Rainbow™ 100 User's Service Guide*. (The part number for this guide is EK-P100E-SV.)

Interrupts Off – Message 16

The system displays this message when you turn on the Rainbow computer or while you run an application program.

The system displays this message in three ways.

1. When the system displays the message alone on the screen, you cannot use the Rainbow computer as a personal computer or as a terminal until the problem is corrected. Turn the computer off and then on again. If the error persists after several retries, replace the system module by:
 - Reporting the problem to your vendor
 - Reporting the problem to the Digital Customer Help Line
800-DEC-8000
 - Ordering the part and installing it yourself if you have the *Rainbow™ 100 User's Service Guide*. (The part number for this guide is EK-P100E-SV.)
2. If the system displays the message above the Main System Menu, you can use the Rainbow computer as a personal computer and as a terminal. Turn the computer off and then on again. If the problem persists, you should call your vendor or the Digital Customer Help Line for assistance.
3. If the system displays the message while running an application program, you should remove the application program diskette from the drive and then turn the computer off and then on again.

If the system does not display the problem message when you turn the computer on, rerun the application program. If the problem message displays while rerunning the program, report the problem to the vendor who sold you the application program or, if you wrote the program, check the program for an interrupts off instruction.

Keyboard – Message 13

The system displays this message when you turn on the Rainbow computer if the keyboard is not connected, a key is depressed, or the keyboard is not working correctly. You cannot use the Rainbow computer as a personal computer or a terminal if this message displays until you correct the problem. To correct the problem:

- Make sure you do not press any keys while the computer is going through power-up or reset
- Make sure that the keyboard cable is secured to the back of the monitor and to the bottom of the keyboard
- Check for any keys that may be stuck by running your fingers over the top of the keyboard keys
- Make sure the video cable is securely connected.

Now, turn the computer off and on again. If the problem persists after several retries, replace the keyboard by:

- Reporting the problem to your vendor
- Reporting the problem to the Digital Customer Help Line
800-DEC-8000
- Ordering the part and installing it yourself if you have the *Rainbow™ 100 User's Service Guide*. (The part number for this guide is EK-P100E-SV.)

Main Board – Messages 1, 2, 10, 17, 18, 19, 20, 26, 30, 31, 33, 50

These messages display when you turn on the Rainbow computer. You cannot use the Rainbow computer as a personal computer or a terminal until you correct the problem.

Turn the computer off and then on again. If the problem persists after several retries, replace the system module by:

- Reporting the problem to your vendor
- Reporting the problem to the Digital Customer Help Line
800-DEC-8000
- Ordering the part and installing it yourself if you have the *Rainbow™ 100 User's Service Guide*. (The part number for this guide is EK-P100E-SV.)

Main Board – Message 14

This message displays when you turn on the Rainbow computer if your previous Set-Up selections, such as screen background and number of columns, were not read correctly. You can still use the Rainbow computer as a personal computer or a terminal; however, Set-Up selections that you previously saved are not in effect.

Review your Set-Up selections, recall the default settings by pressing **(Shift/D)**, and save them by pressing **(Shift/S)**. Turn the computer off and then on again. If the problem persists after several retries, replace the system module by:

- Reporting the problem to your vendor
- Reporting the problem to the Digital Customer Help Line
800-DEC-8000
- Ordering the part and installing it yourself if you have the *Rainbow™ 100 User's Service Guide*. (The part number for this guide is EK-P100E-SV.)

Main Board – Message 29

This message displays when you turn on the Rainbow computer or when you start the operating system. Turn the computer off, then on again. Make sure you are not using a VT180 operating system diskette. To correct the problem, insert another Rainbow operating system diskette into the drive and start the operating system again.

If the problem persists after several retries, replace the system module by:

- Reporting the problem to your vendor
- Reporting the problem to the Digital Customer Help Line
800-DEC-8000
- Ordering the part and installing it yourself if you have the *Rainbow™ 100 User's Service Guide*. (The part number for this guide is EK-P100E-SV.)

Main Board – Message 40

This message displays when you turn on the Rainbow computer if the printer connector (PRINTER) is not working properly. You cannot use a printer if this message displays; however, you can still use the Rainbow computer as a personal computer or terminal.

Turn the computer off and then on again. If the problem persists after several retries, replace the system module if you want to use a printer. To replace the system module:

- Report the problem to your vendor
- Report the problem to the Digital Customer Help Line
800-DEC-8000
- Order the part and install it yourself if you have the *Rainbow™ 100 User's Service Guide*. (The part number for this guide is EK-P100E-SV.)

Main Board – Message 60

This message displays when you turn on the Rainbow computer if the communications connector (COMM) is not working properly. You cannot use the Rainbow computer as a terminal when this message displays; however, you can use the Rainbow computer as a personal computer if the communications connector is not used.

Turn the computer off and then on again. If the problem persists after several retries, replace the system module by:

- Reporting the problem to your vendor
- Reporting the problem to the Digital Customer Help Line
800-DEC-8000
- Ordering the part and installing it yourself if you have the *Rainbow™ 100 User's Service Guide*. (The part number for this guide is EK-P100E-SV.)

If you want to use the computer as a personal computer, insert a system diskette into a drive and start the operating system.

Memory Board – Message 27

This message displays when you run the extended selftest program and it finds a problem in the optional memory board. You can use the computer as a personal computer or a terminal; however, if you use it as a personal computer, you may encounter problems running programs.

Turn the computer off and then on again. If the problem persists after several retries, replace the optional memory board by:

- Reporting the problem to your vendor
- Reporting the problem to the Digital Customer Help Line
800-DEC-8000
- Ordering the part and installing it yourself if you have the *Rainbow™ Memory Test Guide* (EK-RBMZE-IN-CN1).

New Memory Size = nnnK – Message 24

If you have just installed or removed additional memory, this message displays once when you first turn on the Rainbow computer. Confirm that you now have the correct amount of memory. If the message displays and you have not installed or removed memory, check to see that the memory board is not loose.

If the message persists:

- Report the problem to your vendor
- Report the problem to the Digital Customer Help Line

800-DEC-8000

- Order the part and install it yourself if you have the *Rainbow™ Memory Board Option Installation Guide* (EK-RBMXE-IN).

Non-System Diskette – Message 23

This message displays when you start the operating system if the diskette in the drive is not the system diskette. To correct the problem, insert a system diskette into a drive and start the operating system again.

Remove Card or Diskette – Message 22

This message displays when you turn on the Rainbow computer if:

- The protective card is in the drive and the drive door is closed. To correct the problem, remove the protective card.
- The diskette is upside-down or inserted incorrectly in the drive and the drive door is closed. To correct the problem, remove the diskette, turn the computer off and then on again, and insert the diskette correctly.

RX50 Controller Board – Message 28

This message displays when you turn on the Rainbow computer. You cannot use the Rainbow computer as a personal computer until you correct the problem. However, you can use it as a terminal.

If you want to use the Rainbow computer as a personal computer, turn the computer off and then on again. If the problem persists after several retries, remove the RX50 controller board and insert it again (it may have loosened from the system module). Refer to the *Rainbow™ 100 User's Service Guide* for instructions. If the problem still persists, replace the RX50 controller board by:

- Reporting the problem to your vendor
- Reporting the problem to the Digital Customer Help Line

800-DEC-8000

- Ordering the part and installing it yourself if you have the *Rainbow™ 100 User's Service Guide*. (The part number for this guide is EK-P100E-SV.)

Set-Up Defaults Stored – Message 25

This message displays when you turn on the Rainbow computer. It informs you that a problem was found and corrected in the part of the computer that saves your Set-Up selections. If you receive this message, you are at the Language Selection Menu. The Set-Up selections that you have previously saved are not in effect; the default Set-Up selections (those set at the factory) are in effect. You can use the Rainbow computer as a personal computer or a terminal; the message is informative only. Reset and save your desired Set-Up selections.

System Load Incomplete – Messages 9, 11

These messages display when you start the operating system if any of the following occur.

- The diskette is write-protected and is upside-down in the drive. To correct, insert the diskette correctly in the drive.
- The diskette in the drive is not a Rainbow operating system diskette. To correct, insert a Rainbow operating system diskette in the drive.
- The operating system program on the diskette is unreadable or is not inserted fully in the drive. Use another diskette.

Now, restart the operating system. If the problem persists, insert another operating system diskette into the drive and start again.

Diskette Diagnostic Test Messages

Table B-2 lists the Rainbow diskette diagnostic test messages that can occur while running the Rainbow diskette diagnostic test.

Table B-2. Diskette Diagnostic Test Messages

Messages	Possible Source/ Corrective Action
Diagnostic Executive Messages	
SYSTEM ERROR: COMPUTER CANNOT FIND SUFFICIENT MEMORY	Diagnostic diskette or system module. Try another diskette. Replace system module.
SYSTEM ERROR: DISK READ OR WRITE FAILED RESTART SYSTEM	Diagnostic diskette, diskette drive, or system module. Try another diskette. Replace system module.
SYSTEM ERROR: COMPUTER CANNOT READ TEST FILE FROM THE DISK	Diagnostic diskette. Try another diskette.
SYSTEM ERROR: COMPUTER CANNOT READ MESSAGE FILE FROM THE DISK	Diagnostic diskette. Try another diskette.
SYSTEM ERROR: COMPUTER NOT RUNNING CORRECTLY	
Set-Up Memory Tests Messages	
FAILURE: MAIN BOARD SET-UP MEMORY DOES NOT STORE DATA CORRECTLY	Make sure memory is installed correctly.
FAILURE: MAIN BOARD: MEMORY STORES DATA INCORRECTLY	System module. Replace system module.
FAILURE: MAIN BOARD: CANNOT COPY SET-UP MEMORY	
FAILURE: MEMORY OPTION BOARD: MEMORY STORES DATA INCORRECTLY	Memory option board. Replace memory.

Table B-2. Diskette Diagnostic Test Messages (Cont)

Messages	Possible Source/ Corrective Action
RAM Test Messages	
FAILURE: MAIN BOARD: INVALID SET-UP DATA FOR OPTIONAL MEMORY	System module. Replace system module.
ERROR: OPTION MEMORY BOARD PRESENT; SET-UP SHOWS IT IS NOT PRESENT	Memory size is incorrect. Make sure the memory board is installed correctly.
ERROR: OPTION MEMORY BOARD NOT PRESENT; SET-UP SHOWS IT PRESENT	Memory size is incorrect. Make sure the memory board is installed correctly.
SYSTEM ERROR: COMPUTER CANNOT FIND SUFFICIENT MEMORY	System module. Replace system module.
SYSTEM ERROR: SYSTEM CLOCK DOES NOT WORK	System module. Replace system module.
ERROR: SET-UP FOR MEMORY SIZE IS NOT CORRECT	Memory size is incorrect. Make sure the memory board is installed correctly.
FAILURE: MEMORY OPTION BOARD: PARITY DETECTION DOES NOT WORK : OPTION MEMORY: MEMORY SIZE IS INCORRECT : OPTION MEMORY: OPTION MEMORY SIGNAL IS INCORRECT	Replace memory board.
TEST CANNOT CONTINUE – PLEASE RESTART SYSTEM	Diagnostic diskette.
RAM Arbitration Test Messages	
FAILURE: MAIN BOARD: MEMORY STORES DATA INCORRECTLY	System module. Replace system module.
SYSTEM ERROR: SYSTEM CANNOT FIND SUFFICIENT MEMORY	System module. Replace system module.
SYSTEM ERROR: TEST PROGRAM DOES NOT FUNCTION CORRECTLY	Diagnostic diskette.

Table B-2. Diskette Diagnostic Test Messages (Cont)

Messages	Possible Source/ Corrective Action
Diskette Drive Error Messages	
FAILURE: MAIN BOARD: ILLEGAL INTERRUPT TO Z80	Repeat test; if error persists, replace system module.
Z80 DIAGNOSTIC FILE NOT FOUND	Cannot find file on diskette.
FAILURE: MAIN BOARD: Z80 RESPONSE FAILURE	Repeat test; if message persists, replace system module.
SYSTEM ERROR: INSUFFICIENT MEMORY FOR DIAGNOSTICS	Repeat test; if message persists, replace system module.
FAILURE: RX50 CONTROLLER BOARD: INTERNAL REGISTER HEAD LOAD TIMING LOOP BACK READ RESTORE MOTOR SHUT OFF FORCED SEEK SEEK FAILURE (with no verify) FORCED RECORD NOT FOUND (read) FORCED LOST DATA (read) NO TRACK GREATER THAN 43 SIGNAL FORCED RECORD NOT FOUND (write) FORCED LOST DATA (write) WRITE SECTOR	Bad connection between system module and RX50 controller module; remove and reseal controller module. Run test again; if message persists, replace RX50 controller module.
FAILURE: RX50 CONTROLLER BOARD: WRITE SECTOR	Could be a bad diskette; try another diskette and run test again. If message persists, remove and reseal RX50 controller module; if error still persists, replace RX50 controller module.
FAILURE: DRIVE X (where X = A, B, C, or D) – DRIVE NOT READY	Diskette is not inserted properly or is upside-down; diskette drive door is open.
INDEX PULSE	Diskette may be upside-down or is not spinning.

Table B-2. Diskette Diagnostic Test Messages (Cont)

Messages	Possible Source/ Corrective Action
SEEK (with verify)	Could be a bad diskette; rerun test using another diskette.
READ SECTOR	May occur after a write sector failure. Could be a bad diskette; try another diskette.
WRITE SECTOR	Could be a bad diskette; try another diskette.
DISKETTE WRITE-PROTECTED	Write-protect tab is on diskette.
<p>NOTE The following diskette drive error messages may occur from poor connection between the RX50 controller module and the diskette drive. Reseat cables and rerun tests. If any of these errors persist, remove and replace the diskette drive.</p>	
FAILURE:DRIVE X (where X = A, B, C, or D) – RESTORE	No track 0 signal coming from drive; try again; replace diskette drive.
STEP	Head did not move in correct amount of time; try again; replace diskette drive.
MOTOR SPEED	Diskette drive motor is turning too fast or too slow; diskette may be warped, try another; replace diskette drive.
STEP-IN	Head did not move toward spindle correctly; replace diskette drive.
STEP-OUT	Head did not move away from spindle correctly; replace diskette drive.

Table B-2. Diskette Diagnostic Test Messages (Cont)

Messages	Possible Source/ Corrective Action
MULTI-TRACK TIMING	Head did not move away from spindle correctly; replace diskette drive.
Z80 Private RAM Test Error Messages	
SYSTEM ERROR: CANNOT LOAD Z80 TEST PROGRAM FROM DISKETTE	Diagnostic diskette.
SYSTEM ERROR: TEST DOES NOT FUNCTION CORRECTLY	Diagnostic diskette or system module.
FAILURE: MAIN BOARD: Z80 FAILED TO START MEMORY TEST	System module. Replace system module.
FAILURE: MAIN BOARD: Z80 FAILED TO COMPLETE MEMORY TEST	System module. Replace system module.
FAILURE: MAIN BOARD: Z80 PRIVATE MEMORY DOES NOT STORE DATA CORRECTLY	System module. Replace system module.
FAILURE: MAIN BOARD: Z80 CANNOT COPY DATA TO SHARED (Z80/8088) MEMORY	System module. Replace system module.
FAILURE: MAIN BOARD: Z80 CANNOT RESTORE DATA TO Z80 PRIVATE MEMORY – TEST CANNOT CONTINUE, PLEASE RESTART SYSTEM –	Reboot system and try again; if problem persists, replace system module.
FAILURE: MAIN BOARD: Z80 DID NOT EXECUTE THE TEST CORRECTLY	Diagnostic diskette or system module.
System Interaction Error Messages	
FAILURE: MAIN BOARD: I/O ERROR COMM CHANNEL (A) ERROR PRINTER KEYBOARD PORT ERROR DISKETTE WRITE ERROR SYSTEM ERROR	
Z80 DIAGNOSTIC FILE NOT FOUND	
FAILURE: DRIVE B: WRITE ERROR	
FAILURE: DISKETTE WRITE-PROTECTED	

Table B-2. Diskette Diagnostic Test Messages (Cont)

Messages	Possible Source/ Corrective Action
Video Controller Test Error Messages	
FAILURE: MAIN BOARD: VIDEO ERROR VERTICAL RETRACE RATE	The vertical retrace rate is either too fast or too slow. Replace the system module.
FAILURE: MAIN BOARD: VIDEO ERROR A LOOPBACK CHECK IS INCORRECT	The information sent to the video output is being altered. Replace the system module.
Keyboard Test	
SYSTEM ERROR: KEY PROCESSING	Replace system module.

C

Rainbow Parts List and Reference Manuals

Rainbow Parts List

Table C-1 lists the field-upgradeable parts of the Rainbow computer and their part numbers. For a more detailed parts list and description, refer to the *Rainbow™ 100 System Unit Illustrated Parts Breakdown*, EK-SB100-IP.

Reference Manuals

Table C-2 lists reference manuals that may be helpful to you.

Ordering Information

You may purchase parts or manuals by contacting:

Digital Equipment Corporation
Accessories and Supplies Group
P.O. Box CS2008
Nashua, New Hampshire 03061

Table C-1. Rainbow Parts List

Part	Digital Part Number
System module	70-19974-02
64K byte memory board option	PC1XX-AC
256K byte memory board option	PC1XX-AD
64K byte memory component kit (9 chips)	PC1XX-AY
256K byte memory component kit (9 chips)	PC1XX-AZ
Power supply	H7842-D
RD51 hard disk drive	RCD51-A
Hard disk controller board	54-16019
RX50 dual-diskette drive	RX50-AA
RX50 controller module	54-15482
RX50 diskettes (pack of 10)	RX50K-10
Keyboard, U.S.	LK201-AA
Keyboard label strip, U.S.	36-20220-12
Video monitor assembly (white phosphor)	VR201-AA
Cable, power supply to system module, 10.1 cm (4 in)	17-00318-02
Cable, RX50 shielded, 20.3 cm (8 in)	17-00317-03
Cable, RX50 shielded, 36.8 cm (14.5 in)	17-00317-04
Line cord, 115 Vac, U.S.	17-00083-09
Cable, keyboard	BCC01
Cable, monitor 1.8 m (6 ft)	17-00283-00
Cable, communications/printer, 3 m (10 ft)	BCC04-10
Cable, communications/printer, 7.6 m (25 ft)	BCC04-25

Table C-1. Rainbow Parts List (Cont)

Part	Digital Part Number
Cable, communications/printer, 15.3 m (50 ft)	BCC04-50
Standoff, module	12-19857-01
Standoff, hard disk controller	74-29164-01
COMM connector loopback plug	12-15336-01
EXT COMM connector loopback plug	12-15366-04
PRINTER connector loopback plug	29-24631-00
Color monitor	VR241-A
Cable, color monitor	BCC17
Color/graphics option board	54-15688
Cable, hard disk drive	17-00427-01
Cable, modem	BCC15
Extended communications option board	54-15703-00
Fan bracket assembly	70-20816-01
Filler panel, PC100	74-27174-01

Table C-2. Reference Manuals

Title	Digital Part Number
Rainbow™ Installation Guide	EK-R100E-IN
Rainbow™ 100 User's Service Guide	EK-P100E-SV
Rainbow™ 100 System Unit Illustrated Parts Breakdown	EK-SB100-IP
Rainbow™ Pocket Service Guide	EK-PC100-PS
Rainbow™ Memory Board Option Installation Guide	EK-RBMXE-IN
Rainbow™ Winchester Disk Option Installation Guide	EK-RBWIN-IN
Rainbow™ Extended Communications Option Installation Guide	EK-PCEXC-IN
Rainbow™ Color/Graphics Option Installation Guide	EK-PCCOL-IN
VR241A Installation Guide (color monitor)	EK-VR241-IN

Contact your local Digital sales office or call Digital's Direct Catalog Sales toll-free (800) 258-1710 from 8:30 a.m. to 5:00 p.m. eastern standard time (U.S. customers only). In New Hampshire, Alaska, and Hawaii call (603) 884-6660.

Terms and conditions include net 30 days and FOB from the Digital shipping point. Freight charges are prepaid by Digital and added to the invoice. (Orders placed against an open line of credit require the customer to pay the shipment charge.)

Shipment charges for all cash orders (that is, payment by check, MasterCard™, Visa®, or American Express®) are paid by Digital for shipment within the continental United States.

The payment of state and local taxes, duties, and levies is the responsibility of the buyer.

The minimum order is \$35.00, but this minimum does not apply when full payment is sent with the order. Make checks and money orders payable to *Digital Equipment Corporation*.

D

International Language Keyboards

The figures in this appendix illustrate the 15 different Rainbow national language keyboards that are available and the keys on each. One of the main differences is the label strip that you add to the top of the keyboard. The label strip comes with the documentation shipped with the system.

All keyboards except the American/Canadian keyboard have one or more keys that display different characters, depending on whether the keyboard is in correspondence mode or data processing (DP) mode. You switch from one mode to the other in Set-Up. In the illustrations that follow, keys that differ depending on the mode are shown in color. The character(s) on the right side of the key are displayed in DP mode.

All the keyboards except the American/Canadian keyboard allow some two-key compose sequences. For example, to display é on a Danish keyboard, press ' , then you type e. Keys to start a two-key compose sequence are shown in gray. See Chapter 2, The Rainbow Keyboard, for a description of the two-key compose sequence. If you make a mistake, your keyboard will beep (if the keyboard bell is set to on).

Figure D-3. LK201-AC Canadian (French) keyboard

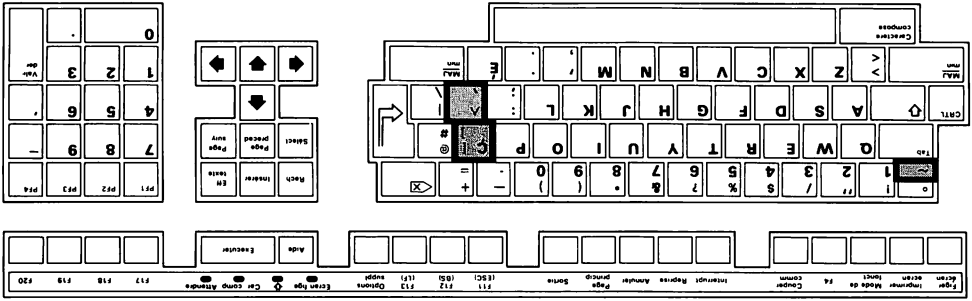

Figure D-2. LK201-AB Belgian/Flemish keyboard

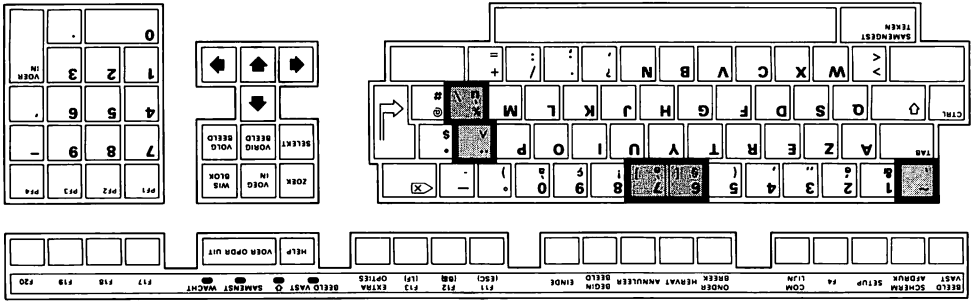

Figure D-1. LK201-AA American (English) keyboard

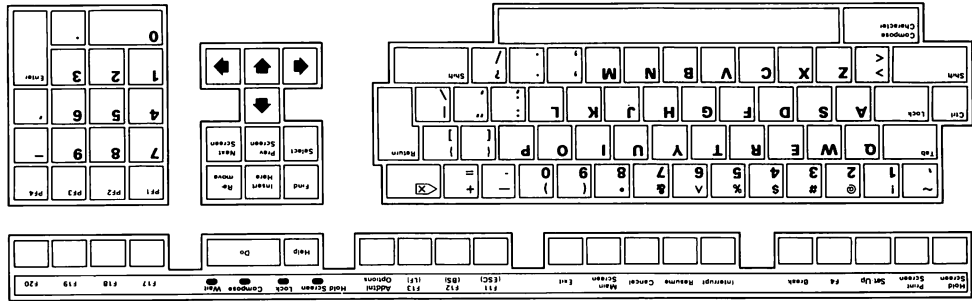

Figure D-6. LK201-AF Finnish keyboard

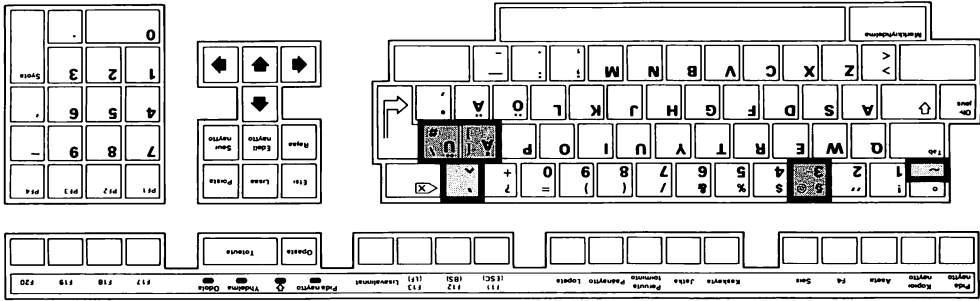

Figure D-5. LK201-AE British keyboard

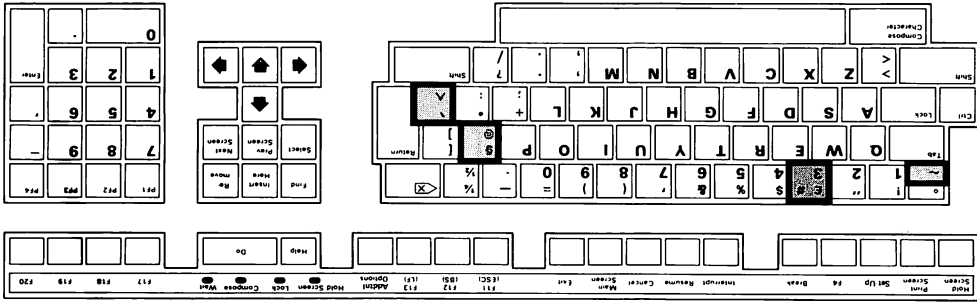

Figure D-4. LK201-AD Danish keyboard

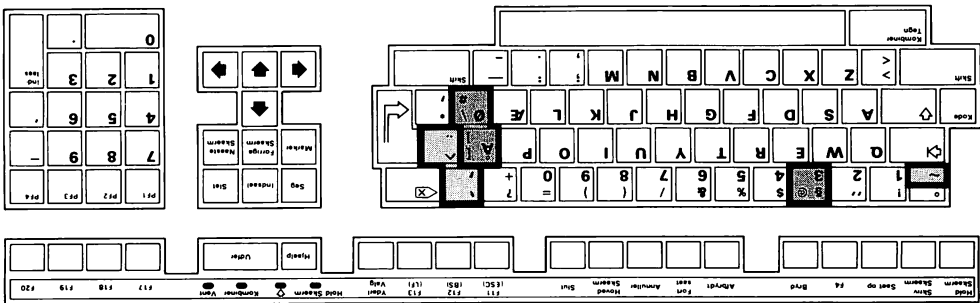

Figure D-9. LK201-AI Italian keyboard

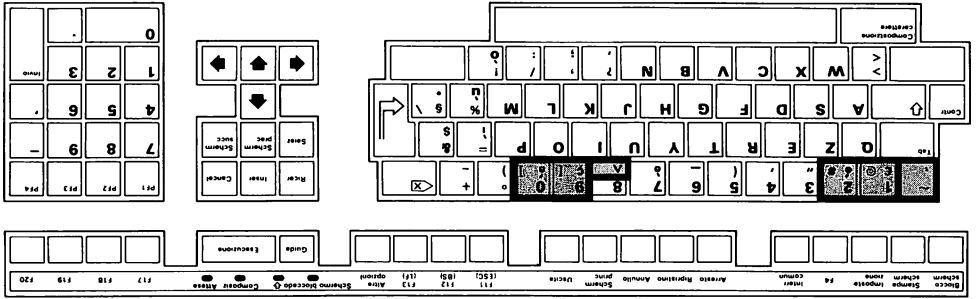

Figure D-8. LK201-AH Dutch keyboard

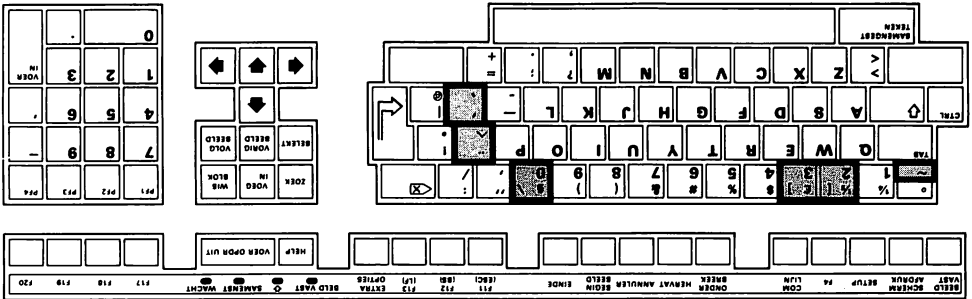

Figure D-7. LK201-AG Austrian/German keyboard

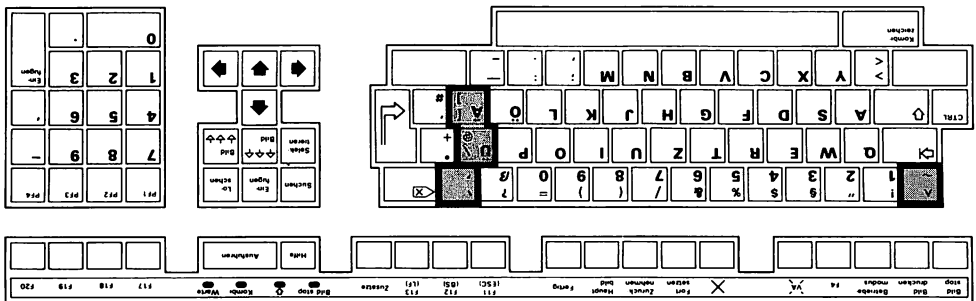

Figure D-12. LK201-AM Swedish keyboard

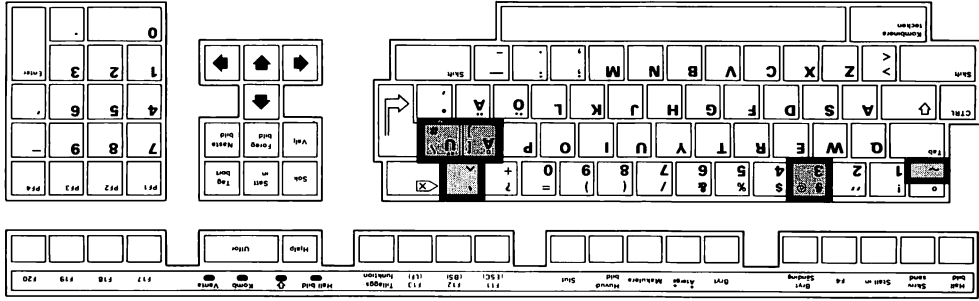

Figure D-11. LK201-AL Swiss (German) keyboard

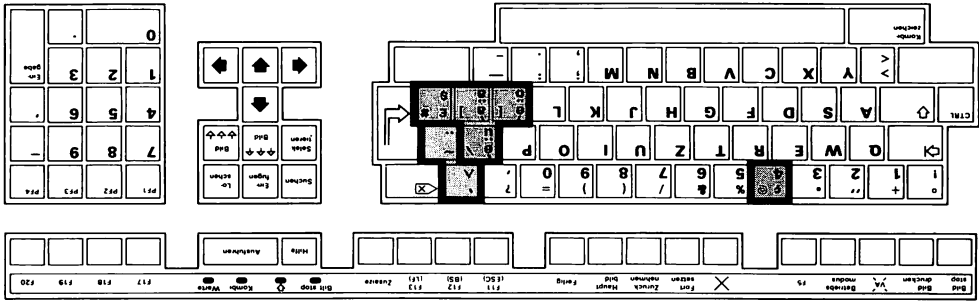
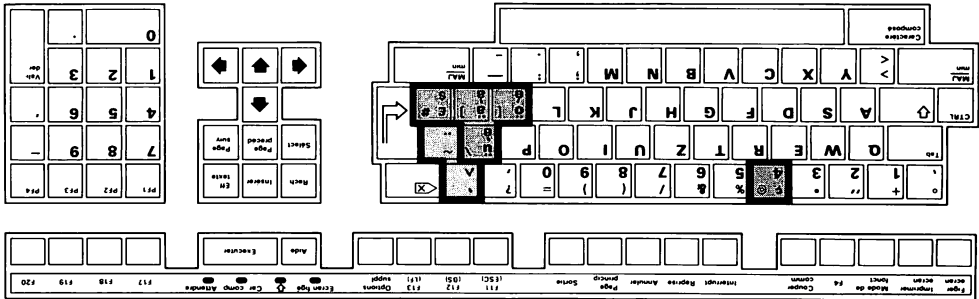

Figure D-10. LK201-AK Swiss (French) keyboard



F

7-bit/DEC 8-bit Translations

The following figures show the 7-bit and 8-bit translations and character sets for each language keyboard.

KEYBOARD	7-bit NRC TABLE USED
American	(none)
Belgian/Flemish	French
Canadian (French)	French Canadian
Danish	Norwegian /Danish
British	United Kingdom
Finnish	Finnish
Austrian/German	German
Dutch	Dutch
Italian	Italian
Swiss (French)	Swiss
Swiss (German)	Swiss
Swedish	Swedish
Norwegian	Norwegian/Danish
Belgian/French	French
Spanish	Spanish

Figure F-1. Mapping Keyboard to National Replacement Characters

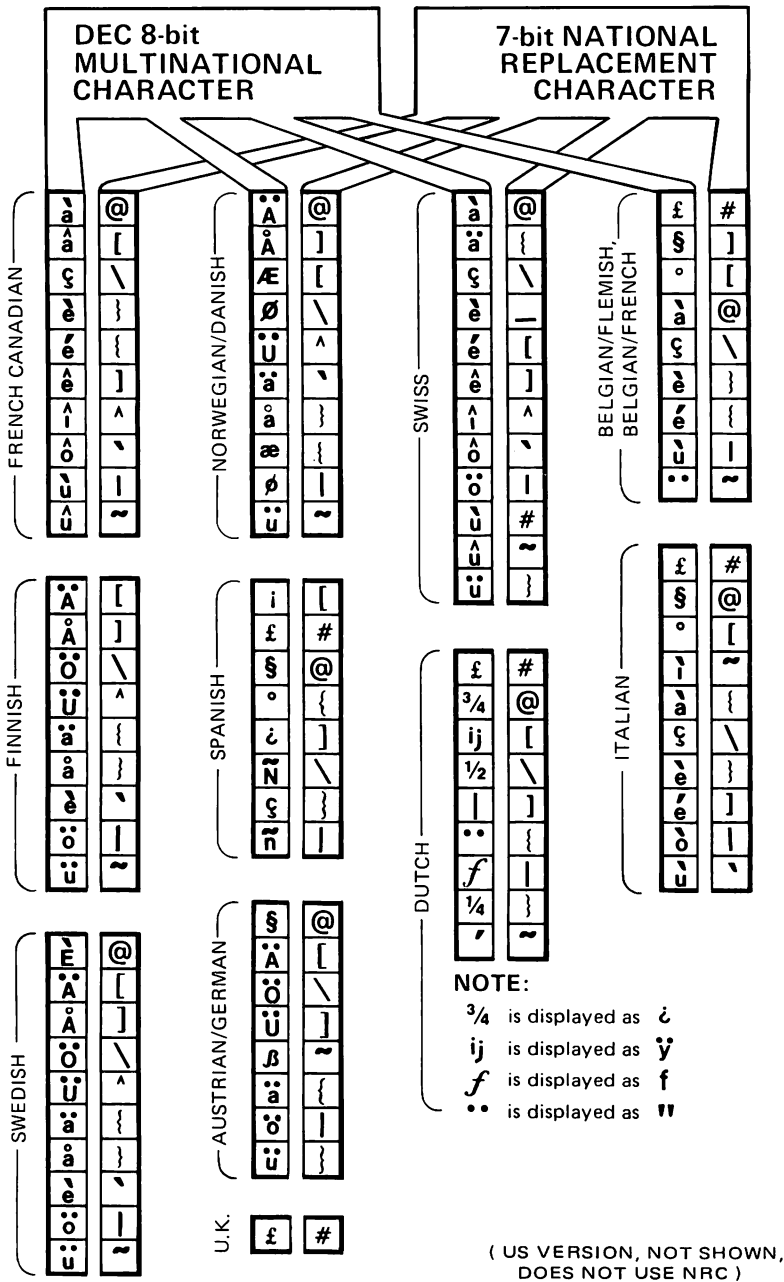

Figure F-2. 7-bit/DEC 8-bit Translations

COL USER		0		1		2		3		4		5		6		7		8		9		A		B		C		D		E		F		
ROW																																		
0	NUL	DLE	SP	0	@	P	\	p	DCS	240	240	240	240	240	240	240	240	240	240	240	240	240	240	240	240	240	240	240	240	240	240	240	240	
1	SOH	DC1	!	1	A	Q	a	q	PU1	221	241	241	241	241	241	241	241	241	241	241	241	241	241	241	241	241	241	241	241	241	241	241	241	241
2	STX	DC2	"	2	B	R	b	r	PU2	222	242	242	242	242	242	242	242	242	242	242	242	242	242	242	242	242	242	242	242	242	242	242	242	242
3	ETX	DC3	#	3	C	S	c	s	STS	223	243	243	243	243	243	243	243	243	243	243	243	243	243	243	243	243	243	243	243	243	243	243	243	243
4	EOT	DC4	\$	4	D	T	d	t	IND	204	244	244	244	244	244	244	244	244	244	244	244	244	244	244	244	244	244	244	244	244	244	244	244	244
5	ENQ	NAK	%	5	E	U	e	u	NEL	205	245	245	245	245	245	245	245	245	245	245	245	245	245	245	245	245	245	245	245	245	245	245	245	245
6	ACK	SYN	&	6	F	V	f	v	SSA	206	246	246	246	246	246	246	246	246	246	246	246	246	246	246	246	246	246	246	246	246	246	246	246	246
7	BEL	ETB	'	7	G	W	g	w	ESA	207	247	247	247	247	247	247	247	247	247	247	247	247	247	247	247	247	247	247	247	247	247	247	247	247
8	BS	CAN	(8	H	X	h	x	HTS	210	250	250	250	250	250	250	250	250	250	250	250	250	250	250	250	250	250	250	250	250	250	250	250	250
9	HT	EM)	9	I	Y	i	y	HTJ	211	251	251	251	251	251	251	251	251	251	251	251	251	251	251	251	251	251	251	251	251	251	251	251	251
A	LF	SUB	*		J	Z	j	z	VTS	212	252	252	252	252	252	252	252	252	252	252	252	252	252	252	252	252	252	252	252	252	252	252	252	252
B	VT	ESC	+		K	[k	{	PLD	213	253	253	253	253	253	253	253	253	253	253	253	253	253	253	253	253	253	253	253	253	253	253	253	253
C	FF	FS	,		L	\	l		PLU	214	254	254	254	254	254	254	254	254	254	254	254	254	254	254	254	254	254	254	254	254	254	254	254	254
D	CR	GS	-		M]	m	}	RI	215	255	255	255	255	255	255	255	255	255	255	255	255	255	255	255	255	255	255	255	255	255	255	255	255
E	SO	RS	.		N	^	n	~	SS2	216	256	256	256	256	256	256	256	256	256	256	256	256	256	256	256	256	256	256	256	256	256	256	256	256
F	SI	US	/		O	_	o	DEL	SS3	217	257	257	257	257	257	257	257	257	257	257	257	257	257	257	257	257	257	257	257	257	257	257	257	257

Figure F-3. DEC Multinational Character Set (DEC 8-bit)

NOTE

Empty positions are reserved for future use.

7-bit/DEC 8-bit Translations

BITS B7 B6 B5 B4 B3 B2 B1		0 0		0 0 1		0 1 0		0 1 1		1 0 0		1 0 1		1 1 0		1 1 1	
		COLUMN		1		2		3		4		5		6		7	
ROW		0		1		2		3		4		5		6		7	
0 0 0 0	0	NUL	0 0 0		20 16 10	SP	40 32 20	0	60 48 30		100 64 40	P	120 80 50	,	140 96 60	p	160 112 70
0 0 0 1	1		1 1 1	DC1 (XON)	21 17 11	!	41 33 21	1	61 49 31	A	101 65 41	Q	121 81 51	a	141 97 61	q	161 113 71
0 0 1 0	2		2 2 2		22 18 12	"	42 34 22	2	62 50 32	B	102 66 42	R	122 82 52	b	142 98 62	r	162 114 72
0 0 1 1	3		3 3 3	DC3 (XOFF)	23 19 13	£	43 35 23	3	63 51 33	C	103 67 43	S	123 83 53	c	143 99 63	s	163 115 73
0 1 0 0	4		4 4 4		24 20 14	\$	44 36 24	4	64 52 34	D	104 68 44	T	124 84 54	d	144 100 64	t	164 116 74
0 1 0 1	5		5 5 5		25 21 15	%	45 37 25	5	65 53 35	E	105 69 45	U	125 85 55	e	145 101 65	u	165 117 75
0 1 1 0	6		6 6 6		26 22 16	&	46 38 26	6	66 54 36	F	106 70 46	V	126 86 56	f	146 102 66	v	166 118 76
0 1 1 1	7		7 7 7		27 23 17	'	47 39 27	7	67 55 37	G	107 71 47	W	127 87 57	g	147 103 67	w	167 119 77
1 0 0 0	8	BS	10 8 8	CAN	30 24 18	(50 40 28	8	70 56 38	H	110 72 48	X	130 88 58	h	150 104 68	x	170 120 78
1 0 0 1	9	HT	11 9 9		31 25 19)	51 41 29	9	71 57 39	I	111 73 49	Y	131 89 59	i	151 105 69	y	171 121 79
1 0 1 0	10	LF	12 10 A	SUB	32 26 1A	*	52 42 2A	:	72 58 3A	J	112 74 4A	Z	132 90 5A	j	152 106 6A	z	172 122 7A
1 0 1 1	11	VT	13 11 B	ESC	33 27 1B	+	53 43 2B	;	73 59 3B	K	113 75 4B	ÿ	133 91 5B	k	153 107 6B	”	173 123 7B
1 1 0 0	12	FF	14 12 C		34 28 1C	,	54 44 2C	<	74 60 3C	L	114 76 4C	½	134 92 5C	l	154 108 6C	f	174 124 7C
1 1 0 1	13	CR	15 13 D		35 29 1D	-	55 45 2D	=	75 61 3D	M	115 77 4D		135 93 5D	m	155 109 6D	¼	175 125 7D
1 1 1 0	14	SO	16 14 E		36 30 1E	.	56 46 2E	>	76 62 3E	N	116 78 4E	^	136 94 5E	n	156 110 6E	'	176 126 7E
1 1 1 1	15	SI	17 15 F		37 31 1F	/	57 47 2F	?	77 63 3F	O	117 79 4F	_	137 95 5F	o	157 111 6F	DEL	177 127 7F

KEY

ASCII CHARACTER	ESC	33	OCTAL
		27	DECIMAL
		1B	HEX

Figure F-4. Dutch Character Set (7-bit)

NOTE

Empty positions are reserved for future use.

BITS		0 0 0		0 0 1		0 1 0		0 1 1		1 0 0		1 0 1		1 1 0		1 1 1			
B7 B6 B5		COLUMN		1		2		3		4		5		6		7			
B4	B3	B2	B1	0		1		2		3		4		5		6			
ROW				0		1		2		3		4		5		6			
0	0	0	0	0	NUL	0		20	SP	40	0	60	@	100	P	120	ä	140	p
0	0	0	1	1		1	DC1 (XON)	21	!	41	1	61	A	101	Q	121	a	141	q
0	0	1	0	2		2		22	"	42	2	62	B	102	R	122	b	142	r
0	0	1	1	3		3	DC3 (XOFF)	23	#	43	3	63	C	103	S	123	c	143	s
0	1	0	0	4		4		24	\$	44	4	64	D	104	T	124	d	144	t
0	1	0	1	5		5		25	%	45	5	65	E	105	U	125	e	145	u
0	1	1	0	6		6		26	&	46	6	66	F	106	V	126	f	146	v
0	1	1	1	7		7		27	'	47	7	67	G	107	W	127	g	147	w
1	0	0	0	8	BS	10	CAN	30	(50	8	70	H	110	X	130	h	150	x
1	0	0	1	9	HT	11		31)	51	9	71	I	111	Y	131	i	151	y
1	0	1	0	10	LF	12	SUB	32	*	52	:	72	J	112	Z	132	j	152	z
1	0	1	1	11	VT	13	ESC	33	+	53	;	73	K	113	Å	133	k	153	å
1	1	0	0	12	FF	14		34	,	54	<	74	L	114	Ö	134	l	154	ö
1	1	0	1	13	CR	15		35	-	55	=	75	M	115	Ä	135	m	155	ä
1	1	1	0	14	SO	16		36	.	56	>	76	N	116	Ü	136	n	156	ü
1	1	1	1	15	SI	17		37	/	57	?	77	O	117	—	137	o	157	DEL

KEY

ASCII CHARACTER  OCTAL 33
 DECIMAL 27
 HEX 1B

 HIGHLIGHTS DIFFERENCES FROM ASCII

Figure F-5. Finnish Character Set (7-bit)

NOTE
 Empty positions are reserved for future use.

7-bit/DEC 8-bit Translations

BITS				0 0		0 0 1		0 1 0		0 1 1		1 0 0		1 0 1		1 1 0		1 1 1		
B4 B3 B2 B1				COLUMN		1		2		3		4		5		6		7		
ROW				0		1		2		3		4		5		6		7		
0	0	0	0	0	NUL	0		20	SP	40	0	60	à	100	P	120	ô	140	p	160
0	0	0	1	1		0	DC1 (XON)	21	!	41	1	61	A	101	Q	121	a	141	q	161
0	0	1	0	2		2		22	"	42	2	62	B	102	R	122	b	142	r	162
0	0	1	1	3		3	DC3 (XOFF)	23	#	43	3	63	C	103	S	123	c	143	s	163
0	1	0	0	4		4		24	\$	44	4	64	D	104	T	124	d	144	t	164
0	1	0	1	5	ENQ	5		25	%	45	5	65	E	105	U	125	e	145	u	165
0	1	1	0	6		6		26	&	46	6	66	F	106	V	126	f	146	v	166
0	1	1	1	7	BEL	7		27	'	47	7	67	G	107	W	127	g	147	w	167
1	0	0	0	8	BS	8	CAN	30	(50	8	70	H	110	X	130	h	150	x	170
1	0	0	1	9	HT	9		31)	51	9	71	I	111	Y	131	i	151	y	171
1	0	1	0	10	LF	10	SUB	32	*	52	:	72	J	112	Z	132	j	152	z	172
1	0	1	1	11	VT	11	ESC	33	+	53	;	73	K	113	â	133	k	153	é	173
1	1	0	0	12	FF	12		34	,	54	<	74	L	114	ç	134	l	154	ù	174
1	1	0	1	13	CR	13		35	-	55	=	75	M	115	ê	135	m	155	è	175
1	1	1	0	14	SO	14		36	.	56	>	76	N	116	î	136	n	156	û	176
1	1	1	1	15	SI	15		37	/	57	?	77	O	117	—	137	o	157	DEL	177

KEY

ASCII CHARACTER



OCTAL
DECIMAL
HEX

Figure F-6. French Canadian Character Set (7-bit)

NOTE

Empty positions are reserved for future use.

BITS		COLUMN		1		2		3		4		5		6		7				
B7	B6	B5	0	0	0	0	0	0	1	1	1	1	1	1	1	1	1			
B4	B3	B2	B1	ROW	0	1	2	3	4	5	6	7	8	9	10	11	12			
0	0	0	0	0	NUL	0 0 0		20 16 10	SP	40 32 20	0	60 48 30	à	100 64 40	P	120 80 50	`	140 96 60	p	160 112 70
0	0	0	1	1		1 1 1	DC1 (XON)	21 17 11	!	41 33 21	1	61 49 31	A	101 65 41	Q	121 81 51	a	141 97 61	q	161 113 71
0	0	1	0	2		2 2 2		22 18 12	"	42 34 21	2	62 50 32	B	102 66 42	R	122 82 52	b	142 98 62	r	162 114 72
0	0	1	1	3		3 3 3	DC3 (XOFF)	23 19 13	£	43 35 23	3	63 51 33	C	103 67 43	S	123 83 53	c	143 99 63	s	163 115 73
0	1	0	0	4		4 4 4		24 20 14	\$	44 36 24	4	64 52 34	D	104 68 44	T	124 84 54	d	144 100 64	t	164 116 74
0	1	0	1	5	ENQ	5 5 5		25 21 15	%	45 37 25	5	65 53 35	E	105 69 45	U	125 85 55	e	145 101 65	u	165 117 75
0	1	1	0	6		6 6 6		26 22 16	&	46 38 26	6	66 54 36	F	106 70 46	V	126 86 56	f	146 102 66	v	166 118 76
0	1	1	1	7	BEL	7 7 7		27 23 17	'	47 39 27	7	67 55 37	G	107 71 47	W	127 87 57	g	147 103 67	w	167 119 77
1	0	0	0	8	BS	10 8 8	CAN	30 24 18	(50 40 28	8	70 56 38	H	110 72 48	X	130 88 58	h	150 104 68	x	170 120 78
1	0	0	1	9	HT	11 9 9		31 25 19)	51 41 29	9	71 57 39	I	111 73 49	Y	131 89 59	i	151 105 69	y	171 121 79
1	0	1	0	10	LF	12 10 A	SUB	32 26 1A	*	42 2A	:	72 58 3A	J	112 74 4A	Z	132 90 5A	j	152 106 6A	z	172 122 7A
1	0	1	1	11	VT	13 11 B	ESC	33 27 1B	+	53 43 2B	;	73 59 3B	K	113 75 4B	°	133 91 5B	k	153 107 6B	é	173 123 7B
1	1	0	0	12	FF	14 12 C		34 28 1C	,	54 44 2C	<	74 60 3C	L	114 76 4C	ç	134 92 5C	l	154 108 6C	ï	174 124 7C
1	1	0	1	13	CR	15 13 D		35 29 1D	-	55 45 2D	=	75 61 3D	M	115 77 4D	§	135 93 5D	m	155 109 6D	ù	175 125 7D
1	1	1	0	14	SO	16 14 E		36 30 1E	.	56 46 2E	>	76 62 3E	N	116 78 4E	^	136 94 5E	n	156 110 6E	è	176 126 7E
1	1	1	1	15	SI	17 15 F		37 31 1F	/	57 47 2F	?	77 63 3F	O	117 79 4F	—	137 95 5F	o	157 111 6F	DEL	177 127 7F

KEY

ASCII CHARACTER	ESC	33 27 1B	OCTAL DECIMAL HEX
-----------------	-----	----------------	-------------------------

Figure F-7. French Character Set (7-bit)

NOTE
Empty positions are reserved for future use.

7-bit/DEC 8-bit Translations

BITS		0 0		0 0 1		0 1 0		0 1 1		1 0 0		1 0 1		1 1 0		1 1 1								
B7 B6 B5 B4 B3 B2 B1		COLUMN		1		2		3		4		5		6		7								
ROW		0		1		2		3		4		5		6		7								
0	0	0	0	0	0	NUL	0	0	20	16	SP	40	32	0	60	48	§	100	P	120	'	140	P	160
0	0	0	0	1	1		1	1	21	17	!	41	33	1	61	49	A	101	Q	121	a	141	q	161
0	0	0	1	0	2		2	2	22	18	"	42	34	2	62	50	B	102	R	122	b	142	r	162
0	0	1	1	0	3		3	3	23	19	#	43	35	3	63	51	C	103	S	123	c	143	s	163
0	1	0	0	0	4		4	4	24	20	\$	44	36	4	64	52	D	104	T	124	d	144	t	164
0	1	0	1	0	5	ENQ	5	5	25	21	%	45	37	5	65	53	E	105	U	125	e	145	u	165
0	1	1	0	0	6		6	6	26	22	&	46	38	6	66	54	F	106	V	126	f	146	v	166
0	1	1	1	0	7	BEL	7	7	27	23	'	47	39	7	67	55	G	107	W	127	g	147	w	167
1	0	0	0	0	8	BS	8	8	28	24	(48	40	8	70	56	H	110	X	130	h	150	x	170
1	0	0	1	0	9	HT	9	9	29	25)	49	41	9	71	57	I	111	Y	131	i	151	y	171
1	0	1	0	0	10	LF	10	10	30	26	*	50	42	:	72	58	J	112	Z	132	j	152	z	172
1	0	1	1	0	11	VT	11	11	31	27	+	51	43	;	73	59	K	113	Ä	133	k	153	ä	173
1	1	0	0	0	12	FF	12	12	32	28	,	52	44	<	74	60	L	114	Ö	134	l	154	ö	174
1	1	0	1	0	13	CR	13	13	33	29	-	53	45	=	75	61	M	115	Ü	135	m	155	ü	175
1	1	1	0	0	14	SO	14	14	34	30	.	54	46	>	76	62	N	116	^	136	n	156	ß	176
1	1	1	1	0	15	SI	15	15	35	31	/	55	47	?	77	63	O	117	_	137	o	157	DEL	177

KEY

ASCII CHARACTER	ESC	33	OCTAL
		27	DECIMAL
		1B	HEX

Figure F-8. German Character Set (7-bit)

NOTE
Empty positions are reserved for future use.

BITS		COLUMN		1		2		3		4		5		6		7			
B7	B6	B5	0	0	0	0	0	1	1	1	1	1	1	1	1	1	1		
B4	B3	B2	B1	0	1	2	3	4	5	6	7	8	9	10	11	12	13		
ROW	0	1	2	3	4	5	6	7	8	9	10	11	12	13	14	15	16		
0	0	0	0	0	NUL	0	20	SP	40	0	60	§	100	P	120	ù	140	p	160
				0	0	0	16	32	32		48	64	80		80	96	112		
				0	0	0	10	20	20		30	40	50		50	60	70		
0	0	0	1	1		1	DC1 (XON)	!	41	1	61	A	Q	121	a	141	q	161	
				1	1	1	21	41	41		61	101	121		141	161			
				1	1	1	17	33	33		49	65	81		97	113			
				1	1	1	11	21	21		31	41	51		61	71			
0	0	1	0	2		2		"	42	2	62	B	R	122	b	142	r	162	
				2	2	2	22	42	42		62	102	122		142	162			
				2	2	2	18	34	34		50	66	82		98	114			
				2	2	2	12	22	22		32	42	52		62	72			
0	0	1	1	3		3	DC3 (XOFF)	£	43	3	63	C	S	123	c	143	s	163	
				3	3	3	23	43	43		63	103	123		143	163			
				3	3	3	19	35	35		51	67	83		99	115			
				3	3	3	13	23	23		33	43	53		63	73			
0	1	0	0	4		4		\$	44	4	64	D	T	124	d	144	t	164	
				4	4	4	24	44	44		64	104	124		144	164			
				4	4	4	20	36	36		52	68	84		100	116			
				4	4	4	14	24	24		34	44	54		64	74			
0	1	0	1	5	ENQ	5		%	45	5	65	E	U	125	e	145	u	165	
				5	5	5	25	45	45		65	105	125		145	165			
				5	5	5	21	37	37		53	69	85		101	117			
				5	5	5	15	25	25		35	45	55		65	75			
0	1	1	0	6		6		&	46	6	66	F	V	126	f	146	v	166	
				6	6	6	26	46	46		66	106	126		146	166			
				6	6	6	22	38	38		54	70	86		102	118			
				6	6	6	16	26	26		36	46	56		66	76			
0	1	1	1	7	BEL	7		'	47	7	67	G	W	127	g	147	w	167	
				7	7	7	27	47	47		67	107	127		147	167			
				7	7	7	23	39	39		55	71	87		103	119			
				7	7	7	17	27	27		37	47	57		67	77			
1	0	0	0	8	BS	10	CAN	(50	8	70	H	X	130	h	150	x	170	
				8	8	8	30	50	50		70	110	130		150	170			
				8	8	8	24	40	40		56	72	88		104	120			
				8	8	8	18	28	28		38	48	58		68	78			
1	0	0	1	9	HT	11)	51	9	71	I	Y	131	i	151	y	171	
				9	9	9	31	51	51		71	111	131		151	171			
				9	9	9	25	41	41		57	73	89		105	121			
				9	9	9	19	29	29		39	49	59		69	79			
1	0	1	0	10	LF	12	SUB	*	52	:	72	J	Z	132	j	152	z	172	
				10	10	10	32	52	52		72	112	132		152	172			
				10	10	10	26	42	42		58	74	90		106	122			
				10	10	10	1A	2A	2A		3A	4A	5A		6A	7A			
1	0	1	1	11	VT	13	ESC	+	53	;	73	K	o	133	k	153	à	173	
				11	11	11	33	53	53		73	113	133		153	173			
				11	11	11	27	43	43		59	75	91		107	123			
				11	11	11	1B	2B	2B		3B	4B	5B		6B	7B			
1	1	0	0	12	FF	14		,	54	<	74	L	ç	134	l	154	ò	174	
				12	12	12	34	54	54		74	114	134		154	174			
				12	12	12	28	44	44		60	76	92		108	124			
				12	12	12	1C	2C	2C		3C	4C	5C		6C	7C			
1	1	0	1	13	CR	15		-	55	=	75	M	é	135	m	155	è	175	
				13	13	13	35	55	55		75	115	135		155	175			
				13	13	13	29	45	45		61	77	93		109	125			
				13	13	13	1D	2D	2D		3D	4D	5D		6D	7D			
1	1	1	0	14	SO	16		.	56	>	76	N	^	136	n	156	ì	176	
				14	14	14	36	56	56		76	116	136		156	176			
				14	14	14	30	46	46		62	78	94		110	126			
				14	14	14	1E	2E	2E		3E	4E	5E		6E	7E			
1	1	1	1	15	SI	17		/	57	?	77	O	_	137	o	157	DEL	177	
				15	15	15	37	57	57		77	117	137		157	177			
				15	15	15	31	47	47		63	79	95		111	127			
				15	15	15	1F	2F	2F		3F	4F	5F		6F	7F			

KEY

ASCII CHARACTER

ESC	93
	27
	1B

OCTAL
DECIMAL
HEX

Figure F-9. Italian Character Set (7-bit)

NOTE

Empty positions are reserved for future use.

7-bit/DEC 8-bit Translations

BITS		0 0		0 0 1		0 1 0		0 1 1		1 0 0		1 0 1		1 1 0		1 1 1	
B7 B6 B5		0 0		0 0 1		0 1 0		0 1 1		1 0 0		1 0 1		1 1 0		1 1 1	
B4 B3 B2 B1		0		1		2		3		4		5		6		7	
ROW		0		1		2		3		4		5		6		7	
0 0 0 0	0	NUL	0 0 0		20 16 10	SP	40 32 20	0	60 48 30	Ä	100 64 40	P	120 80 50	ä	140 96 60	p	160 112 70
0 0 0 1	1		1 1 1	DC1 (XON)	21 17 11	!	41 33 21	1	61 49 31	A	101 65 41	Q	121 81 51	a	141 97 61	q	161 113 71
0 0 1 0	2		2 2 2		22 18 12	"	42 34 22	2	62 50 32	B	102 66 42	R	122 82 52	b	142 98 62	r	162 114 72
0 0 1 1	3		3 3 3	DC3 (XOFF)	23 19 13	#	43 35 23	3	63 51 33	C	103 67 43	S	123 83 53	c	143 99 63	s	163 115 73
0 1 0 0	4		4 4 4		24 20 14	\$	44 36 24	4	64 52 34	D	104 68 44	T	124 84 54	d	144 100 64	t	164 116 74
0 1 0 1	5	ENQ	5 5 5		25 21 15	%	45 37 25	5	65 53 35	E	105 69 45	U	125 85 55	e	145 101 65	u	165 117 75
0 1 1 0	6		6 6 6		26 22 16	&	46 38 26	6	66 54 36	F	106 70 46	V	126 86 56	f	146 102 66	v	166 118 76
0 1 1 1	7	BEL	7 7 7		27 23 17	'	47 39 27	7	67 55 37	G	107 71 47	W	127 87 57	g	147 103 67	w	167 119 77
1 0 0 0	8	BS	8 8 8	CAN	30 24 18	(50 40 28	8	70 56 38	H	110 72 48	X	130 88 58	h	150 104 68	x	170 120 78
1 0 0 1	9	HT	9 9 9		31 25 19)	51 41 29	9	71 57 39	I	111 73 49	Y	131 89 59	i	151 105 69	y	171 121 79
1 0 1 0	10	LF	10 A	SUB	32 26 1A	*	52 42 2A	:	72 58 3A	J	112 74 4A	Z	132 90 5A	j	152 106 6A	z	172 122 7A
1 0 1 1	11	VT	11 B	ESC	33 27 1B	+	53 43 2B	;	73 59 3B	K	113 75 4B	Æ	133 91 5B	k	153 107 6B	æ	173 123 7B
1 1 0 0	12	FF	12 C		34 28 1C	,	54 44 2C	<	74 60 3C	L	114 76 4C	Ø	134 92 5C	l	154 108 6C	ø	174 124 7C
1 1 0 1	13	CR	13 D		35 29 1D	-	55 45 2D	=	75 61 3D	M	115 77 4D	Å	135 93 5D	m	155 109 6D	å	175 125 7D
1 1 1 0	14	SO	14 E		36 30 1E	.	56 46 2E	>	76 62 3E	N	116 78 4E	Ü	136 94 5E	n	156 110 6E	ü	176 126 7E
1 1 1 1	15	SI	15 F		37 31 1F	/	57 47 2F	?	77 63 3F	O	117 79 4F	—	137 95 5F	o	157 111 6F	DEL	177 127 7F

KEY

ASCII CHARACTER

ESC	33
	27
	1B

OCTAL
DECIMAL
HEX

Figure F-10. Norwegian/Danish Character Set (7-bit)

NOTE

Empty positions are reserved for future use.

BITS		COLUMN		1		2		3		4		5		6		7					
B7	B6	0	0	0	0	0	0	0	0	0	0	0	0	0	0	0	0				
B5	B4	B3	B2	B1	ROW	0	1	2	3	4	5	6	7	8	9	A	B				
0	0	0	0	0	0	NUL	0		20	SP	40	0	60	§	100	P	120	`	140	p	160
							0		16		32		48		64		80		96		112
							0		10		20		30		40		50		60		70
0	0	0	1	1	1		1	DC1 (XON)	21	!	41	1	61	A	101	Q	121	a	141	q	161
							1		17		33		49		65		81		97		113
							1		11		21		31		41		51		61		71
0	0	1	0	2	2		2		22	"	42	2	62	B	102	R	122	b	142	r	162
							2		18		34		50		66		82		98		114
							2		12		22		32		42		52		62		72
0	0	1	1	3	3		3	DC3 (XOFF)	23	£	43	3	63	C	103	S	123	c	143	s	163
							3		19		35		51		67		83		99		115
							3		13		23		33		43		53		63		73
0	1	0	0	4	4		4		24	\$	44	4	64	D	104	T	124	d	144	t	164
							4		20		36		52		68		84		100		116
							4		14		24		34		44		54		64		74
0	1	0	1	5	5	ENQ	5		25	%	45	5	65	E	105	U	125	e	145	u	165
							5		21		37		53		69		85		101		117
							5		15		25		35		45		55		65		75
0	1	1	0	6	6		6		26	&	46	6	66	F	106	V	126	f	146	v	166
							6		22		38		54		70		86		102		118
							6		16		26		36		46		56		66		76
0	1	1	1	7	7	BEL	7		27	'	47	7	67	G	107	W	127	g	147	w	167
							7		23		39		55		71		87		103		119
							7		17		27		37		47		57		67		77
1	0	0	0	8	8	BS	10	CAN	30	(50	8	70	H	110	X	130	h	150	x	170
							8		24		40		56		72		88		104		120
							8		18		28		38		48		58		68		78
1	0	0	1	9	9	HT	11		31)	51	9	71	I	111	Y	131	i	151	y	171
							9		25		41		57		73		89		105		121
							9		19		29		39		49		59		69		79
1	0	1	0	10	12	LF	10	SUB	32	*	52	:	72	J	112	Z	132	j	152	z	172
							10		26		42		58		74		90		106		122
							10		1A		2A		3A		4A		5A		6A		7A
1	0	1	1	11	13	VT	11	ESC	33	+	53	;	73	K	113	i	133	k	153	o	173
							11		27		43		59		75		91		107		123
							11		1B		2B		3B		4B		5B		6B		7B
1	1	0	0	12	14	FF	12		34	,	54	<	74	L	114	~N	134	l	154	~n	174
							12		28		44		60		76		92		108		124
							12		1C		2C		3C		4C		5C		6C		7C
1	1	0	1	13	15	CR	13		35	-	55	=	75	M	115	¿	135	m	155	ç	175
							13		29		45		61		77		93		109		125
							13		1D		2D		3D		4D		5D		6D		7D
1	1	1	0	14	16	SO	14		36	.	56	>	76	N	116	^	136	n	156	~	176
							14		30		46		62		78		94		110		126
							14		1E		2E		3E		4E		5E		6E		7E
1	1	1	1	15	17	SI	15		37	/	57	?	77	O	117	_	137	o	157	DEL	177
							15		31		47		63		79		95		111		127
							15		1F		2F		3F		4F		5F		6F		7F

KEY

ASCII CHARACTER	ESC	3B	OCTAL
		27	DECIMAL
		1B	HEX

Figure F-11. Spanish Character Set (7-bit)

NOTE

Empty positions are reserved for future use.

7-bit/DEC 8-bit Translations

BITS		0 0		0 0 1		0 1 0		0 1 1		1 0 0		1 0 1		1 1 0		1 1 1	
B7 B6 B5		0 0		0 0 1		0 1 0		0 1 1		1 0 0		1 0 1		1 1 0		1 1 1	
B4 B3 B2 B1		COLUMN		1		2		3		4		5		6		7	
ROW		0		1		2		3		4		5		6		7	
0 0 0 0	0	NUL	0 0 0		20 16 10	SP	40 32 20	0	60 48 30	É	100 64 40	P	120 80 60	é	140 96 60	p	160 112 70
0 0 0 1	1		1 1 1	DC1 (XON)	21 17 11	!	41 33 21	1	61 49 31	A	101 65 41	Q	121 81 51	a	141 97 61	q	161 113 71
0 0 1 0	2		2 2 2		22 18 12	"	42 34 22	2	62 50 32	B	102 66 42	R	122 82 52	b	142 98 62	r	162 114 72
0 0 1 1	3		3 3 3	DC3 (XOFF)	23 19 13	#	43 35 23	3	63 51 33	C	103 67 43	S	123 83 53	c	143 99 63	s	163 115 73
0 1 0 0	4		4 4 4		24 20 14	\$	44 36 24	4	64 52 34	D	104 68 44	T	124 84 54	d	144 100 64	t	164 116 74
0 1 0 1	5	ENQ	5 5 5		25 21 15	%	45 37 25	5	65 53 35	E	105 69 45	U	125 85 55	e	145 101 65	u	165 117 75
0 1 1 0	6		6 6 6		26 22 16	&	46 38 26	6	66 54 36	F	106 70 46	V	126 86 56	f	146 102 66	v	166 118 76
0 1 1 1	7	BEL	7 7 7		27 23 17	'	47 39 27	7	67 55 37	G	107 71 47	W	127 87 57	g	147 103 67	w	167 119 77
1 0 0 0	8	BS	10 8 8	CAN	30 24 18	(50 40 28	8	70 56 38	H	110 72 48	X	130 88 58	h	150 104 68	x	170 120 78
1 0 0 1	9	HT	11 9 9		31 25 19)	51 41 29	9	71 57 39	I	111 73 49	Y	131 89 59	i	151 105 69	y	171 121 79
1 0 1 0	10	LF	12 10 A	SUB	32 26 1A	*	52 42 2A	:	72 58 3A	J	112 74 4A	Z	132 90 5A	j	152 106 6A	z	172 122 7A
1 0 1 1	11	VT	13 11 B	ESC	33 27 1B	+	53 43 2B	;	73 59 3B	K	113 75 4B	Ä	133 91 5B	k	153 107 6B	ä	173 123 7B
1 1 0 0	12	FF	14 12 C		34 28 1C	,	54 44 2C	<	74 60 3C	L	114 76 4C	Ö	134 92 5C	l	154 108 6C	ö	174 124 7C
1 1 0 1	13	CR	15 13 D		35 29 1D	-	55 45 2D	=	75 61 3D	M	115 77 4D	Å	135 93 5D	m	155 109 6D	å	175 125 7D
1 1 1 0	14	SO	16 14 E		36 30 1E	.	56 46 2E	>	76 62 3E	N	116 78 4E	Ü	136 94 5E	n	156 110 6E	ü	176 126 7E
1 1 1 1	15	SI	17 15 F		37 31 1F	/	57 47 2F	?	77 63 3F	O	117 79 4F	—	137 95 5F	o	157 111 6F	DEL	177 127 7F

KEY

ASCII CHARACTER



OCTAL
DECIMAL
HEX

Figure F-12. Swedish Character Set (7-bit)

NOTE

Empty positions are reserved for future use.

BITS		0 0		0 0 1		0 1 0		0 1 1		1 0 0		1 0 1		1 1 0		1 1 1				
COLUMN		0		1		2		3		4		5		6		7				
B4	B3	B2	B1	ROW																
0	0	0	0	0	NUL	0 0 0		20 16 10	SP	40 32 20	0	60 48 30	à	100 64 40	P	120 80 50	ô	140 96 60	p	160 112 70
0	0	0	1	1		1 1 1	DC1 (XON)	21 17 11	!	41 33 21	1	61 49 31	A	101 65 41	Q	121 81 51	a	141 97 61	q	161 113 71
0	0	1	0	2		2 2 2		22 18 12	"	42 34 22	2	62 50 32	B	102 66 42	R	122 82 52	b	142 98 62	r	162 114 72
0	0	1	1	3		3 3 3	DC3 (XOFF)	23 19 13	£	43 35 23	3	63 51 33	C	103 67 43	S	123 83 53	c	143 99 63	s	163 115 73
0	1	0	0	4		4 4 4		24 20 14	\$	44 36 24	4	64 52 34	D	104 68 44	T	124 84 54	d	144 100 64	t	164 116 74
0	1	0	1	5		5 5 5		25 21 15	%	45 37 25	5	65 53 35	E	105 69 45	U	125 85 55	e	145 101 65	u	165 117 75
0	1	1	0	6		6 6		26 22 16	&	46 38 26	6	66 54 36	F	106 70 46	V	126 86 56	f	146 102 66	v	166 118 76
0	1	1	1	7		7 7 7		27 23 17	'	47 39 27	7	67 55 37	G	107 71 47	W	127 87 57	g	147 103 67	w	167 119 77
1	0	0	0	8	BS	10 8 8	CAN	30 24 18	(50 40 28	8	70 56 38	H	110 72 48	X	130 88 58	h	150 104 68	x	170 120 78
1	0	0	1	9	HT	11 9 9		31 25 19)	51 41 29	9	71 57 39	I	111 73 49	Y	131 89 59	i	151 105 69	y	171 121 79
1	0	1	0	10	LF	12 10 A	SUB	32 26 1A	*	52 42 2A	:	72 58 3A	J	112 74 4A	Z	132 90 5A	j	152 106 6A	z	172 122 7A
1	0	1	1	11	VT	13 11 B	ESC	33 27 1B	+	53 43 2B	;	73 59 3B	K	113 75 4B	é	133 91 5B	k	153 107 6B	ä	173 123 7B
1	1	0	0	12	FF	14 12 C		34 28 1C	,	54 44 2C	<	74 60 3C	L	114 76 4C	ç	134 92 5C	l	154 108 6C	ö	174 124 7C
1	1	0	1	13	CR	15 13 D		35 29 1D	-	55 45 2D	=	75 61 3D	M	115 77 4D	ê	135 93 5D	m	155 109 6D	ü	175 125 7D
1	1	1	0	14	SO	16 14 E		36 31 1E	.	56 46 2E	>	76 62 3E	N	116 78 4E	î	136 94 5E	n	156 110 6E	û	176 126 7E
1	1	1	1	15	SI	17 15 F		37 31 1F	/	57 47 2F	?	77 63 3F	O	117 79 4F	è	137 95 5F	o	157 111 6F	DEL	177 127 7F

KEY

ASCII CHARACTER	ESC	33	OCTAL
		27	DECIMAL
		1B	HEX

Figure F-13. Swiss Character Set (7-bit)

NOTE

Empty positions are reserved for future use.

7-bit/DEC 8-bit Translations

BITS		0 0		0 0 1		0 1 0		0 1 1		1 0 0		1 0 1		1 1 0		1 1 1	
BITS		COLUMN		1		2		3		4		5		6		7	
B4	B3 B2 B1	0	1	0	1	0	1	0	1	0	1	0	1	0	1	0	1
ROW		0	1	2	3	4	5	6	7	8	9	10	11	12	13	14	15
0 0 0 0	0	NUL				SP		0		@		P		`		p	
0 0 0 1	1		DC1 (XON)		!		1		A		Q		a		q		
0 0 1 0	2				"		2		B		R		b		r		
0 0 1 1	3		DC3 (XOFF)				3		C		S		c		s		
0 1 0 0	4				\$		4		D		T		d		t		
0 1 0 1	5	ENQ			%		5		E		U		e		u		
0 1 1 0	6				&		6		F		V		f		v		
0 1 1 1	7	BEL			'		7		G		W		g		w		
1 0 0 0	8	BS		CAN	(8		H		X		h		x		
1 0 0 1	9	HT)		9		I		Y		i		y		
1 0 1 0	10	LF		SUB	*		:		J		Z		j		z		
1 0 1 1	11	VT		ESC	+		;		K		[k		{		
1 1 0 0	12	FF			,		<		L		\		l				
1 1 0 1	13	CR			-		=		M]		m		}		
1 1 1 0	14	SO			.		>		N		^		n		~		
1 1 1 1	15	SI			/		?		O		_		o		DEL		

KEY

ASCII CHARACTER

ESC	39
	27
	1B

OCTAL
DECIMAL
HEX

Figure F-14. United Kingdom Character Set (7-bit)

NOTE

Empty positions are reserved for future use.



Options

This appendix lists and describes options that you can purchase for your Rainbow computer.

Additional Memory

You can increase the memory capacity of your Rainbow computer by installing additional memory. The Rainbow computer comes with 64K bytes or 256K. If you purchase the memory option, you can choose either 128K bytes or 256K bytes of additional memory. If you choose 256K bytes, you can expand this to 768K bytes of additional memory.

The memory option module fits on the system module. After you install the additional memory, a message displays on the screen with the new memory size.

See Owner's Manual - MESSAGE 24 - New Memory Size = nnnk

The Set-Up screens also display the new memory size.

Second Dual-Diskette Drive

You can add a second drive, which holds two additional diskettes, to your Rainbow computer. This dual-diskette drive fits beside the original dual-diskette drive in the system unit. You can access the diskettes in the optional dual-diskette drive by selecting either of the following from the Main System Menu:

C = start from Drive C
D = start from Drive D

You can also have the Rainbow computer auto-boot from either of these drives.

Hard (Winchester) Disk

You can add the hard disk option to your Rainbow computer. It includes the following.

- Hard disk drive
- Hard disk controller board
- Hard disk drive cable

The hard disk is a rigid disk (as compared with the diskette which is floppy). It holds 10 megabytes of storage and is equivalent to 25 diskettes. The disk can be logically partitioned into various size sections:

	8 megabytes (large section)		2.5 megabytes
+	2 megabytes (small section)		2.5 megabytes
	<hr/>	or	2.5 megabytes
	10 megabytes		2.5 megabytes
			<hr/>
			10.0 megabytes

You can access the hard disk by selecting:

W = start from Drive W

on the Main System Menu. You can also have the Rainbow computer auto-boot from the hard disk drive. Many operating systems can be on the disk together.

For more information on the hard disk option see the chapter on the hard disk in your *Rainbow™ User's Guide*.

Extended Communications

The extended communications option provides communications capabilities beyond those provided with the standard communications connector. It has two serial ports:

- A high-speed serial port
- A low-speed serial port

The extended communications option also provides:

- Direct memory access for input/output devices
- Support of many communications protocols.

Color/Graphics Option

You can install this option to give your Rainbow computer additional graphics and color display. There are two resolution modes:

- High resolution (800 × 240 pixels; 2 planes). This provides four simultaneous colors from a palette of 4096. If you are using the Rainbow black and white monitor, these colors translate to four distinctive gray levels including black and white.
- Medium resolution (384 × 240 pixels; 4 planes). This provides 16 simultaneous colors from a palette of 4096. If you are using the Rainbow black and white monitor, these colors translate to 16 distinctive gray levels including black and white.

Some of the additional graphics features of this option include the following.

- Scrolling: smooth, horizontal, and vertical
- Patterning: a pattern generator/multiplier for tiling and texturing of graphics patterns and line segments
- Read-back: a feature that reads each plane back to the Rainbow computer's memory for diagnostics or other purposes

If you attach a printer or pen plotter to the Rainbow computer, you can get a printed copy of the graphics displayed on the screen.

VR241A Color Monitor

The color monitor provides high-quality color graphics. The color monitor displays the colors generated by the color/graphics option enhancing the capabilities of your Rainbow computer.

Color Monitor Specifications

Height:	31.9 cm (12.75 in)
Width:	36.3 cm (14.5 in)
Depth:	38.6 cm (15.5 in)
Weight:	15.8 kg (35 lbs)
Video screen:	33 cm (13 in) diagonal, high-resolution color
Dot pitch:	.31 mm resolution (shadow mask)
Active raster size:	240 mm width × 150 mm height
Interface:	Standard RS-170 RGB (red-green-blue) cable connector with built-in line termination and selectable external synch.
Power supply:	Universal, switch-selectable – 90 Vac–120 Vac, 47 Hz–63 Hz or 185 Vac–256 Vac, 47 Hz–63 Hz

Printer

Three personal printers are available for your Rainbow computer from Digital Equipment Corporation.

- LA100 Letterprinter 100
- LA50 Personal Printer
- LQP02 Letter-Quality Printer

Refer to Chapter 4, *Connecting a Printer to Your Rainbow Computer*. You can also refer to each printer's documentation.

Floor Stand

The floor stand holds the system unit. It stands vertically on the floor to give you more desk space.

Rainbow Control Functions

Introduction

The Rainbow computer is an upward and downward software compatible terminal. It generates and responds to control functions of previous Digital terminals, such as the VT52 DECscope. It also generates and responds to control functions that have since been standardized by the American National Standards Institute (ANSI).

ANSI standards define a method of controlling a computer using a technique using control sequences. Control sequences are coded in a program as a string of two or more characters.

For example, the sequence

```
ESC [ B n
```

requests a status report of the device you are using.

You can set the Rainbow computer to use either VT52 control functions or ANSI control functions, a Set-Up feature. However, the ANSI selection contains more control capabilities and is therefore more flexible with current operating system software. The VT52 selection is only used with older Digital software on remote systems in terminal mode. For information on VT52 control functions, refer to the *VT100 User's Guide* (EK-VT100-UG).

Using Control Functions

You can use control functions to:

1. Change Set-Up features
2. Select modes:
 - a. ANSI/VT52
 - b. Scrolling (define top and bottom margins)
 - c. Origin
 - d. Cursor position
 - e. Column (columns per line)
 - f. Auto-wrap – screen background (light or dark)
 - g. Line feed/new line
 - h. Keyboard action
 - i. Send-receive (local echo; only in terminal mode)
 - j. Cursor key character selection
 - k. Auto-repeat
 - l. Set/reset
 - m. Keypad selection (application or numeric)
3. Select a character set

4. Select character features:
 - a. Underlining
 - b. Reverse video
 - c. Blink
 - d. Bold
 - e. Any combination of the above
5. Change tab stops
6. Select line features:
 - a. Single-height/single-width
 - b. Single-height/double-width
 - c. Double-height/double-width
7. Erase characters and lines
8. Do computer editing:
 - a. Delete characters
 - b. Insert and delete lines
 - c. Insert or replace characters
9. Print in terminal mode
10. Request and receive reports:
 - a. Device status (which devices are connected to the computer)
 - b. Cursor position
 - c. Device attributes
 - d. Computer identification
11. Present a screen alignment display

ANSI Mode Control Functions

Definitions – The following listing briefly defines the basic elements of ANSI control functions.

1. Control sequence introducer (CSI) – A prefix to a control sequence. In the Rainbow computer, ESC [is the CSI.
2. Parameter –
 - a. A string of 0 or more decimal characters that represent a single value. Leading 0s are ignored. Characters have a range of 0 to 9.
 - b. The value so represented.
3. Numeric parameter – A parameter that represents a number, designated by Pn.
4. Selective parameter – A parameter that selects a subfunction from a specified list, designated by Ps.
5. Parameter string – A string of parameters separated by a semicolon.
6. Default value – A value that is assumed when no explicit value, or a value of 0, is specified.
7. Final character – A character that terminates a control sequence or escape sequence.

Examples:

1. General

selective
parameter

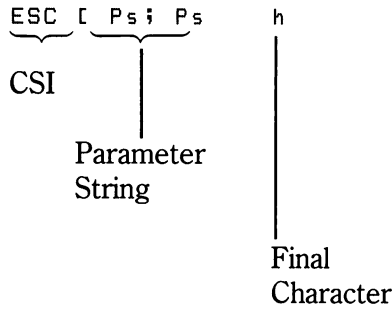

2. Escape sequence for double-width line (DEC DWL).

Escape Sequence	Octal Representation of Same Sequence
ESC # 6	033 043 066

3. Control sequence to set 132 column mode.

Control Sequence	Octal Representation of Same Sequence
ESC [? 3 h	033 133 037 063 150
CSI Final Character Parameter	CSI Parameter Final Character

The remainder of this appendix lists all control functions grouped according to their function.

Control and escape sequences are printed in color; their octal representations are printed in black.

Set-Up Features and Mode Selection

Set-Up features change the way the Rainbow computer operates. You can select these features from the keyboard or through control functions.

Some Set-Up features are modes. A mode affects either the Rainbow computer operation or the way the computer understands and transmits data. The Rainbow computer uses the selected mode until you use the keyboard or a control function to change the selection. Table H-1 lists these Set-Up features and modes.

Table H-1. Set-Up Features and Modes

Set-Up Feature or Mode	Change by Control Function	Change from Keyboard in Set-Up
On/off line**	No	Yes
Columns per line	Yes	Yes
Tab stops	Yes*	Yes
Scroll rate	No	Yes
Auto-repeat	Yes	Yes
Screen background	Yes	Yes
Cursor	No	Yes
Margin bell volume	No	Yes
Keyclick volume	No	Yes
ANSI/VT52	Yes	Yes
Auto XON/XOFF**	No	Yes
US/UK default character set	Yes*	Yes
Auto-wrap	Yes	Yes
Line feed/new line	Yes	Yes
Local echo**	Yes	Yes
Print termination character**	Yes	Yes
Printer extent**	Yes	Yes
One or two stop bits	No	Yes
Receive parity	No	Yes
Break enable**	No	Yes
Disconnect character enable**	No	Yes
Disconnect delay**	No	Yes
Auto-answerback enable**	No	Yes

Table H-1. Set-Up Features and Modes (Cont)

Set-Up Feature or Mode	Change by Control Function	Change from Keyboard in Set-Up
Power (50 Hz/60 Hz)	No	Yes
Modem data/parity bits	No	Yes
Transmit speed	No	Yes
Receive speed	No	Yes
Modem control**	No	Yes
Printer data/parity bits	No	Yes
Printer transmit/receive speed	No	Yes
Keypad application/numeric mode	Yes*	No
Cursor key mode	Yes	No
Origin mode	Yes	No
Insertion-replacement mode	Yes	No

* These features are not changed using the set mode (SM) and reset mode (RM) sequences.

**In terminal mode only.

Most modes are changed by using set mode and reset mode control sequences. Set and reset the modes by using the following control sequences.

Set Mode

```
ESC [ Ps ; ... ; Ps h
033 133 *** 073 073 *** 150
```

Set mode sets one or more modes specified by selective parameters (P_s) in the parameter string.

NOTE

P_s represents a variable parameter selected from a list of parameters. In the second line, a series of asterisks (***) represents the parameter. The parameter is transmitted using decimal ASCII characters. For example, decimal 12 consists of the digits 1 and 2. When you set several modes with a single SM or RM sequence, a semicolon separates parameters.

Reset Mode

```
ESC [ Ps ; ... ; Ps ]  
033 133 *** 073 073 *** 154
```

Reset mode sets one or more modes specified by selective parameters (Ps) in the parameter string.

Table H-2 lists the ANSI-specified modes and their parameters (Ps). Table H-3 lists the ANSI-compatible private modes and their selective parameters. When you change ANSI-compatible private modes, the first character in the parameter string is a question mark (? , octal 077). All parameters in the sequence are interpreted as ANSI-compatible private parameters. This appendix explains each mode in detail and provides the sequences to set and reset each mode.

Table H-2. ANSI-Specified Modes

Name	Parameter (Ps)
Error (ignored)	0
Keyboard action	2
Insertion-replacement	4
Line feed/new line	20

Table H-3. ANSI-Compatible Private Modes

Name	Parameter (Ps)
Error (ignored)	0
Cursor key	1
ANSI/VT52	2
Column	3
Scroll	4
Screen	5
Origin	6
Auto-wrap	7
Auto-repeat	8
Printer form feed*	18
Printer extent*	19

*In terminal mode only.

The following example shows the use of the question mark (used with ANSI private parameters) and semicolon (used with multiple parameters). The sequence sets both column and scroll modes.

```
ESC [ ? 3 ; 4 h
033 133 077 063 073 064 150
```

Table H-4 describes modes specified in ANSI X3.64-1979 that are permanently set, permanently reset, or not applicable. See the ANSI standard for more information about these modes.

NOTE

The application keypad and numeric keypad modes are selected using dedicated escape sequences, not set and reset mode control sequences. See Keypad Character Selection in this appendix for more information.

Table H-4. Permanently Selected Modes

Name	Selection	Function
Control	Reset	Rainbow computer representation performs control functions without displaying a character to represent control function received.
Editing boundary	Reset	Characters moved outside the margins are lost; computer does not perform erasing and cursor positioning functions outside the margins. This does not affect horizontal and vertical position and cursor position sequences.
Erasure	Set	All characters displayed can be erased.
Format effector action	Reset	Computer immediately performs control functions that affect the screen display.
Format effector transfer	N/A	—

Table H-4. Permanently Selected Modes(Cont)

Name	Selection	Function
Guarded area transfer	N/A	-
Horizontal editing	N/A	-
Multiple area transfer	N/A	-
Positioning unit	Reset	Computer specifies horizontal and vertical positioning parameters in control functions in units of character position.
Selected area transfer	N/A	-
Status reporting	Reset	Computer transmits transfer status reports by using device status report sequences.
Tabulation stop	N/A	-
Vertical editing	N/A	-

Scrolling

Scrolling is the upward or downward movement of existing lines on the screen. This makes room for more display lines at either the top or bottom of the scrolling region. There are two methods of scrolling: jump scroll and smooth scroll. You select the type of scrolling by using the following sequences.

Set Scroll Mode

```
ESC [ ? 4 h  
033 133 077 064 150
```

When set, this sequence selects smooth scroll. You set the smooth scroll rate in Set-Up.

Reset Scroll Mode

```
ESC [ ? 4 1  
033 133 077 064 154
```

When reset, this sequence selects jump scroll. Jump scroll lets the computer add lines to the screen as fast as possible.

Scrolling Region

The scrolling region is the area of the screen defined by and including the top and bottom margins. The margins determine which screen lines move during scrolling. Characters added outside the scrolling region do not cause the screen to scroll. The minimum size of the scrolling region is two lines. Therefore, the line number of the top margin must be less than the number of the bottom margin. The origin mode selects line numbers relative to the whole screen or the scrolling region.

After the margins are selected, the cursor moves to the home position (line 1, column 1). The origin mode feature also affects the home position. You select the top and bottom margins of the scrolling region by using the following control sequence.

NOTE

When you power up or use the system reset command, the scrolling region becomes the full screen.

Pt and Pb represent variable numeric parameters. The parameters are decimal numbers transmitted to the computer as ASCII characters. Asterisks (***) represent one or more variable numeric parameters in the octal sequence.

Set Top and Bottom Margins

```
ESC [ Pt ; Pb r  
033 133 *** 073 *** 162
```

This sequence selects top and bottom margins, defining the scrolling region. Pt is the line number of the first line in the scrolling region. Pb is the line number of the bottom line. If Pt and Pb are not selected, the complete screen is used (no margins).

Origin Mode

The origin mode determines if the cursor can move outside the scrolling region (the area between the top and bottom margins). You can move the cursor outside the margins with the cursor position and horizontal and vertical position sequences.

Lines on the screen are numbered according to the location of the home position. The cursor moves to the new home position whenever origin mode is selected. You select origin mode by using the following sequences.

NOTE

When you power up or use the system reset command, origin mode resets.

Set Origin Mode

```
ESC [ ? 6 h  
033 133 077 066 150
```

This sequence selects home position in scrolling region. Line numbers start at top margin of scrolling region. The cursor cannot move out of the scrolling region.

Reset Origin Mode

```
ESC [ ? 6 1  
033 133 077 066 154
```

This sequence selects home position in upper-left corner of screen. Line numbers are independent of the scrolling region (absolute). Use cursor position and horizontal and vertical position sequences to move cursor out of scrolling region.

Cursor Positioning

The cursor indicates the active screen position where the computer will display the next character. The cursor moves:

1. One column to the right when the computer displays a character if the cursor is at the beginning of the line. If the line is filled and auto-wrap is enabled, the line may scroll if the cursor is at the end of the line.
2. One line down after a line feed (LF, octal 012), form feed (FF, octal 014), or vertical tab (VT, octal 013) (line feed/new line may also move the cursor to the left margin). If the cursor is at the bottom margin, this causes an upward scroll.
3. One line up after a reverse index, if the cursor is at the top margin, it causes a downward scroll.
4. To the left margin after a carriage return (CR, octal 015).
5. One column to the left after a backspace (BS, octal 010). If the cursor is already at the beginning of the line, there is no movement.
6. To the next tab stop (or right margin, if no tabs are set) after a horizontal tab character (HT, octal 011).
7. To the home position when the top and bottom margins of the scrolling region or origin mode selection changes.

You can also move the cursor by using the following sequences.

Cursor Up

```
ESC [ Pn A  
033 133 *** 101
```

This sequence moves cursor up Pn lines in same column. Cursor stops at top margin.

NOTE

Pn represents a variable numeric parameter. The parameter is a decimal number transmitted to the computer by using ASCII characters. If you select no parameter or 0, the computer assumes the parameter equals 1. Asterisks (***) represent one or more characters in the octal sequence.

Cursor Down

```
ESC [ Pn B  
033 133 *** 102
```

This sequence moves cursor down Pn lines in same column. Cursor stops at bottom margin.

Cursor Forward

```
ESC [ Pn C  
033 133 *** 103
```

This sequence moves cursor right Pn columns. Cursor stops at right margin.

Cursor Backward

```
ESC [ Pn D  
033 133 *** 104
```

This sequence moves the cursor left Pn columns. Cursor stops at left margin.

Cursor Position

```
ESC [ P1 ; Pc H  
033 133 *** 073 *** 110
```

This sequence moves the cursor to line P1, column Pc. If P1 or Pc are not selected or selected as 0, the cursor moves to first line or column, respectively. Origin mode selects line numbering and has the ability to move the cursor into margins.

NOTE

P1 and Pc represent variable numeric parameters. The parameter is a decimal number that represents one or more characters transmitted to the computer as ASCII characters. Asterisks (***) represent the variable parameter in the octal sequence.

The cursor position sequence operates the same as the horizontal and vertical position sequence.

Cursor Position (Home)

```
ESC [ H  
033 133 110
```

This sequence moves the cursor to home position, selected by origin mode.

Horizontal and Vertical Position

```
ESC [ P1 ; Pc f  
033 133 *** 073 *** 146
```

This sequence moves the cursor to line P1, column Pc. If P1 or Pc are not selected or selected as 0, the cursor moves to first line or column, respectively. Origin mode selects line numbering and ability to move the cursor into margins.

The horizontal and vertical position sequence operates the same as the cursor position sequence.

Horizontal and Vertical Position (Home)

```
ESC [ f  
033 133 146
```

Cursor moves to home position selected by origin mode.

Index

```
ESC D or IND  
033 104 204
```

This sequence moves the cursor down one line in same column. If the cursor is at the bottom margin, the screen performs a scroll-up.

Reverse Index

```
ESC M or RI  
033 115 215
```

This sequence moves the cursor up one line in the same column. If the cursor is at the top margin, the screen performs a scroll-down.

Next Line

```
ESC E or NEL  
033 105 205
```

This sequence moves the cursor to the first position on the next line. If the cursor is at the bottom margin, the screen performs a scroll-up.

Save Cursor

```
ESC 7  
033 067
```

This sequence saves cursor position, character attribute (graphic rendition), character set, and origin mode selection. (See restore cursor.)

Restore Cursor

```
ESC B  
033 070
```

This sequence restores previously saved cursor position, character attribute (graphic rendition), character set, and origin mode selection. If none were saved, the cursor moves to home position.

Columns Per Line

This mode selects the number of columns in a display line, 80 or 132. With either selection, the screen can display 24 lines. Select the number of columns per line by using the following control sequences.

NOTE

When you change the number of columns per line, the screen is erased. This also sets the scrolling region for full screen (24 lines) and sets all lines to single-height, single-width.

Set Column Mode

```
ESC [ ? 3 h  
033 133 077 063 150
```

This sequence selects 132 columns per line.

Reset Column Mode

```
ESC [ ? 3 l  
033 133 077 063 154
```

This sequence selects 80 columns per line.

Auto-Wrap

This mode selects where a received character will be displayed when the cursor is at the right margin. You select auto-wrap by using the following control sequences.

NOTE

Regardless of your auto-wrap Set-Up feature selection, the tab character never moves the cursor to the next line.

Set Auto-Wrap Mode

```
ESC [ ? 7 h  
033 133 077 067 150
```

This sequence selects auto-wrap. Any display characters received when cursor is at right margin are displayed on the next line. The display scrolls up if cursor is at end of the scrolling region.

Reset Auto-Wrap Mode

```
ESC [ ? 7 l  
033 133 077 067 154
```

This sequence turns auto-wrap off. Display characters received when cursor is at right margin replace previously displayed character.

Screen Mode (Background)

This mode selects either light (reverse) or dark display background on the screen. You select screen mode by using the following control sequences.

Set Screen Mode

```
ESC [ ? 5 h  
033 133 077 065 150
```

This sequence selects reverse screen, a white screen background with black characters.

Reset Screen Mode

```
ESC [ ? 5 1
033 133 077 065 154
```

This sequence selects normal screen, a black screen background with white characters.

Line Feed/New Line

This mode selects the control character(s) transmitted by **Return**. The line feed/new line mode also selects the action taken by the computer when receiving line feed, form feed, and vertical tab. Table H-5 provides a summary of the feature. You select line feed/new line mode by using the following control sequences.

Table H-5. Line Feed/New Line Feature

Feature Selection	Key Pressed	Character Sent	Character Function Received
Off (reset)	Return	CR	CR – cursor moves to left margin.
Off (reset)	LF (line feed)	LF	LF, FF, VT – cursor moves to next line but stays in same column.
On (set)	Return	CR LF	CR – cursor moves to the left margin of the next line.
On (set)	LF (line feed)	LF CR	LF, FF, VT – cursor moves to left margin of next line.

Set Line Feed/New Line Mode

```
ESC [ 2 0 h
033 133 062 060 150
```

This sequence causes a received line feed, form feed, or vertical tab to move cursor to first column of next line. Pressing the **Return** key transmits both a carriage return and line feed. This selection is also called new line option.

Reset Line Feed/New Line Mode

```
ESC [ 2 0 1  
033 133 062 060 154
```

This sequence causes a received line feed, form feed, or vertical tab to move cursor to next line in current column. Pressing the **Return** key transmits a carriage return.

Keyboard Action Mode

Keyboard action mode lets the computer turn the keyboard on or off. This mode always resets when you enter Set-Up. You select keyboard action mode by using the following control sequences.

Set Keyboard Action Mode

```
ESC [ 2 h  
033 133 062 150
```

This sequence turns off the keyboard and turns on the Wait indicator.

Reset Keyboard Action Mode

```
ESC [ 2 l  
033 133 062 154
```

This sequence turns on the keyboard and turns off the Wait indicator.

Auto-Repeat Mode

This mode selects automatic key repeating. If you press a key for more than one-half second, the computer automatically repeats the transmission of the character. Key repeating does not affect **Set-Up**, **ESC**, and **Hold Screen**. You select auto-repeat mode by using the following sequences.

Set Auto-Repeat Mode

```
ESC [ ? 8 h  
033 133 077 070 150
```

This sequence selects auto-repeat. If you press a key for more than one-half second, it automatically repeats.

Reset Auto Repeat Mode

```
ESC [ ? 8 1  
033 133 077 070 154
```

This sequence turns off auto-repeat. Keys do not automatically repeat.

Local Echo (Keyboard Send-Receive Mode)

This mode selects local echo (only in terminal mode) which causes every character transmitted by the Rainbow computer to be automatically displayed on the screen. Therefore, the host computer does not have to transmit (echo) the character back to the Rainbow computer for display. When local echo is off, the Rainbow computer only transmits characters to the host computer. The host computer must echo the characters back to the Rainbow computer for display. You select send-receive mode by using the following control sequences.

Set Send-Receive Mode

```
ESC [ 1 2 h  
033 133 061 062 150
```

This sequence turns off local echo. The Rainbow computer transmits characters to the host computer, which must echo characters for display on screen.

Reset Send-Receive Mode

```
ESC [ 1 2 1  
033 133 061 062 154
```

This sequence selects local echo. The computer automatically displays characters transmitted to the host computer on the screen.

Cursor Key Character Selection

Cursor key mode selects the set of characters transmitted by the cursor keys. See Table H-6 for the codes transmitted by the cursor keys. You select cursor key mode by using the following control sequences.

NOTE

When you power up or use a system reset command, cursor key mode resets.

Table H-6. ANSI Cursor Control Key Codes

Cursor Key	Cursor Key Mode Reset Sends Cursor Control Sequence	Cursor Key Mode Set Generates Application Functions
Up ⬆	ESC [A 033 133 101	ESC O A 033 117 101
Down ⬇	ESC [B 033 133 102	ESC O B 033 117 102
Right ➡	ESC [C 033 133 103	ESC O C 033 117 103
Left ⬅	ESC [D 033 133 104	ESC O D 033 117 104

Set Cursor Key Mode

```
ESC [ ? 1 h
033 133 077 061 150
```

This sequence selects cursor keys to generate (application) functions.

Reset Cursor Key Mode

```
ESC [ ? 1 l
033 133 077 061 154
```

This sequence selects cursor keys to generate cursor control sequences.

Keypad Character Selection

The numeric keypad generates either numeric characters or control functions. Selecting application or numeric keypad mode determines the type of characters. The program function (PF) keys generate the same characters regardless of the keypad character selection. See Table H-7 for the characters generated by the keypad. You select the keypad mode by using the following escape sequences.

NOTE

When you power up or use a system reset command, the computer selects numeric keypad mode.

Select Application Keypad Mode

```
ESC =
033 075
```

This sequence selects application keypad mode. Keypad generates control functions.

Table H-7. ANSI Keypad Codes

Key	Numeric Keypad Mode Codes	Application Keypad Mode Codes
0	0 060	ESC O p 033 117 160
1	1 061	ESC O q 033 117 161
2	2 062	ESC O r 033 117 162
3	3 063	ESC O s 033 117 163
4	4 064	ESC O t 033 117 164
5	5 065	ESC O u 033 117 165
6	6 066	ESC O v 033 117 166
7	7 067	ESC O w 033 117 167
8	8 070	ESC O x 033 117 170
9	9 071	ESC O y 033 117 171
– (minus)	– (minus) 055	ESC O m 033 117 155
, (comma)	, (comma) 054	ESC O l 033 117 154
.(period)	.(period) 056	ESC O n 033 117 156
ENTER*	CR or CR LF 015 015 012	ESC O M 033 117 115
PF1	ESC O P 033 117 120	ESC O P 033 117 120

Table H-7. ANSI Keypad Codes (Cont)

Key	Numeric Keypad Mode Codes	Application Keypad Mode Codes
PF2	ESC O Q 033 117 121	ESC O Q 033 117 121
PF3	ESC O R 033 117 122	ESC O R 033 117 122
PF4	ESC O S 033 117 122	ESC O S 033 117 123

* In numeric keypad mode, the **Enter** key generates the same characters as the **Return** key. You can change the **Return** key character code with the line feed/new line feature. When off, this feature causes the **Enter** key to generate a single control character (CR, octal 015). When on, this feature causes the **Enter** key to generate two characters (CR, octal 015 and LF, octal 012).

Select Numeric Keypad Mode

```
ESC >
033 076
```

This sequence selects numeric keypad mode. Keypad generates characters that match the numeric, comma, period, and minus sign keys on the main keyboard.

NOTE

In ANSI mode, if the codes are echoed back to the computer or if the computer is off-line, the last character of the escape sequence is displayed on the screen; for example, PF4 is displayed as an S.

Character Set Selection (GO)

Select U.K. Character Set

```
ESC ( A
033 050 101
```

Cursor Position Report

Request Cursor Position Report

```
ESC [ G n  
033 133 066 156
```

The computer response is:

```
ESC [ P1 ; Pc R  
033 133 *** 073 *** 122
```

Computer reports cursor position in response to the Device Status Report sequence request. P1 indicates line and Pc indicates column. No parameters, or parameters of 0, indicate cursor is at the home position. Origin mode determines whether line numbering is relative to the top of the screen or the top of the scrolling region.

Device Attributes

Request Rainbow Computer Identification

```
ESC [ c or ESC [ O c  
033 133 143 033 133 060 143
```

Identify Terminal

```
ESC Z  
033 132
```

A request for Rainbow computer identification. Rainbow computer uses device attributes to respond. Future Digital computers may not support this sequence. Therefore, new software should use device attributes.

Request Device Attributes

```
ESC [ ? G c  
033 133 077 066 143
```

Rainbow response: "I am a VT102."

Reset to Initial State

Reset the Computer to Its Initial State

ESC c
033 143

NOTE

It is recommended that this not be used due to unpredictable results.

Screen Alignment Adjustments

The computer has a screen alignment pattern that lets Field Service personnel adjust the screen. Display the screen alignment pattern by using the following sequence.

Display Screen Alignment

ESC # 8
033 043 070

Fills screen with uppercase Es for screen focus and alignment. This command is used by Digital Manufacturing and Field Service personnel.

VT52-Compatible Control Functions

VT52-compatible control functions meet Digital standards. Therefore, the computer can use existing software designed for previous computers (such as the VT52). You can select VT52 compatibility from the keyboard in Set-Up or the computer can use a sequence.

NOTE

In VT52 mode, control characters and displayable characters are processed just as in ANSI mode.

Select U.S. Character Set

```
ESC ( B  
033 050 102
```

Select Special Characters and Line Drawing Character Set

```
ESC ( 0  
033 050 060
```

Character Set Selection (G1)

Select U.K. Character Set

```
ESC ) A  
033 051 101
```

Select U.S. Character Set

```
ESC ) B  
033 051 102
```

Select Special Characters and Line Drawing Character Set

```
ESC ) 0  
033 051 060
```

Select G2 and G3 for one character by using the following escape sequences.

Select Single Shift 2

```
ESC N 0F SS2  
033 116 216
```

This sequence selects G2 (default) character set for one character. You select G2 in Set-Up.

Select Single Shift 3

```
ESC O or SS3  
033 117 217
```

This sequence selects G3 (default) character set for one character. You select G3 in Set-Up.

Character Attributes

The computer can display the following character attributes that change the character display without changing the character.

1. Underline
2. Reverse video (character background opposite of the screen background feature)
3. Blink
4. Bold (increased intensity)
5. Any combination of these attributes (applied in the order of reception)

You can select one or more character attributes at one time. Selecting an attribute does not turn off other attributes already selected. After you select an attribute, all characters received by the computer are displayed with that attribute. If you move the characters by scrolling, the attribute moves with the characters. You select the character attributes by using the following control sequences.

Turn Off Character Attributes

```
ESC [ m or ESC [ O m  
033 133 155 033 133 060 155
```

Select Bold (Increased Intensity)

```
ESC [ 1 m  
033 133 061 155
```

Select Underline

```
ESC [ 4 n  
033 133 064 155
```

Select Blink

```
ESC [ 5 m  
033 133 064 155
```

Select Reverse Video

```
ESC [ 7 m  
033 133 067 155
```

Tab Stops

You select tab stop positions on the horizontal lines of the screen. The cursor advances (tabs) to the next tab stop when the computer receives a horizontal tab (HT, octal 011). If no tab stops are set, horizontal tab moves the cursor to the right margin. Set and clear the tab stops by using the following sequences.

Set Horizontal Tabulation

```
ESC H 01 HTS  
033 110 210
```

This sequence sets a horizontal tab stop at the current cursor position.

Clear Tab Stop

```
ESC [ g 01 ESC [ 0 g  
033 133 147 033 133 060 147
```

This sequence clears a horizontal tab stop at the current cursor position.

Clear All Horizontal Tab Stops

```
ESC [ 3 g  
033 133 063 147
```

Line Attributes

These are display features that affect a complete display line. The cursor selects the line affected by the attribute. The cursor stays in the same character position when the attribute changes. However, if the attribute would move the cursor past the right margin, the cursor stops at the right margin. When you move lines on the screen by scrolling, the attribute moves with the line. You select line attributes by using the following escape sequences.

NOTE

If you erase an entire line by using the erase in display sequence, the line attribute changes to single-height and single-width.

Double-Height Line

Top Half:	Bottom Half:
ESC # 3	ESC # 4
033 043 063	033 043 064

This sequence makes the line with the cursor the top or bottom half of a double-height, double-width line. Sequences work in pairs on adjacent lines. The same character must be used on both lines to form full characters. If the line was single-width, single-height, all characters to the right of center are lost.

Select Single-Width Line

ESC # 5
033 043 065

This sequence makes the line with the cursor single-width, single-height. This is the line attribute for all new lines on screen.

Select Double-Width Line

```
ESC # 6  
033 043 066
```

Makes the line with the cursor double-width, single-height. If the line was single-width, single-height, all characters to the right of center screen are lost.

Erasing

Erasing removes characters from the screen without affecting other characters on the screen. Erased characters are lost. The cursor position does not change when erasing characters or lines.

If you erase a line by using the erase in display sequence, the line attribute becomes single-height, single-width. If you erase a line by using the erase in line sequence, the line attribute is not affected.

Erasing a character also erases any character attribute of the character. You erase characters by using the following sequences.

Erase in Line

```
ESC [ K 0 ESC [ O K  
033 133 113 033 133 060 113
```

This sequence erases from cursor to end of line, including cursor position.

Erase from Beginning of Line

```
ESC [ 1 K  
033 133 061 113
```

This sequence erases from beginning of the line to cursor, including cursor position.

Erase Complete Line

```
ESC [ 2 K  
033 133 062 113
```

This sequence erases complete line.

Erase in Display

```
ESC [ J or ESC [ 0 J  
033 133 112 033 133 060 112
```

This sequence erases complete line from cursor to end of screen, including cursor position.

Erase Display from Beginning of Screen

```
ESC [ 1 J  
033 133 061 112
```

This display erases from beginning of screen to cursor, including cursor position.

Erase Complete Display

```
ESC [ 2 J  
033 133 062 112
```

This sequence erases all lines and changes them to single-width. Cursor does not move.

Computer Editing

Editing allows the computer to insert or delete characters and lines of characters at the cursor position. The cursor position does not change when inserting or deleting lines. You delete characters or insert and delete lines by using the following control sequences.

Delete Character

```
ESC [ Pn P  
033 133 *** 120
```

This sequence deletes Pn characters, starting with character at cursor position. When a character is deleted, all characters to the right of cursor move left. This creates a space character at right margin. This character has all attributes off.

Insert Line

```
ESC [ Pn L  
033 133 *** 114
```

This sequence inserts Pn lines at line with cursor. Lines displayed below cursor move down. Lines moved past the bottom margin are lost. This sequence is ignored when cursor is outside the scrolling region.

Delete Line

```
ESC [ Pn M  
033 133 *** 115
```

This sequence deletes Pn lines starting at line with cursor. As lines are deleted, lines displayed below cursor move up. Lines added to bottom of screen have spaces with same character attributes as last line moved up. This sequence is ignored when cursor is outside the scrolling region.

Inserting and Replacing Characters

The computer displays received characters at the cursor position. This mode determines how the computer adds characters to the screen. Insert mode displays the character and moves previously displayed characters to the right. Replace mode adds characters by replacing the character at the cursor position. You select insertion-replacement mode by using the following control sequences.

Set Insertion-Replacement Mode

```
ESC [ 4 h  
033 133 064 150
```

This sequence selects insert mode. New display characters move old display characters to the right. Characters moved past the right margin are lost.

Reset Insertion-Replacement Mode

```
ESC [ 4 I  
033 133 064 154
```

This sequence selects replace mode. New display characters replace old display characters at the cursor position. The old character is erased.

Printing in Terminal Mode

The Rainbow computer has a serial printer interface for local printing. The host computer can select all print operations by using control sequences. You can select only two of the print operations from the keyboard, auto-print and print screen.

When you print characters from the screen, the Rainbow computer and printer tab stops are ignored. Print characters are spaced with the space (SP, octal 040) character. The computer transmits a carriage return (CR, octal 015) and line feed (LF, octal 012) after the last printable character of a line, but does not transmit a space character. A line of double-height characters prints as two identical lines of single-width characters. Double-width characters print as single-width characters on a single line.

Before you select a print operation, check the printer status by using the printer status report in ANSI mode. Do not select a print operation if the serial printer is not ready to print. You select print operations by using the following control sequences.

Copy Media (Auto Print ON)

```
ESC [ ? 5 i  
033 133 077 065 151
```

This sequence turns on auto-print. A display line prints after you move cursor off the line, using a line feed, form feed, or vertical tab (also transmitted to printer).

The line also prints during an auto-wrap. Auto-wrap lines end with a CR,LF.

Copy Media (Auto Print Off)

```
ESC [ ? 4 i  
033 133 077 064 151
```

This sequence turns off auto-print.

NOTE

Printer controller has a higher priority than auto-print. Therefore, you can select printer controller and print characters during auto-print.

Copy Media (Printer Controller On)

```
ESC [ 5 i  
033 133 065 151
```

This sequence turns on printer controller. The computer transmits received characters to printer without displaying them. The computer does not insert or delete spaces, provide line delimiters, or select the correct printer character set.

Copy Media (Printer Controller Off)

```
ESC [ 4 i  
033 133 064 151
```

This sequence turns off printer controller. Always move printhead to left margin before turning off printer controller.

Copy Media (Print Cursor Line)

```
ESC [ ? 1 i  
033 133 077 061 151
```

This sequence prints display line with cursor. Cursor position does not change. Print cursor line ends when the line prints.

Copy Media (Print Screen)

```
ESC [ i or ESC [ 0 i  
033 133 151 033 133 060 151
```

This sequence prints the screen. Printer extent selects full screen or scrolling region to print. Select scrolling region by using set top and bottom margins sequence. Print screen ends when screen prints.

Printer Extent in Terminal Mode

This mode selects the full screen or the scrolling region to print during a print screen. You select printer extent mode by using the following sequences.

Set Printer Extent Mode

```
ESC [ ? 1 9 h  
033 133 077 061 071 150
```

This sequence selects the full screen to print during a print screen.

Reset Printer Extent Mode

```
ESC [ ? 1 9 l  
033 133 077 061 071 154
```

This sequence selects the scrolling region to print during a print screen.

Print Termination Character in Terminal Mode

This mode determines if the computer should transmit a print termination character after a print screen. The form feed (octal, 014) control character serves as the print termination character. You select printer form feed mode by using the following control sequences.

Set Termination Character

```
ESC [ ? 1 B h  
033 133 077 061 070 150
```

This sequence selects form feed as print termination character. The computer transmits this character to the printer after each print screen.

Reset Termination Character

```
ESC [ ? 1 B l  
033 133 077 061 070 154
```

This sequence selects no termination character.

Reports

The Rainbow computer transmits reports in response to escape sequence requests. Reports determine computer emulation type and status, and cursor position. The report requests and responses are as follows.

Request Device Status Report

```
ESC [ 5 n  
033 133 065 156
```

Computer requests a status report (using a Device Status Report sequence).

The computer response is as follows:

```
ESC [ 0 n
033 133 060 156
```

which means, "Ready, no malfunctions detected."

The next four codes are other computer responses that can occur and apply to terminal only.

```
ESC [ ? 1 5 n
033 133 077 061 065 156
```

Computer requests a printer status report. The computer checks the status of the printer. This report should be requested before any print operation.

```
ESC [ ? 1 3 n
033 133 077 061 063 156
```

Printer is not connected to computer. The ready signal of the printer has not been on since the computer was turned on.

```
ESC [ ? 1 1 n
033 133 077 061 061 156
```

Printer is not ready to print. The ready signal was on, but is now off.

```
ESC [ ? 1 0 n
033 133 077 061 060 156
```

Printer ready to print. The ready signal is on.

Glossary

ANSI

American National Standards Institute, 1430 Broadway, New York, N. Y. 10018. The Rainbow computer responds to certain control functions standardized by ANSI.

Answerback message

A short message of up to 20 characters that the Rainbow computer transmits upon receipt of an enquiry (ENQ) control character; generated by a **Ctrl/Break** and sent to a remote computer or (optionally) upon first starting communications in terminal mode.

Arbitration

A circuit in the Rainbow computer that decides which event has priority.

ASCII

American Standard Code for Information Interchange, in which each character is represented by a 7- or 8-bit code; included are numbers, letters, punctuation, and special control characters.

Asymmetrical

A communications protocol in the Rainbow computer that uses the secondary channel of a half-duplex modem to provide full-duplex operation. (The modem requires a special cable.)

Asynchronous

A communications method in which the data has its own synchronizing information in start and stop signals.

Attribute

A characteristic assigned to a character or a word, such as boldface, underlined, or blinking.

Auto-Answerback

A feature in the Rainbow computer that allows it to send its answerback message to a remote computer when communication is established between them.

Auto-Screen Blank

A feature in the Rainbow computer that turns off the display on the monitor after 30 minutes, leaving only a phantom blinking cursor.

Auto-Wrap

A feature in the Rainbow computer that prevents characters from printing over the last character on a line; instead, they continue printing on the next line.

Auto-XON/XOFF

A feature in the Rainbow computer that automatically synchronizes it to a remote computer so as not to lose data.

Baud rate

The speed at which data bits are transmitted; for example, bits per second.

Bell System-type modem

A communications data set that translates computer signals to standard telephone transmission signals, and vice versa.

Binary

Two-valued arithmetic or logic, using values 1 and 0. All computer programs use the binary form.

Bit

A binary digit; the smallest unit of information in a binary form, represented as either a 1 or a 0.

Block diagram

A simplified drawing that uses boxes and interconnecting lines to represent the components of a system and their relationships.

Boot (Bootstrap)

1) A small program executed when the computer is turned on whose purpose is to load and start a larger program or the operating system. 2) To start such a program.

Break

1) To open. 2) A signal to stop transmission. 3) A space (0) on the transmit data line if transmission is enabled. 4) The key used to generate such a signal.

Buffer

A storage area meant to temporarily hold data being transferred between two devices.

Bug

An instruction or sequence of instructions in a program that causes unexpected results.

Bus

A conductor through which signals are transmitted between a source and a destination.

Byte

One character position; eight bits of binary data.

CCITT

Comite Consultatif International Telegraphique et Telephoniques (International Telegraph and Telephone Consultative Committee), which sets international communications standards.

Channel

A path for electrical transmission between two points.

Character

A single letter, number, or symbol of information.

Character set

One of several groups of characters that can be generated by a keyboard.

Command

An instruction to a computer program, entered by typing on the keyboard.

Contention

A conflict between the two processors in the Rainbow computer over a signal's availability.

Control function

An action that affects the processing, transmission, or interpretation of data.

Control (Ctrl)

The key used to start a control function.

Controller

An electronic unit that acts as a link between the processor and a peripheral device.

CRC

1) Cyclic redundancy check for errors. 2) The circuit that performs this check.

Cursor

The blinking marker on the monitor that indicates where the next character you type will be positioned.

Data

A general term for information (numbers, letters, and symbols), stored, for example, on a diskette.

Default

The value of a selection assumed by the computer when a specific value is not supplied by the user.

Delimiter

A character that terminates a character string or message, or separates it from surrounding text.

Diagnostic program

A program that detects and isolates malfunctions.

Disk

A platter on which data is recorded magnetically. It features random access and faster access time than magnetic tape.

Diskette

A flexible, removable, magnetic disk; also known as a floppy disk.

Diskette drive

A peripheral device that reads and writes on a disk or diskette.

Duplex

In communications, simultaneous, two-way, independent transmission in both directions; also called full-duplex.

EIA

1) Electronic Industry Association, 2001 Eye Street N.W., Washington, D.C. 20006. 2) A communications standard set by the EIA. 3) A signal that conforms to EIA standards.

8088 processor

A single-chip, 16-bit, parallel, central processing unit manufactured by Intel Corporation.

Emulation

A Rainbow feature that enables control functions similar to those of the VT52 DECscope or those that agree with current ANSI standards.

EOT

End-of-transmission control character, created by typing `Ctrl/D`

Escape (ESC)

The code that provides supplementary characters or commands to the computer when sent before such characters or commands.

FCC

Federal Communications Commission, Washington, D.C.

FDXA

A full-duplex communications protocol that does not use modem control signals.

FDXB

A full-duplex communications protocol that uses modem control signals.

FDXC

A full-duplex communications protocol that uses modem control signals on a half-duplex modem; requires a special cable.

Firmware

A program of instructions that is in read-only memory (ROM) so it will not be changed. The Rainbow computer's firmware includes a selftest program that runs when you turn the computer on and displays the Main System Menu.

Floppy disk

A diskette.

Formatted diskette

A diskette that has its data track pattern already recorded on its surface. The Rainbow computer uses diskettes that are formatted at the factory.

Form feed

A nonprinting character that causes a printer to advance its paper to the beginning of the next page.

Full-duplex

A communications method that allows transmit and receive data at the same time.

Hard disk

A rigid magnetic disk used to store data.

Hardware

Physical computer equipment; mechanical, electrical, or electronic devices.

Hertz (Hz)

A unit of frequency equal to one cycle per second.

Index

- 1) To move the cursor down to the same character position on the next line.
- 2) The small hole in the diskette that marks the beginning of the recorded tracks.

Interrupt

- 1) To break the normal operation of a program being executed.
- 2) The signal that causes such a break.

Key

A single button on the keyboard that, when pressed, sends a letter, number, symbol, or function code to the keyboard's electronic circuitry.

Keyboard

The typing device that causes characters and commands to be generated when its keys are pressed.

Keyclick

An audible sound made by the tone generator inside the keyboard when a key is pressed. In the Rainbow computer the keyclick volume is adjustable in Set-Up.

Lead screw

The screw that guides the read/write heads of the RX50 dual-diskette drive to the correct track on a diskette.

Load

To insert a diskette into the diskette drive and close its door.

Main memory

The main storage area in a computer from which instructions are taken and executed.

Mark state

The presence of a signal, or logical 1 condition, on the communications line.

Mass storage medium

A product, such as a diskette, on which large amounts of data can be stored for ready access by a processor.

Menu

A list of services or functions displayed on the monitor from which you select one for the computer to do.

Mode

A state, such as line or local mode, or method of operation, such as terminal mode.

Modem

A telephone modulator-demodulator; a device that modulates signals for transmission over communications lines and demodulates them for reception.

Modulation

The process of changing some feature (amplitude, frequency, or phase) of a carrier signal to transmit the computer's data signals.

Monitor

1) The device that contains the video screen. 2) The video screen itself.

Monochromatic

Having only one color.

New line mode

A feature in the Rainbow computer that, when in effect, causes the cursor to move to the beginning of the next line when the **Return** key is pressed.

Parameter

1) A variable that you give a specific value in order to set a feature of the Rainbow computer. 2) A selection in Set-Up.

Parity

1) A method of checking for correct data that involves counting the 1 bits in each character's data pattern, and then making the sum either even or odd. 2) The choice in Set-Up for the method of checking parity, whether even, odd, mark, space, or no parity.

Peripheral device

An active device of a computer system, such as a diskette drive or a printer, that extends the system's capacity or functionality.

Port

A connector on the back of the system unit that allows you to connect a peripheral device to the computer.

Processor

The functional part of the computer that uses instructions to perform computation or manipulation of data. The 8088 and the Z80A processor chips in the Rainbow computer are examples.

Protocol

The format the computer uses to transmit and receive communications signals.

RAM

Random-access memory; a computer's main memory to which data is written and from which data is read. This memory can be expanded in the Rainbow computer by adding the memory extension option.

RS-232-C

EIA standard for communications equipment. Off or mark signals can be -3 V to -25 V ; on or space signals can be $+3\text{ V}$ to $+25\text{ V}$.

RS-423

EIA standard for digital interface circuits. Signals for a binary 1 state can be -4 V to -6 V ; signals for a binary 0 state can be $+4\text{ V}$ to $+6\text{ V}$.

ROM

1) Read-only memory; the memory in the Rainbow computer that contains the instructions for the power-up and reset sequences, the selftest, and the program that interprets the keyboard's keys. 2) Firmware.

Scratch diskette

A diskette used for temporary storage of data. It may contain data you do not care to save, or be a blank, formatted diskette.

Screen width

1) The maximum number of characters that can be displayed across the monitor on one line. 2) The setting in Set-Up that allows you to select 80 or 132 columns on the monitor.

Secondary channel

The communications line for control signals on a half-duplex modem.

Sector

One-tenth of a track on a diskette; it holds 512 data characters.

Serial transmission

A method of transferring data in which the bits of the characters are sent sequentially on a single path.

Set-Up

The state of the Rainbow computer that allows you to change the settings of its variable features.

Space

The absence of a signal on the communications line; a logical 0 condition.

Specifications

The physical dimensions and functional features of a product.

Stop bit(s)

One or two pulses at the end of a character's data pattern that signal(s) the end of that pattern.

Synchronization

1) Operation in exact coincidence in time or rate. 2) Timing.

Synchronous

1) Having identical time periods. 2) Pertaining to a communications format in which each data character uses the same time period. The data, including blank time, is controlled by an external clock device or modem.

System

A combination of hardware and software that performs specific processing operations.

System module

The main circuit board where the processors and main memory reside.

System unit

The enclosure that holds the system module and the disk drives.

Terminal mode

1) An operational mode in the Rainbow computer that allows it to act like a terminal, such as a VT102 video terminal. 2) Selection T on the Main System Menu.

Track

A path on a diskette that holds data. There are 80 tracks on each diskette.

Troubleshooting

Isolating a problem to a specific cause.

VT52

1) The VT52 DECscope; a video terminal manufactured by Digital Equipment Corporation. 2) A Set-Up feature in the Rainbow computer that allows the computer to use control functions similar to those of the VT52 DECscope.

XON/XOFF

1) The control characters that synchronize the Rainbow computer to a remote computer so that data transmitted between them is not lost. XON starts data transmission, XOFF stops it. 2) The Set-Up feature that enables these characters automatically. (See Auto-XON/XOFF.)

Z80A processor

A single-chip, 8-bit, parallel central processing unit manufactured by Zilog, Inc.

Index

A

ANSI (American National Standards Institute), 35
ANSI/VT52, 33, 35
Answerback message, 42
ASCII, 37
Asymmetrical protocol, 68, 70
Auto-answerback
 enabling features, 33, 40
 entering message, 42
Auto-boot, 49, 50, 51
Auto-screen blank, 33, 37, 38
Auto-wrap, 33, 36
Auto-XON/XOFF
 role in communication, 39, 70
 selection, 33, 39

B

Baud rate
 communication, 44, 46, 73, 74
 printer, 47, 57
Break, 19, 33, 38, 40, 44, 67, 68, 69, 71

C

CCITT, 58, 71–74
Character codes, 22, 33, 42, Appendix F
Color monitor, Appendix G
 connection to a remote
 computer, 65, 66
COMM connector
 location, 7, 8, 11
 loopback plug, Appendix C
 signal and pin assignments, 72–74
Compose character key, 4, 19, 20, 21, 22
Compose character sequences, 20, 21, Appendix E
Control functions, Appendix H
Copying onto a diskette, 83
Correspondence/Data processing
 keyboard, 33, 34
Ctrl key, 19
Cursor
 control keys, 15–17
 phantom, 37, 38
 selection, 33, 35

D

Data Terminal Ready (DTR), 11, 58, 68, 69, 71, 74
Default, 29, 32, 37
Diagnostic
 add new diagnostic to diskette, 83, 84
 messages, Appendix B
 tests, 77
Disconnect
 character use enable, 33, 40
 delay, 33, 41
Diskette diagnostic test
 error messages, Appendix B
 extended test, 85
 individual test menu, 84, 87
 install new diagnostic, 83, 84
 keyboard test, 87, 88
 loading the diskette, 83
 printer confidence test, 87, 88
 test computer, 84, 85
 test drives A and B, 83, 84
 video alignment pattern, 87, 88
 video controller test, 87, 88
Dual-diskette drive
 description, 12
 installing protective card in, 12, 13
 removal, 7
 specifications, Appendix A

E

8088 processor, 8, 10
Editing keys, 16, 17
Emulation VT52/ANSI, 33, 35
Environment, Appendix A
Escape sequences,
(see Control functions)

F

FCC, copyright page, 11, 54
FDXA
 connect conditions, 68
 defined, 68
 disconnect conditions, 68
 selection, 46
FDXB
 connect conditions, 69
 defined, 68, 69
 disconnect conditions, 69
 selection, 46
FDXC
 connect conditions, 70
 defined, 68, 70
 disconnect conditions, 70
 selection, 46
Full-duplex, 46, 67-70
Function key, 17, 18, 19

G

Graphics option, 8, 10, Appendix G

H

Hard disk drive, 8, 10, 12, 49,
Appendix G
Help key, 28, Appendix B
Hold screen, 19, 21, 22

K

Keyboard
 features, 15-23
 international, Appendix D
 label strip, 16, Appendix D
 lights, 4, 21, 22
Keyclick
 off and on, 33, 36
 volume adjustment, 48, 49

L

LA50 Personal Printer, 11, 46, 53, 54
LA100 Letterprinter 100, 11, 46, 53, 54
Language selection, 23
Light display, 8, 79, Appendix B
Local and line modes, 30
Local echo, 33, 38
Lock, 16, 21, 22
Lock mode, 22, 33, 41
LQP02 Letter-Quality
Printer, 11, 46, 53, 54

M

Manuals
 reference, Appendix C
 ordering, Appendix C
Margin bell
 changing volume, 48, 49
 selecting, 33, 36
Memory option, 8, 10, Appendix G
Memory size, 8, 10, 27
Messages, Appendix B
Miscellaneous major heading, 48
Modem
 changing data bits and parity, 44, 45
 connection, 62–65
 defined, 11
 full-duplex, 68–70
 half-duplex, 68–70
 protocol, 68–70
 setting receive baud rate, 45, 46
 setting transmit baud rate, 44, 45
 stop bits, 33, 39
Monitor
 color, Appendix G
 cleaning, 3
 Rainbow, 3

N

NRC (National Replacement
Character codes), 22, Appendix F
New line mode, 33, 37
Numeric keypad keys, 17, 18

O

Options, 8, 10, Appendix G

P

Parameter Settings major heading, 31
Parity
 changing, 44, 45
 received character, 33, 40
Parts list, Appendix C
PF1–PF4 keys, 18
Power Set-Up feature (50/60 Hz), 33, 37
Power supply, Appendix A
Printer
 connector signals, 58
 data bits and parity, 45, 47, 56, 57
 transmit and receive
 speed, 47, 48, 56, 57
Print extent, 33, 39
Print screen key, 19, 59, 60
Print termination character, 33, 39
Protective card, 12, 13

R

Received character parity, 33, 40
Reset, 51
RLSD
(receive line signal detector), 69, 73
RS-232-C standard, 58, 71
RS-423 standard, 58, 71
RX50 controller module, 9, 12
RX50 dual-disk drive, 12

S

Screen width, 33, 35
Scroll
 jump/smooth, 33, 34
 rate, 48, 49
 region, 39
Selftest
 messages, Appendix B
 selection, 80, 81
Set-Up
 auto-answerback, 33, 40, 42, 43
 auto-boot, 49 50
 auto-repeat, 33, 36
 auto-screen blank, 33, 37, 38
 auto-wrap, 33, 36
 auto-XON/XOFF, 33, 39
 bell volume, 48, 49
 character codes, 33, 42
 correspondence/data
 processing, 33, 34
 cursor, 33, 35
 default character set, 33, 37
 default values, 29, 33
 disconnect character use, 33, 40
 disconnect delay, 33, 41
 emulation, 33, 35
 help, 28
 key, 19, 26
 keyboard language, 23, 33, 42
 keyclick, 33, 36
 keyclick volume, 48, 49
 language, 23, 42
 local echo, 33, 38
 local and line, 30
 lock mode, 33, 41
 margin bell, 33, 36
 miscellaneous, 48, 49
 modem, 44
 modem stop bits, 33, 39
 new line mode, 33, 37
 parameter settings, 31–42

power, 33, 37
printer, 46, 47, 56, 57
print extent, 33, 39
print termination character, 33, 39
recall values, 50
receive character parity, 33, 40
save values, 50
screen background, 33, 36
screen width, 33, 35
scroll, 33, 34
scroll rate, 48, 49
tabs, 29, 30, 31
transmit break, 33, 38
Specifications, Appendix A
Stop bits, 39
System module, 1, 8, 9
System reset, 51
System unit, 1, 6, 54, 62, 63, 79

T

Terminal mode, 74
Testing
 diskette diagnostic, 83–89
 internal diagnostic, 77–82
 messages, Appendix B
Translation, (7-, 8-bit), Appendix F
Transmit break, 33, 38
Troubleshooting, 91–93

W

Wait light, 21, 22
Winchester disk (see hard disk drive)

X

XON/XOFF (see Auto-XON/XOFF)

Z

Z80A processor, 8, 10



NOTICE

FOR USERS OF THE RAINBOW COMPUTER

Certain features of the Rainbow computer must remain at their factory settings so that you can use the software that comes with the computer. You can change these features when you use the Rainbow computer as a terminal; but, you must change them back to their factory settings, shown in the table below, when you use the Rainbow as a personal computer. These features are explained in the *Rainbow™ Owner's Manual* in Chapter 3, Selecting Computer Features Using Set-Up.

Features	Selection	Factory Setting
Emulation (ANSI/VT52)	ANSI	1
Auto-wrap	Off	0
New line mode	LF (Line Feed)	0