

EK-KCRSC-FS-002

Remote Services Console

Field Service Manual

Digital Field Service Engineering
Stow, Massachusetts

First Edition March 1986
Second Edition July 1987

Copyright © 1986 and 1987
by Digital Equipment Corporation
All rights reserved

The reproduction of this material, in part or whole, is strictly prohibited. For copy information, contact the Educational Services Department, Digital Equipment Corporation, Maynard, Massachusetts 01754.

The information in this document is subject to change without notice. Digital Equipment Corporation assumes no responsibility for any errors that may appear in this manual.

Printed in U.S.A.

The following are trademarks of
Digital Equipment Corporation,
Maynard, Massachusetts.

digital [™]	DECwriter	RSX
DEC	DIBOL	UNIBUS
DECmate	MASSBUS	VAX
DECnet	PDP	VMS
DECsystem-10	Professional	VT
DECSYSTEM-20	Rainbow	Work Processor
DECUS	RSTS	

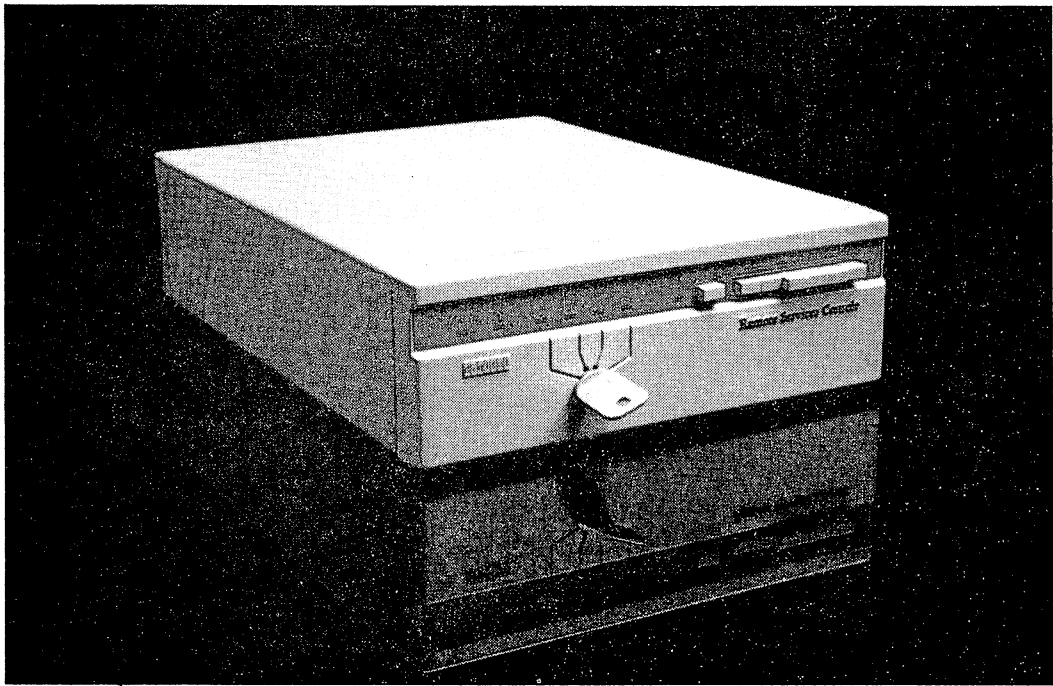

CONTENTS

INTRODUCTION

Scope	v
RSC Overview	v
Certifications	vi
Related Documents	vii

CHAPTER 1 INSTALLATION

1.0	Introduction	1-1
1.1	Site Preparation	1-1
1.1.1	Telephone Line	1-1
1.1.2	Modem	1-1
1.1.3	CPU Communications Port	1-2
1.1.4	AC Power	1-2
1.1.5	Console Terminal and Comm Port Cables	1-3
1.1.6	Accessibility	1-3
1.2	Installation Procedure	1-3
1.3	Removing the RSC Unit	1-20

CHAPTER 2 OPERATION

2.1	Introduction	2-1
2.2	Summary of Operation	2-1
2.3	POWER Indicator	2-9
2.4	FAULT Indicator	2-9
2.5	Data Rate Switches	2-10
2.6	Keyswitch	2-10
2.6.1	REMOTE	2-11
2.6.2	LOCKOUT	2-11
2.6.3	USER PORT	2-12
2.6.4	REMOTE USER	2-12
2.7	Console Terminal Messages	2-12
2.8	Local Copy Switch	2-13

CHAPTER 3 TROUBLESHOOTING

3.1	Introduction	3-1
3.2	Troubleshooting Procedures	3-1
3.3	Cable Test and RSC Bypass	3-1
3.4	Power-up Test	3-2
3.5	USER PORT Test	3-3
3.6	Telephone Line and Modem Test	3-3
3.7	REMOTE USER Test	3-3
3.8	REMOTE Test	3-4

APPENDIX A USER GUIDE

INDEX

TABLES

2-1	Generic Systems Operator Information	2-2
2-2	VAXcluster Operator Information	2-3
2-3	Local VAX/PC38N Console Operator Information	2-4
2-4	Commands Used by the Remote Station (Host)	2-5
2-5	Other Switches and Indicators	2-9
3-1	Troubleshooting Chart	3-5

FIGURES

1-1	Voltage Select Switch and Fuses	1-4
1-2	Language-Specific Label Installation	1-5
1-3	Front Panel Switch Locations	1-6
1-4	Generic RSC Installation Overview	1-8
1-5	VAX/PC38N RSC Installation Overview	1-9
1-6	VAXcluster RSC Installation Overview	1-10
1-7	RSC Cable Configuration Plan	1-12
1-8	EIA Cable Connectors	1-14
1-9	Data Rate Switches	1-15
1-10	Field Transaction Report	1-24
2-1	Typical Printout For VAX Console "Show Status" ..	2-6
2-2	Keyswitch Positions REMOTE and LOCKOUT	2-7
2-3	Keyswitch Positions USER PORT and REMOTE USER ...	2-8
2-4	Data Rate Switches	2-10
A-1	RSC User Guide	A-2

RELEASE NOTES FOR
REMOTE SERVICES CONSOLE FIELD SERVICE MANUAL
REVISION 002

- o This revision includes ECO changes that resolved the problem of garbled or echoed characters when both the customer and the CSC enabled Local Copy (see page 2-13).
- o To reflect software changes, all references to the (RD) console display message prefix have been changed to (RSC 001).
- o We have added specific installation information for VAX/PC38N systems (VAX with PC38N console) beginning on page 1-17.
- o Software changes that resolved the VAX/PC38N TALK mode problem are reflected in Table 2-4 on page 2-5.
- o Some information about "smart" modems has been added on page 1-2.

INTRODUCTION

SCOPE

This manual provides information for Digital Field Service personnel who install, test, and operate the Remote Services Console option (RSC).

Chapter 1 Installation --- Provides a step-by-step procedure for installing the option. It also gives a procedure for removing it.

Chapter 2 Operation --- Describes switch settings for local and remote operations and tells you what the indicators mean. Most of this information is also included in the Site Management Guide for the customer's use.

Chapter 3 Troubleshooting --- Tells you how to solve problems caused by wrong switch settings, cable connections, and other faults external to the RSC unit. The RSC unit is to be swapped if an internal fault occurs.

RSC OVERVIEW

The Remote Services Console (RSC) is a microprocessor-controlled data path switch. RSC is a Digital Field Service "tool" and is not for sale. It will be used for remote services delivery and offers the following features.

- o Does not require a dedicated modem and telephone line.

A customer may have a communications port application using a modem and telephone line. If so, RSC can share the modem and telephone line for other remote services (including remote diagnosis).

- o Gives remote access to the system communications port using Remote Diagnosis Service Protocol (RDSP).

A remote user can log in to the system through a communications port for any authorized application. RDSP protocol is enabled to ensure data integrity.

- o Switch-controlled LOCKOUT

A customer can set the RSC front panel keyswitch to disable all remote access to the system through the RSC modem port. The key can be removed for additional security.

- o Data rate is selectable by front panel switches.

The RSC interfaces operate with their data rates set to match the data rates of the system console terminal and the modem. If the modem or console terminal data rate is changed, there is no need to open the RSC enclosure. The switches on the front panel set RSC to the matching modem or terminal data rate.

- o 9600 bits per second (b/s) capability

RSC operates at data rates of 300, 1200, 2400, 4800, or 9600 b/s.

- o Easier Troubleshooting

A technician or operator can disconnect cables from the RSC unit and patch them together for testing. There is no need to open system enclosures. This makes it easy to find a cable fault or to temporarily bypass the RSC unit if it fails.

CERTIFICATIONS

The Remote Services Console (MDS01) has received the following certifications.

FCC Class A

VDE Class B - DBP Directive 1046/84

Underwriters Laboratory Listed 708A

IEC 435 Classified

CSA

Australia - C83/7/903A

PTT Approved:

Germany - Number ZA301096U
Belgium
Finland
Japan
Sweden

Bescheinigung des Herstellers/Importeurs

Hiermit wird bescheinigt, daß der/die/das

MDS01 Ferndiagnosegerät

(Gerät. Typ. Bezeichnung)

in Übereinstimmung mit den Bestimmungen der

Postverfügung 1046/84

(Amtsblattverfügung)

funk-entstört ist.

Der Deutschen Bundespost wurde das Inverkehrbringen dieses Gerätes angezeigt und die Berechtigung zur Überprüfung der Serie auf Einhaltung der Bestimmungen eingeräumt.

.....
Name des Herstellers/Importeurs **DIGITAL EQUIPMENT GMBH**
Freischützstraße 91
8000 MÜNCHEN 81
Telefon (089) 95 91-0
Telex 5/215780, Telefax 95911010

All other applicable approvals have been applied for.

RELATED DOCUMENTS

Other remote diagnosis manuals cover, in greater detail, related subjects such as site preparation, general modem information, and working with the Digital Customer Support Center (CSC).

KBD01 Options Technical Manual (EK-KBD01-TM)

KC730 Remote Diagnosis Option
Technical Manual (EK-KC730-TM)

KC780 Family Remote Diagnosis Options
Technical Manual (EK-KC780-TM)

1.0 INTRODUCTION

This chapter provides information needed for an RSC installation. It begins with site preparation, continues with a step-by-step installation procedure, including testing, then tells you how to remove an RSC unit.

NOTE

The RSC unit is to be installed only during the period of system warranty or under the terms and conditions of a maintenance contract. RSC remains the property of Digital; it is not for sale.

1.1 SITE PREPARATION

Before you install the RSC unit, you will have to check for each of the following items.

- o A telephone line
- o A modem
- o The CPU communications port
- o AC power for the RSC unit
- o Console terminal and comm port cables
- o Accessibility
- o For all VAX/PC38N systems (any VAX with a PC380 console) a 17-01337-01 adapter is required.
(See Step 2 of the installation procedure.)

1.1.1 Telephone Line

If there is no telephone line to the system, the customer will have to arrange for one to be installed. It should be, at a minimum, a voice grade line that supports up to 1200 b/s operation. The telephone company may ask the customer to give them certain information about the modem that will be connected to the line. An example of the required information is given in Paragraph 1.1.2.

1.1.2 Modem

The customer is required to supply, and have installed, a modem that is suitable for RSC remote operation. The modem must be RS-232-C compatible, comply with Digital Standard 052, and provide the Automatic Answer feature. All modems manufactured by Digital meet the above criteria.

Note that some "smart" modems are software-controlled and cannot be used because the signals specifically used by RSC (DSR, DTR, CTS, and DCD) are "forced on" or tied high. Also, a modem that has jumpers or switches to change signal options may be used by a customer in a non-compatible configuration. You will want to avoid the use of such a modem because of the problem of changing the configuration each time it is to be used for remote services.

Before the modem is installed, the telephone company may ask the customer to give them information about the modem. For example, the information needed for Digital DF03 or DF112 modems is as follows.

MANUFACTURER	Digital
MODEL	DF03-AA or DF112-AA
FCC REGISTRATION NO.	DF03-AA - A0994Q-69391-DM-R DF112-AA - A0994Q-13634-DM-E
RINGER EQUIVALENCE	DF03-AA - 0.3, Type A DF112-AA - 0.3, Type B
DATA RATE	300/1200 b/s

The RSC modem interface supports data rates of 300 to 9,600 bits per second (b/s). Thus, RSC allows both the customer's CPU comm port and Digital's Remote Services Delivery to operate at speeds up to and including 9600 b/s.

1.1.3 CPU Communications Port

Most customer systems have at least one communications port (DZ, DMF, DMB) being used with a modem and a telephone line. You can connect the port through the RSC unit, sharing the port and the modem for both the customer's operations and remote services.

If the customer has not implemented a CPU comm port, there is no need to do so when RSC is installed. RSC does not need to have a comm port connection, but can support one. A comm port can be implemented easily at any time if the customer wants to time-share the modem.

1.1.4 AC Power

The RSC unit requires an ac receptacle for its power. There is a 120/240 voltage select switch on the RSC rear panel that must be set to the local voltage. The RSC unit should be connected to an AC power receptacle that a) is not switched by the CPU power controller and, b) cannot be switched off accidentally. Even when all or part of the computer system is down, the RSC unit may be required for remote service.

1.1.5 Console Terminal and Comm Port Cables

The RSC external interfaces are EIA, RS-232-C compatible and operate with RS-423 equipment. For control of emissions, the cables used with RSC should be shielded, Digital BC22E or BC22F or equivalent.

1.1.6 Accessibility

The RSC unit must be installed so that it is accessible. The operator must be able to set the keyswitch and data rate switches and see the indicators. If the modem also has front panel data rate switching, the RSC unit and the modem should be close together. The installation procedure helps you use the available cables to put the RSC unit in the most convenient place.

1.2 INSTALLATION PROCEDURE

STEP 1

Make sure that you have prepared the site. See Paragraph 1.1.

STEP 2

Unpack the option kit and make sure you have all the parts and that they are not damaged.

The kit includes the following items.

- 1 RSC Unit
- 1 Power Cord
(factory ships with 120 volt, parallel blade male plug)
- 1 BC22F-10 Cable
- 1 BC22F-25 Cable
- 1 RSC Field Service Manual, EK-KCRSC-FS
- 1 RSC User Guide, EK-KCRSC-UG
- 1 RSC User Guide, EK-KCRSC-SM

- 1 Accessory Kit 70-23715-01 (contains the following items)
 - 1 Language-specific Label Set
 - 1 Fuse Carrier, 12-21126-04
 - 1 Fuse, 12-19283-19, .50A, 5mm.
 - 1 Fuse, 12-19283-16, .25A, 5mm.
 - 2 Keys
 - 1 Field Transaction Report Form, EN-01748-12

VAX/PC38N NOTE

An EIA adapter, part number 17-01337-01 is required for VAX/PC38N installation. The adapter is not shipped with the RSC option. The adapter is shipped with each VAX/PC38N and should be present on-site.

STEP 3

WARNING

ALL RSC units are shipped with the voltage select switch set for 120 volt operation and a 3AG, .5A Slow Blow fuse. Damage may result if the unit is connected to any other power source before Step 3 is completed.

In this step you will prepare the RSC unit for connection to ac power (Figure 1-1).

- o Remove the yellow warning label that covers the ac receptacle.
- o Set the voltage select switch for operation on the local ac voltage supply, 100/120 or 220/240 Vac nominal.
- o For 120V operation, leave the 3AG .5A fuse in place.
- o For 100V operation, remove the 3AG .5A fuse and carrier and insert the .5A, 5mm fuse with the 5mm carrier.
- o For 220/240V operation, remove the 3AG .5A fuse and carrier and insert the .25A, 5mm fuse with the 5mm carrier.

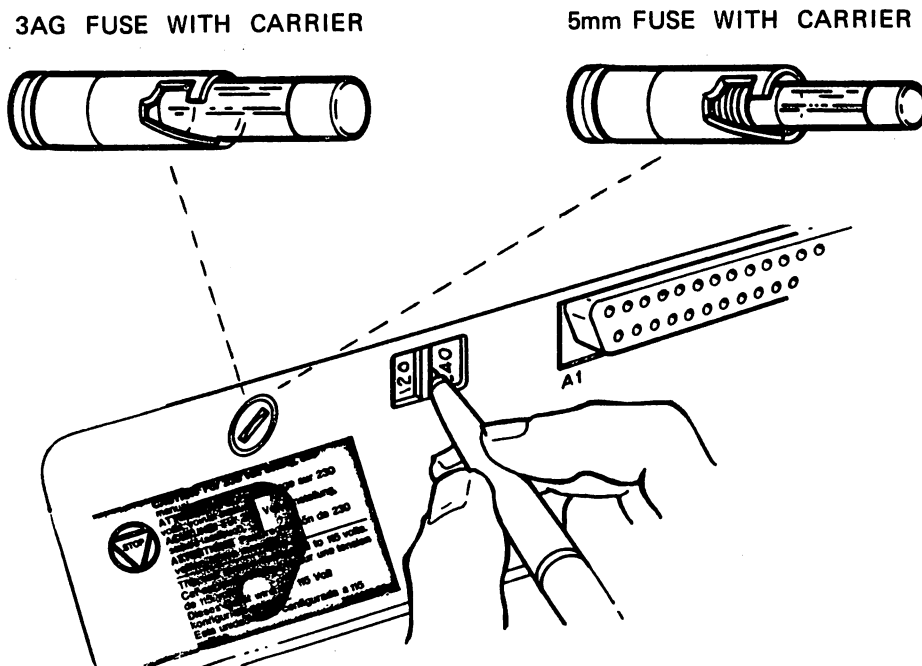

Figure 1-1 Voltage Select Switch and Fuses

STEP 4

Place the RSC unit so it is standing up on its rear panel. Select the applicable local language label from the language-specific label set. Peel the label away from the backing sheet (handle the label by its edges). Align either the right hand or left hand edge of the label within the recessed area on the front of the unit. Guide it gently into position and, when it is correctly aligned, press it down firmly. (See Figure 1-2)

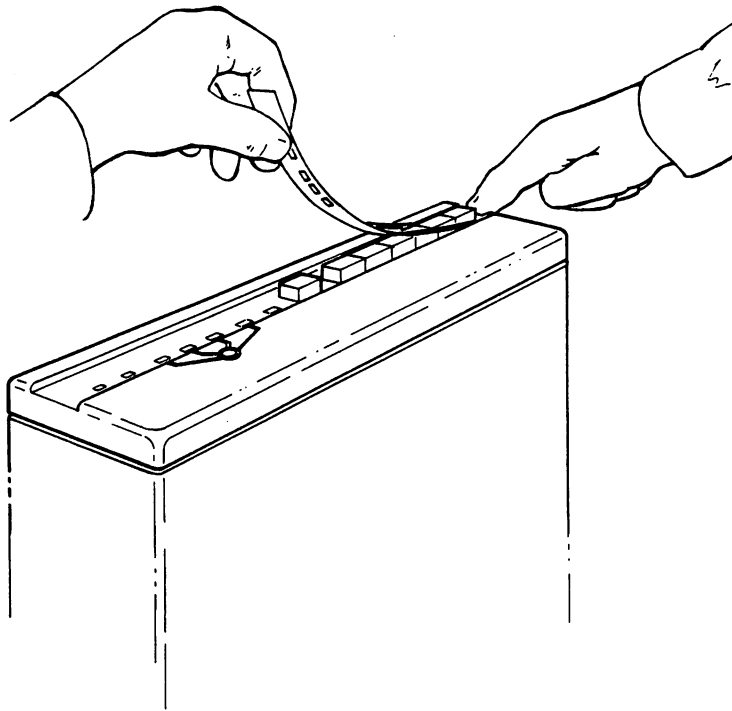

Figure 1-2 Language-Specific Label Installation

STEP 5

In this step you do a preliminary, basic operation test of the RSC unit.

- o Set the RSC keyswitch to REMOTE USER. Figure 1-3 shows the location of the front panel switches.
- o Plug in the ac power cord. (Do not connect any other cables.)
- o The POWER indicator should come on (there is no power switch).
- o The FAULT indicator should come on for about one second (during the power-up self-test), then go off.
- o Test each of the four positions of the keyswitch. Make sure that each corresponding indicator comes on. The REMOTE and REMOTE USER indicators should blink.
- o Press the LOCAL COPY switch in and latch it. Test each of the four positions of the keyswitch. The LOCAL COPY indicator should come on only when the keyswitch is in the REMOTE position.

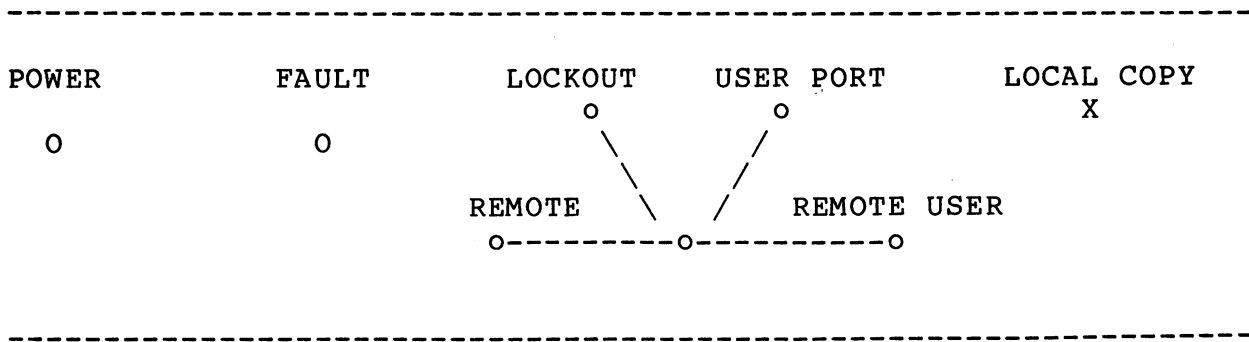

Figure 1-3 Front Panel Switch Locations

STEP 6

Ask the customer to assign an account number and password for the Customer Support Center (CSC) to use. Call the CSC, give them their account number and password, and ask them to schedule a test when you finish the installation.

STEP 7

Arrange with the customer to have use of the system during installation and testing. Figures 1-4, 1-5, and 1-6 show the basic steps involved in an RSC installation. You will not need to shut down the system, but the customer needs to know when you are disconnecting cables and doing tests. For example, disconnecting a console terminal cable while a message is being received could cause a system problem.

Make sure that the console terminal is working correctly and that there are no problems that might interfere with RSC operation or testing. If the customer has a modem and telephone line working on a communications port, test them for correct operation also.

-----+
VAXcluster NOTE

A VAXcluster node may not have a dedicated console terminal.

STEP 8

Before you begin installation, check the lengths of the cables that you will use and make sure that you can put the RSC unit where the customer wants it. Two cables are supplied in the RSC kit and you will also use the following cables that are already at the site.

- o The cable that connects the console terminal to the CPU console terminal port (not on VAX/PC38N). This cable is a BC22D or equivalent (female/female) and will be used to connect the console terminal to the RSC unit in Step 11.

- o If the CPU comm port has been implemented, the cable that connects the modem to the CPU comm port.

-----+
VAX/PC38N NOTE

The VAX\PC38N does not have a traditional console terminal; you will be connecting a cable from RSC to the VAX Console System Remote Port in Step 11.

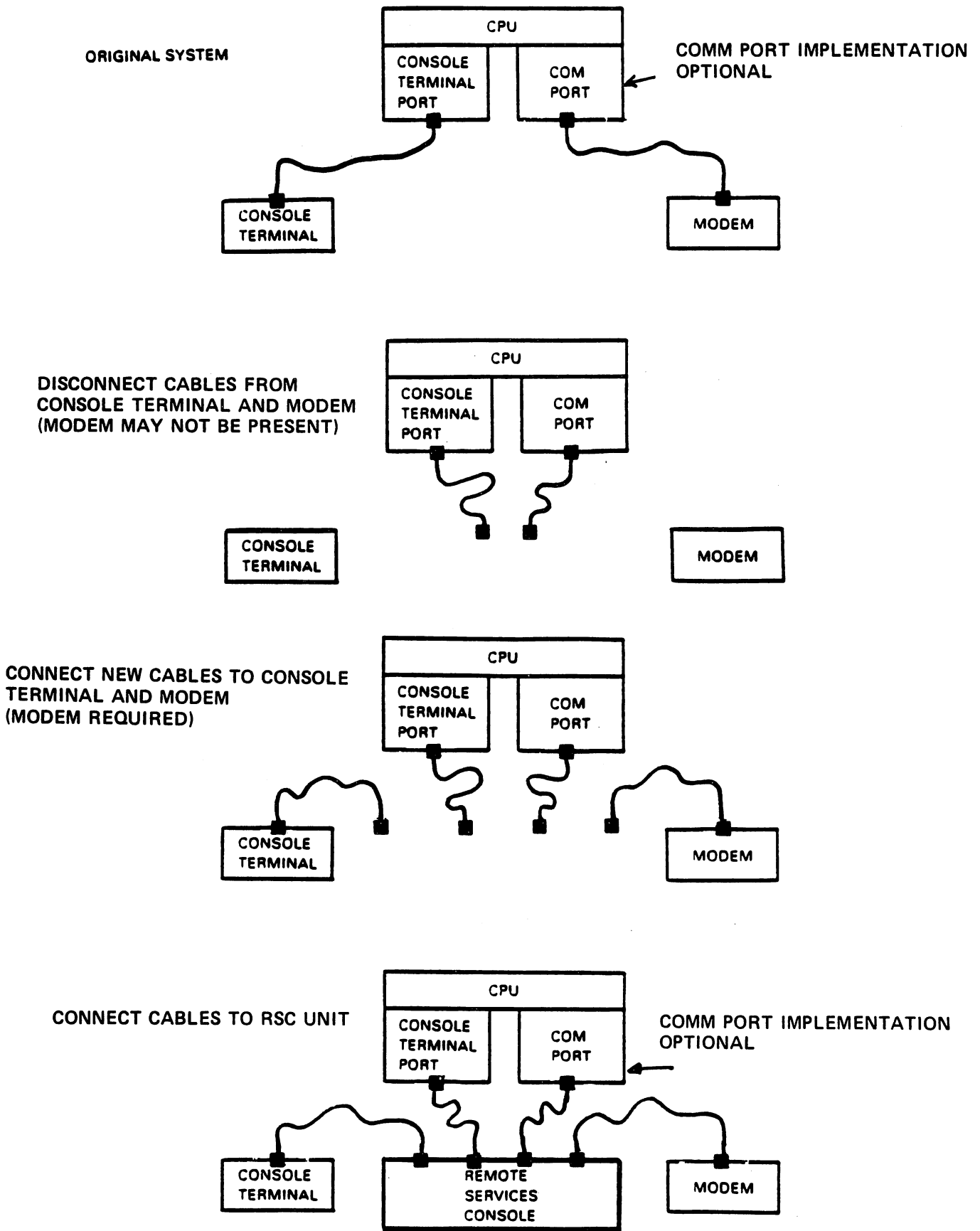

Figure 1-4 Generic RSC Installation Overview

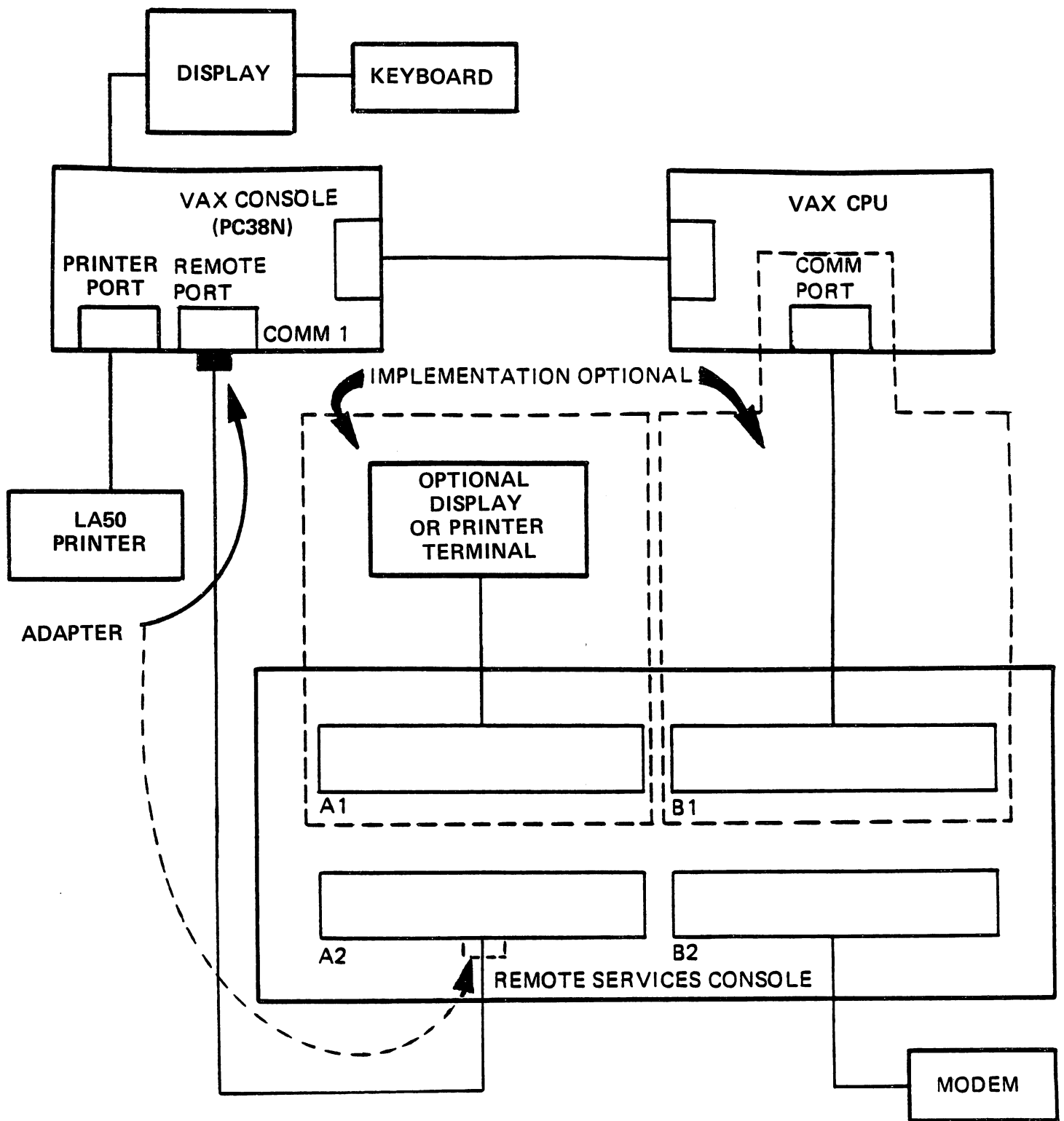

Figure 1-5 VAX/PC38N RSC Installation Overview

THIS PAGE IS RESERVED FOR VAXcluster INFORMATION
WHICH WAS NOT AVAILABLE PRIOR TO THE
PUBLICATION DATE OF THIS MANUAL

Figure 1-6 VAXcluster RSC Installation Overview

You can use Figure 1-7 to plan how to configure the RSC cables. The cables may be of different lengths, but most of them are interchangeable. When you know where the customer wants the RSC unit installed, you can plan where each cable should be used.

CABLE NOTE

1. The cable connecting the local console terminal to the CPU console terminal port will be a BC22D. It is not interchangeable with the other cables being used with RSC, and it must be connected to the CPU console terminal port and RSC connector A2 (in Step 11).

2. The other cables must be BC22E or BC22F or equivalent and they are all interchangeable. These are required because RSC implements full modem control.

STEP 9

Follow your cabling plan in Figure 1-7 when you disconnect the system cables. Your plan should identify the cable connectors you will disconnect and the ones you will not have to disturb.

Disconnect the BC22D cable from the console terminal, leaving it connected to the CPU Console Terminal port (does not apply to VAX/PC38N).

STEP 10

For all systems including VAX/PC38N, if the comm port has been implemented, disconnect the cable that connects the CPU comm port to the modem. You may not need to disconnect both ends of the cable.

+-----+
VAX/PC38N NOTE

If there is a cable connected from the modem to the VAX Console System Remote Port (COMM PORT 1), disconnect it.

Before you begin to move hardware around, you may want to use the space on the facing blank page to sketch out and plan the installation. It can help you decide:

- o Where you will use each available cable;
- o Whether you will need longer cables to be able to put the hardware where the customer wants it;
- o Which cable connectors are already in the right place and won't have to be disturbed.

All systems except VAX/PC38N have a BC22D connecting the CPU Console Terminal Port to the Console Terminal. This cable must remain connected to the CPU Console Terminal Port.

_____ Length _____

Any system MAY have a cable connecting the CPU Comm Port to a Modem.

_____ Length _____

VAX/PC38N Systems MAY have a cable connecting the VAX Console System Remote Port to a modem.

_____ Length _____

(These two cables are supplied in the option kit.)

BC22F-25 Length 25'

BC22F-10 Length 10'

Figure 1-7 RSC Cable Configuration Plan

WORKSHEET FOR USE WITH FIGURE 1-7

STEP 11

Put the RSC unit (and the modem) where you are going to install them. Follow your cabling plan in Figure 1-7 and connect the cables as shown in the table below. Note that the RSC does not require that a CPU comm port be implemented, but if there is one, Digital recommends that it be connected to the RSC. Figure 1-8 shows the locations of the connectors.

SYSTEMS	CONNECT CABLE FROM-	TO RSC CONNECTOR
All Generic Systems	Local Console Terminal	A1
All Generic Systems	CPU Console Terminal Port (BC22D)	A2
All Generic Systems	CPU Comm Port	B1
All Generic Systems	Modem	B2
VAX/PC38N	Hardcopy Terminal *	A1
VAX/PC38N	Console System Remote Port **	A2
VAX/PC38N	CPU Comm Port *	B1
VAX/PC38N	Modem	B2

VAXcluster Information will be added at the next revision.

* Implementation is optional.

** Install adapter 17-01337-01 at the PC38N VAX Console Remote Port. (It can be installed, optionally, at RSC connector A2.)

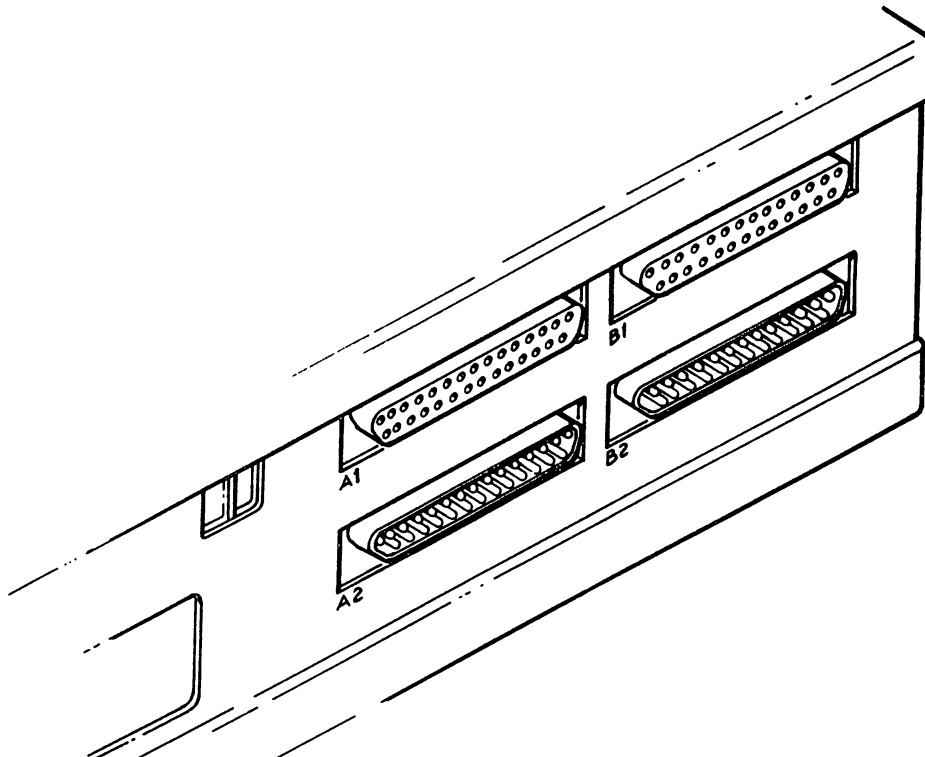

Figure 1-8 EIA Cable Connections

STEP 12

Determine the data rate at which the modem will operate. This will be typically 1200 b/s (but could be 300 b/s) for CSC operations. Set the RSC modem data rate switches (BAUD M) to that rate (see Figure 1-9).

STEP 13

Determine the data rate at which the CPU console terminal is operating (use the SETUP key). Set the RSC terminal data rate switches (BAUD T) to that rate. Note that the local terminal must be set up for 8 Bit, No Parity operation.

VAX/PC38N NOTE

The VAX Console Remote Port is not a traditional console terminal port; it is a modem control port. Set the BAUD T switches to 1200 b/s. You will set the VAX Console Remote Port to 1200 b/s in Step 14.

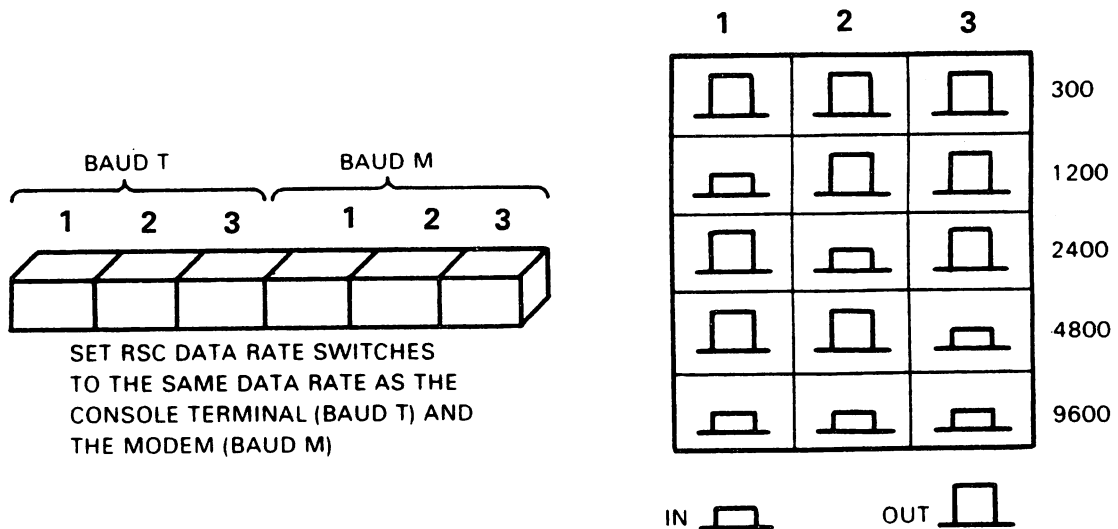

Figure 1-9 Data Rate Switches

NOTE

You have completed the hardware installation and, beginning at Step 14, you will test system operation. Since the VAX/PC38N and generic systems test procedures are so different, the following steps are separated onto opposite pages. A header on each page indicates which system the page is to be used for.

GENERIC SYSTEMS TEST

STEP 14 - GENERIC SYSTEMS TEST

In this step you will test operation of the CPU Console Terminal port.

- o If the CPU has a LOCAL/REMOTE switch, set it to LOCAL.
- o Make sure the modem has power. The modem DTR indicator should come on.
- o Plug in the RSC power cord.
- o Set the RSC keyswitch to REMOTE. The REMOTE indicator should come on, blinking.
- o RSC transmits the message "(RSC 001) REMOTE PORT ENABLED" which should be printed on the console terminal.
- o Use a nearby telephone and dial the number of the telephone line that is connected to the modem.
- o The modem DSR and CAR indicators should come on and you should hear a carrier tone.
- o Within 30 seconds, the modem should time-out and drop the line. You can then hang up the telephone.
- o RSC transmits the message "(RSC 001) CONNECTION LOST" which should be printed on the console terminal.
- o The DSR and CAR indicators should go off but the DTR indicator will remain on. The message "(RSC 001) REMOTE PORT ENABLED" should be printed on the console terminal.

STEP 15 - GENERIC SYSTEMS TEST

In this step you will test the CPU communications port. Note that RSC can support a comm port but does not require one for its operation.

- o Set the RSC keyswitch to REMOTE USER.
- o The REMOTE USER indicator should come on, blinking.
- o Test the console terminal for normal operation by typing on the keyboard.
- o The modem DTR indicator should be on.
- o Use a nearby telephone and dial the number of the telephone line that is connected to the modem.

VAX/PC38N TEST

STEP 14 - VAX/PC38N / RSC PREREQUISITES

In this step you will check to make sure the prerequisites for RSC operation are present.

Check the VAX Console Communications Set-up Line Characteristics Menu and see that both Transmit and Receive speeds are set to match the modem speed and that Connection Type is modem (see the VAX/PC38N Console User Guide).

STEP 15 - VAX/PC38N SET-UP

At this step you will display the VAX Console set-up, check to see if the settings are correct for RSC remote operation, then make any necessary changes.

At the >>> prompt, enter a Show Status command and get the following printout:

```
+-----+
| >>>SH S                                     |
|                                             |
| .....                                     |
| .....                                     |
| Printer ENABLED, ONLINE.  Remote Carrier:ABSENT. |
|                                             |
| Remote                                     |
|   user:ENABLED; console:ENABLED; modem:ENABLED; monitoring:ENABLED |
|                                             |
| Program Mode settings: LOCAL=OPA0      REMOTE=OPA(4 or 5) |
+-----+
```

- o Make sure that the printer (the LA50 connected to the VAX console printer port) is enabled.
- o Make sure that Remote User, Remote Console, Remote Modem, and Remote Monitoring are enabled.
- o Make sure that the Program Mode settings are as shown. You may have to change REMOTE to OPA4 or OPA5 as required for remote access. You can ask the local operator to help or see the VAX Console User Guide for instructions.

GENERIC SYSTEMS TEST

STEP 15 - GENERIC SYSTEMS TEST (Cont)

- o The modem DSR and CAR indicators should come on and you should hear a carrier tone.
- o The REMOTE USER indicator should stop blinking and stay on.
- o Within 30 seconds, the modem should time-out and drop the line. You can then hang up the telephone.
- o The REMOTE USER indicator should begin blinking again.

STEP 16 - GENERIC SYSTEMS TEST

In this step you will test for normal use of the system by the customer.

- o Set the RSC keyswitch to the USER PORT position.
- o The USER PORT indicator should come on.
- o Test the console terminal for normal operation by typing on the keyboard.
- o If the customer has a communications port application that uses the modem and telephone line, ask the local operator to:
 - a. Check system comm port setup to make sure that either "modem" or "modem/perm" is set. If "no modem" is set, the test in b. and c. will fail.
 - b. The modem DTR indicator (if it has one) should be on.
 - c. Test comm port operation (by having a user log into the system through the modem). Log out before continuing to the next step.

STEP 17 - GENERIC SYSTEMS TEST

In this step you will test the RSC LOCKOUT function. When the keyswitch is set to LOCKOUT, RSC does not allow remote access to the system.

- o Set the RSC keyswitch to the LOCKOUT position.
- o The LOCKOUT indicator should come on.
- o Test the console terminal for normal operation by typing on the keyboard.

VAX/PC38N TEST

STEP 16 - VAX CONSOLE PRINTER TEST

In some circumstances the VAX Console printer may be enabled, but may not print.

- o Make sure that PRINTER is ENABLED and enter a Show Status command.
- o If the status report was printed on the LA50, you can skip to Step 17. If it was not, toggle the printer from ON LINE to OFF LINE to ON LINE. This should restore printer operation.
- o Enter another Show Status command and make sure that it is displayed on the VAX Console screen and also printed on the printer.

STEP 17 - VAX/PC38N / RSC PRELIMINARY TEST

In this step you will do a preliminary test of the telephone line and modem before you ask the CSC to do their testing.

- o Make sure the modem has power.
- o Plug in the RSC power cord. The POWER indicator should come on.
- o Set the RSC keyswitch to REMOTE. The REMOTE indicator should come on, blinking.
- o RSC transmits the message "(RSC 001) REMOTE PORT ENABLED" which should be printed on the (optional) hardcopy terminal connected to RSC at A1.
- o The modem DTR indicator should come on.
- o Use a nearby telephone and dial the number of the telephone line that is connected to the modem.
- o The modem DSR and CAR indicators should come on and you should hear a carrier tone.
- o The VAX Console and the LA50 printer should display the message "WARNING. REMOTE CONNECTION ESTABLISHED.
- o Within 30 seconds, the modem should time-out and drop the line. You can then hang up the telephone.

GENERIC SYSTEMS TEST

STEP 17 - GENERIC SYSTEMS TEST (Cont)

- o The modem DTR indicator should be off.
- o Use a nearby telephone and dial the number of the telephone line that is connected to the modem.
- o You should hear a ring signal continuously, but the modem should not respond.
- o After about 20 seconds you can hang up the telephone.

STEP 18 - GENERIC SYSTEMS TEST

Call the CSC and ask them to do remote testing to verify that the RSC installation is working correctly.

Digital ships most modems with option settings that let the CSC connect to RSC. If they find some incompatibility, they may ask you to change option settings.

NOTE

There are no steps 19 through 21 in the Generic Systems Test procedure. Skip now to Step 22 on page 1-23.

VAX/PC38N TEST

STEP 17 - VAX/PC38N / RSC PRELIMINARY TEST (Cont)

- o The message "(RSC 001) CONNECTION LOST" should be printed on the (optional) hardcopy terminal connected to RSC at A1.
- o The DSR and CAR indicators should go off but the DTR indicator should remain on. The message "(RSC 001) REMOTE PORT ENABLED" should be printed on the (optional) hardcopy terminal connected to RSC at A1.
- o The VAX Console and the LA50 printer should display the message "WARNING. REMOTE CONNECTION BROKEN."

STEP 18 - VAX/PC38N / RSC (REMOTE) CSC TEST

Call the CSC and ask them to test system operation. You can watch the VAX Console screen or the LA50 printer as the CSC does the testing. Some of the tests they will do are:

NOTE

Digital ships most modems with option settings that let the CSC connect to RSC. If they find some incompatibility, they may ask you to change option settings.

- o Dial in and make a logical connection. The VAX Console and the LA50 printer should display the message "WARNING. REMOTE CONNECTION ESTABLISHED."
- o Enter the Show Status command and verify that the VAX Console has been set up for RSC operation. If there are configuration errors, the CSC can make the corrections remotely.
- o Enter the Set Terminal Program (SET TERM P) command then, at the Username prompt, log in using the assigned account user name and password.
- o Enter a DIR command for a basic communications test.
- o Read the LOGFILE for OPA0 (SH L at the <<< prompt) to determine that remote port I/O activity is being monitored.
- o Do an RHM (Remote Hardware Monitoring) installation and an RFT (Remote File Transfer).

Note that Digital ships most modems with option settings that let the CSC connect to RSC. If they find some incompatibility, they may ask you to change option settings.

VAX/PC38N TEST

STEP 19 - VAX/PC38N / RSC REMOTE USER TEST

If the VAX/PC38N system has a communications port, you will test it in Steps 19 and 20. Skip to Step 21 if there is no comm port. In this step you will test the RSC Remote User function.

- o Set the RSC Keyswitch to the REMOTE USER position.
- o The CSC will make a connection to the system using DDCMP protocol. (Note that RSC supplies DTR.)
- o The CSC will log in with P I/O access only.
- o They will verify that they can do an RFT then log out.

STEP 20 - VAX/PC38N / RSC USER PORT TEST

In this step you will test the RSC User Port function.

- o Set the RSC Keyswitch to the User Port position.
- o The CSC will make a non-protocol connection to the system. (Note that the comm port software must supply DTR; make sure "modem" or modem/perm" is set).
- o The CSC will log in to the system as a user, verify that they can do an RFT, then log out.

STEP 21 - VAX/PC38N / RSC LOCKOUT TEST

In this step you will test to make sure the RSC does not allow remote access to the system through the RSC's modem port.

- o Set the RSC Keyswitch to the LOCKOUT position.
- o The LOCKOUT indicator should come on.
- o The modem DTR indicator should be off.
- o You can ask the CSC to attempt remote access or you can do it yourself. Use a nearby telephone and dial the number of the telephone line that is connected to the modem.
- o You should hear a ring signal, but the modem should not respond. After about 20 seconds you can hang up the phone.

STEP 22 - ALL SYSTEMS TEST

You can now return control of the system to the local operator.

STEP 23

Give the RSC User Guide, EK-KCRSC-UG, to the appropriate customer representative and explain how the guide is to be used.

Insert the second RSC User Guide, EK-KCRSC-SM into the Site Management Guide binder behind the "R/D" tab.

STEP 24

Ask a customer-authorized representative to sign the Field Transaction Report Form, EN-01748-12. A copy of that form is provided in Figure 1-10.

YOU HAVE COMPLETED THE INSTALLATION



REMOTE SERVICES CONSOLE - FIELD TRANSACTION REPORT

(Use this form to report only one RSC transaction)

CUSTOMER/SYSTEM IDENTIFICATION

Company _____

Address _____

City _____ State _____ Zip Code _____

Remote Services Console used on:

Computer System Type: _____ Serial Number: _____

ACKNOWLEDGEMENT OF INITIAL RSC INSTALLATION

I, the undersigned authorized representative of the company named above, acknowledge receipt of a Remote Services Console (MDS01).

I recognize that this Remote Services Console is proprietary equipment of, and always remains the exclusive property of, Digital Equipment Corporation. I accept this Remote Services Console in confidence and agree not to remove or tamper with any part of it, nor to disclose or make any part of it available to a third party.

I further acknowledge that I will allow Digital full and free access to replace or remove the Remote Services Console and to restore the system to its original configuration upon expiration of the system warranty or termination of the Digital Service Agreement.

MDS01 Serial Number _____ Date _____

ACKNOWLEDGEMENT OF RSC REMOVAL BY DIGITAL

I, the undersigned Digital representative, acknowledge receipt of a Remote Services Console unit removed from the customer system identified above.

MDS01 Serial Number _____ Date _____

ACKNOWLEDGEMENT OF RSC UNIT EXCHANGE

We, the undersigned representatives of Digital and of the company named above, acknowledge an exchange involving two Remote Services Consoles.

MDS01 Removed - Serial Number _____ Date _____

MDS01 Installed - Serial Number _____ Date _____

Digital Representative's Name (Printed) _____

Digital Representative's Signature _____

Customer Representative's Name (Printed) _____

Title _____

Customer's Representative's Signature _____

Figure 1-10 Field Transaction Report

1.3 REMOVING THE RSC UNIT

If you have not done an installation, go back and read all of this chapter so you will know what was done and why.

STEP 1

Arrange with the customer for access to the system. Make sure there are no known problems which the customer might assume were caused by removing RSC. You will be changing I/O cable connections, but you will not need to shut down the system.

NOTE

If the customer's system is running, do not disconnect power to the RSC until you have disconnected the I/O cables. Spurious noise at the console terminal or CPU console port could disturb system operation.

Leave ac power applied to the RSC unit as you do Steps 2 and 3.

STEP 2

Disconnect the cables from RSC connectors A1 and A2. Connect the BC22D cable from the CPU Console Terminal port to the Console Terminal.

STEP 3

Disconnect the cables (if they are present) from RSC connectors B1 and B2. Use a BC22E or BC22F cable to connect the modem to the CPU comm port.

STEP 4

Disconnect the RSC power cord.

STEP 5

Have the customer test the console terminal (or the VAX 8800 console), and communications port (if implemented) for normal operation.

STEP 6

Prepare a Field Transaction Report form, signed both by the customer's representative and yourself. The customer's copy will be a receipt acknowledging that Digital has taken possession of the RSC unit.

STEP 7

Pack the option components in a suitable shipping container.

2.1 INTRODUCTION

This chapter tells you how to use the the RSC for both the customer's normal operation and Digital's remote services delivery. The RSC unit operates continuously and needs no routine maintenance. There are no switches or adjustments inside the enclosure. When the RSC logic is not busy, it runs a self-test program to ensure reliable operation.

2.2 SUMMARY OF OPERATION

This paragraph gives a summary of the steps you take to operate a system with an RSC.

First, four tables summarize operator information such as system set up for:

- o Generic systems such as VAX-11/780, Table 2-1,
- o Table 2-2 will provide VAXcluster systems information,
- o VAX systems with PC38N consoles, Tables 2-3 and 2-4 (and Figure 2-1).

Second, there are two figures that show the logical data paths for each of the RSC modes of operation (Figures 2-2 and 2-3).

Then the paragraphs that follow provide more detailed explanations of the summary steps.

Table 2-1 Generic Systems Operator Information

REMOTE SERVICES CONSOLE (RSC)	GENERIC SYSTEM
<p>POWER indicator must be ON, FAULT indicator must be OFF.</p> <p>Set BAUD M switches to same data rate as the modem.</p>	<p>The local terminal must be set for 8-Bit, No Parity operation.</p> <p>Set BAUD T switches to same data rate as the local console terminal.</p>
<p><u>REMOTE</u> Keyswitch Position</p> <p>REMOTE indicator blinks when the remote station is not logically connected.</p> <p>RSC gives the remote station control of the target system when the local operator sets the RSC keyswitch to REMOTE.</p> <p>RSC Local Copy forces console terminal to print a record of remote I/O activity.</p>	<p>CPU LOCAL/REMOTE keyswitch must be set to LOCAL.</p> <p>Remote station terminal or host system replaces the local console terminal.</p> <p>DDCMP Protocol is enabled to ensure data integrity.</p> <p>Terminal messages tell you about remote station activity and status.</p> <p>RSC disables the CPU Comm Port.</p> <p>When the RSC keyswitch is set to REMOTE, you can boot the system from the local console terminal only when the remote station enables parallel control (GIVE).</p>
<p><u>REMOTE USER</u> Keyswitch Position</p> <p>REMOTE USER indicator blinks when the remote station is not logically connected.</p> <p>RSC can support a comm port, but does not require it.</p>	<p>CPU LOCAL/REMOTE keyswitch must be set to LOCAL.</p> <p>Local console terminal operation is normal.</p> <p>RSC allows remote access to the operating system through the CPU Comm Port with DDCMP protocol.</p>
<p><u>USER PORT</u> Keyswitch Position</p> <p>RSC is transparent. All system operation is normal.</p>	<p>Enable CPU Comm Port software for "Modem on"/"modem perm" if modem dial-in capability is required.</p> <p>System operation is normal.</p>
<p><u>LOCKOUT</u> Keyswitch Position</p> <p>RSC disables all remote access through its modem port.</p>	<p>No remote access through RSC modem port.</p> <p>System operation is normal.</p>

Table 2-2 VAXcluster Operator Information

THIS PAGE IS RESERVED FOR VAXcluster INFORMATION
WHICH WAS NOT AVAILABLE PRIOR TO THE
PUBLICATION DATE OF THIS MANUAL

Table 2-3 Local VAX/PC38N Console Operator Information

REMOTE SERVICES CONSOLE (RSC)	VAX/PC38N SYSTEM
<p>POWER indicator must be ON, FAULT indicator must be OFF.</p> <p>Set BAUD M switches to same data rate as the modem.</p>	<p>Set BAUD T switches to same data rate as the remote port.</p>
<p><u>REMOTE</u> Keyswitch Position</p> <p>REMOTE indicator blinks when the remote station is not logically connected.</p> <p>RSC gives the remote station control of the target system when the local operator enables remote access. DDCMP protocol is enabled to ensure data integrity.</p> <p>RSC Local Copy is redundant with VAX/PC38N if optional print/display terminal is connected to RSC at A1.</p>	<p>Enable Remote User (EN R U) and/or Disable Remote Console (DIS R C) if the remote station is to have only PI/O user mode access. This is the traditional Remote Disable mode.</p> <p>Enable Remote Console (EN R C) enables CI/O and PI/O. Remote station can disable remote console to do RHM as a user (cannot re-enable it remotely).</p> <p>Disable Remote Modem (DIS R M) (RSC controls the modem). Note that the modem is not actually disabled; see VAX Console user documentation.</p> <p>Enable Remote Monitoring (EN R MON) to display remote station I/O activity at the VAX Console.</p> <p>Enable Printer (EN P) (VAX Console LA50) for hardcopy of remote station I/O activity.</p> <p>Remote Carrier status will be reported.</p>
<p><u>REMOTE USER</u> Keyswitch Position</p> <p>REMOTE USER indicator blinks when the remote station is not logically connected.</p> <p>RSC allows remote access to VMS through the CPU comm port with DDCMP protocol. RSC can support a comm port, but does not require it.</p>	<p>VAX Console operation is normal.</p> <p>If the CPU comm port is implemented, the remote station has access to VMS, not the VAX Console.</p>
<p><u>USER PORT</u> Keyswitch Position</p> <p>RSC is transparent. All system operation is normal.</p>	<p>If the CPU comm port is implemented, the remote station has access to VMS without protocol.</p> <p>Enable CPU Comm Port software for "Modem on"/"modem perm" if modem dial-in capability is required.</p>
<p><u>LOCKOUT</u> Keyswitch Position</p> <p>RSC disables all remote access through its modem port.</p>	<p>No RSC modem port remote access.</p> <p>System operation is normal otherwise.</p>

Table 2-4 Remote Station (Host) Commands to VAX/PC38N

COMMAND	IN P I/O MODE (\$ PROMPT)	IN C I/O MODE (>>> PROMPT)	FUNCTION
ENABLE OR DISABLE REMOTE MONITORING (EN R MON) (DIS R MON)	Yes	Yes	Enable to display remote station I/O activity on the VAX Console screen.
ENABLE OR DISABLE LOCAL COPY (COPY ON) (COPY OFF)	Yes	Yes	Enables/disables optional display/printer if one is connected to RSC at A1. (Enable for customer record of remote station I/O activity.)
ENABLE LOCAL PRINTER DISABLE LOCAL PRINTER (EN P) (DIS P)	No No	Yes No	Enables the local printer (LA50 connected to VAX Console printer port) to provide a hardcopy record of remote station I/O activity.
(!) Remote station can SEND a message to the target system operator with no return message expected.	Yes (!)	Yes (!)	An exclamation mark (!) preceding the message causes the message to be printed/displayed at the VAX Console and prevents it being seen by VMS.
(!) Remote Station and local operator can TALK to each other at their terminals.	Yes (!) Two-way.	Yes Two-way, OPA0 and the Remote Station are at the >>> prompt.	(!) required as noted above.
ENABLE OR DISABLE LOCAL VAX CONSOLE (OPA0) (EN LO C) (DIS LO C)	No	Yes	Disable prevents local operator interrupting remote operations. Enable gives parallel control.
GIVE	Existing GIVE function (parallel control) replaced by ENABLE LOCAL CONSOLE command.		

>>>SH S

.....

.....

Printer ENABLED, ONLINE. Remote Carrier:ABSENT.

Remote user:ENABLED; console:ENABLED; modem:ENABLED; monitoring:ENABLED

Program Mode settings: LOCAL=OPA0 REMOTE=OPA(4 or 5)



(These are Remote User, Remote Console, Remote Modem, and Remote Monitoring in Table 2-3. Note that Remote Carrier will be PRESENT when a remote logical connection is established.)

Figure 2-1 Typical Printout For VAX/PC38N Console "Show Status"

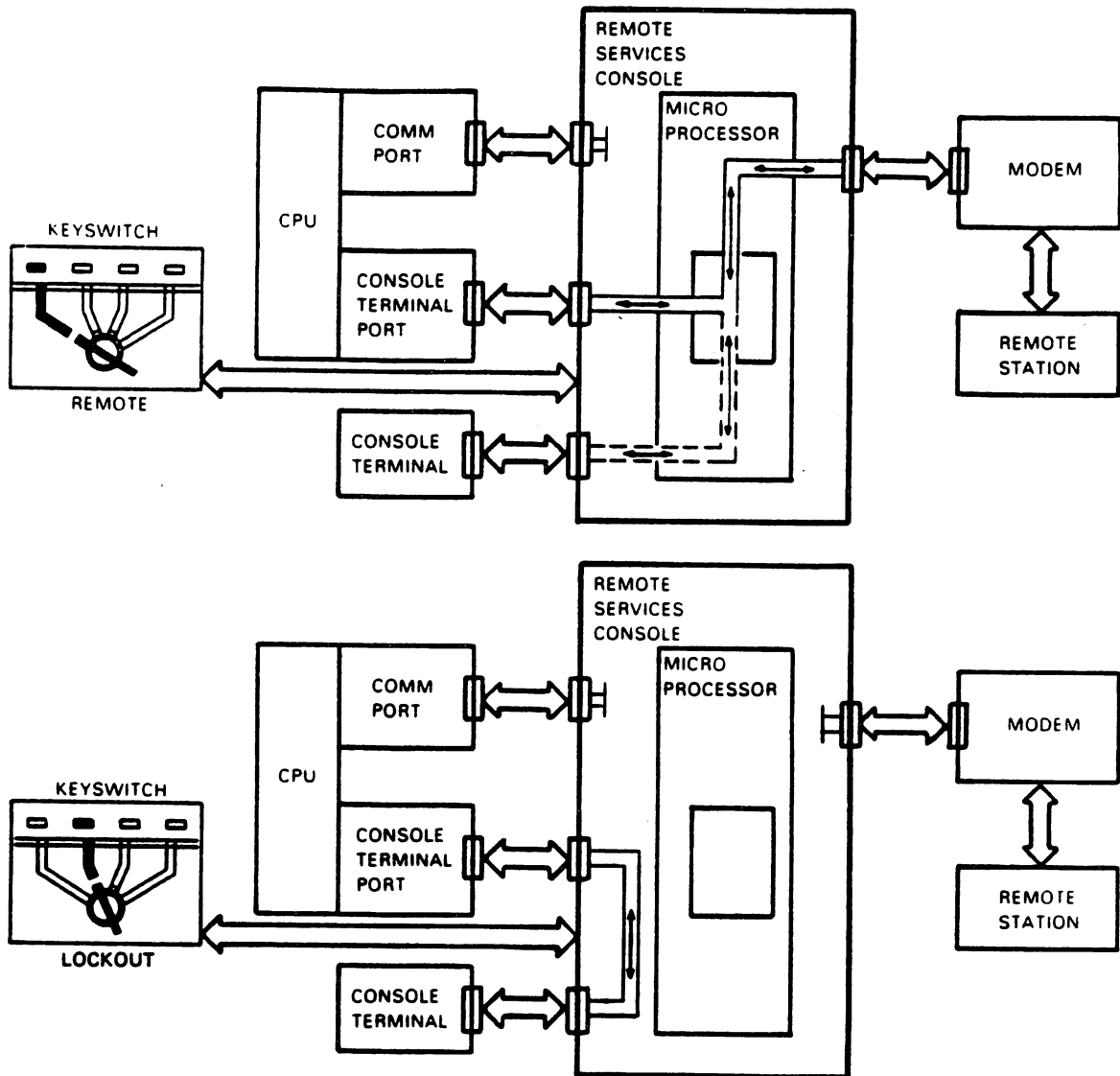

KEYSWITCH POSITION	INDICATOR	FUNCTION
<ul style="list-style-type: none"> • REMOTE 	Blinks until RSC makes a logical connection to the remote station, then it stays on.	Remote station is logically connected as console terminal. DDCMP protocol is enabled to ensure data integrity. The comm port is logically disconnected.
<ul style="list-style-type: none"> • LOCKOUT 	Shows that keyswitch is in LOCKOUT position.	No remote access through RSC modem port. Console terminal operation is normal.

Figure 2-2 Keyswitch Positions REMOTE and LOCKOUT

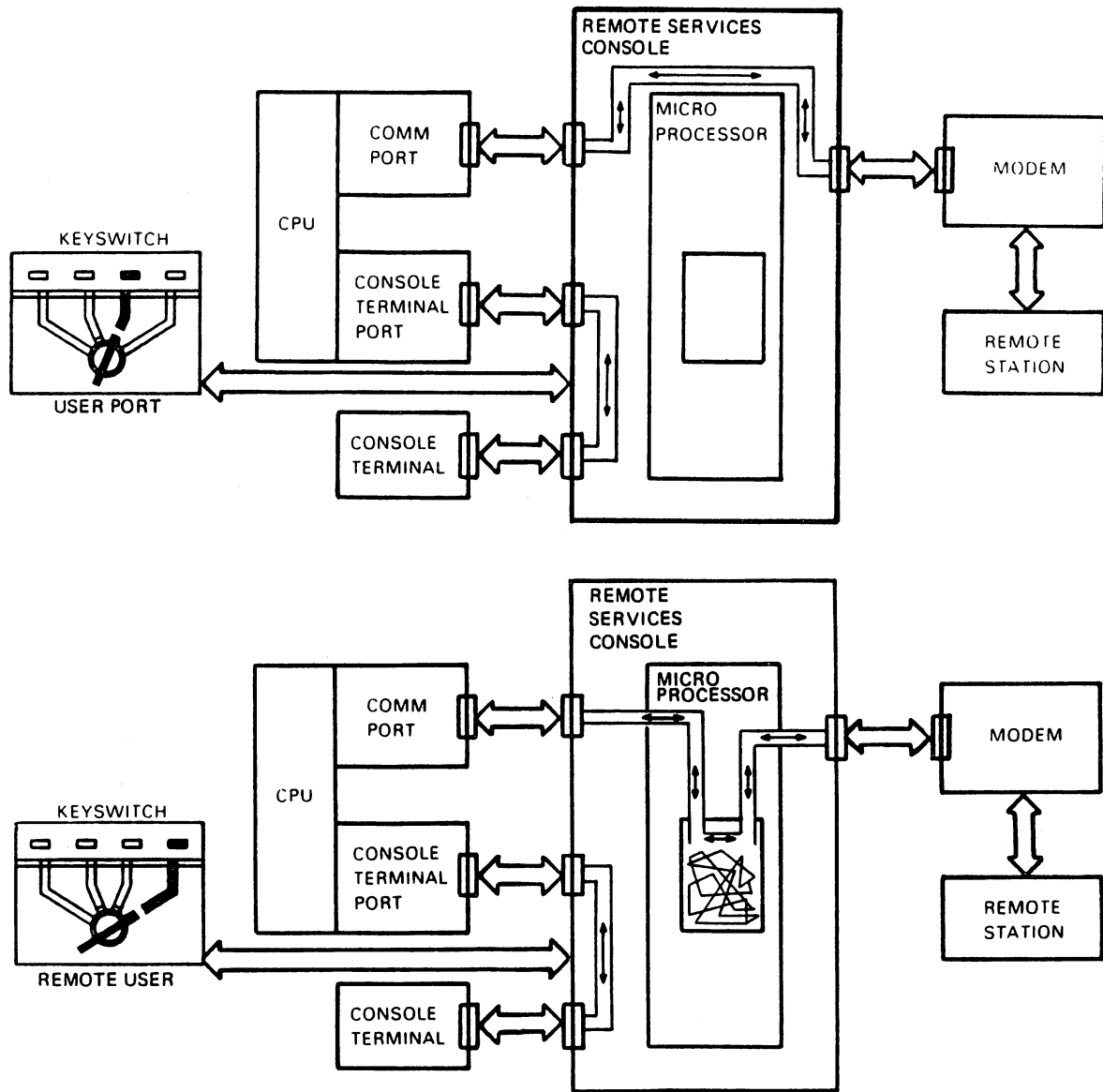

KEYSWITCH POSITION	INDICATOR	FUNCTION
<ul style="list-style-type: none"> • USER PORT 	Shows that keyswitch is in USER PORT position.	RSC is transparent. Console terminal operation is normal. Comm port and modem operation are normal (no protocol).
<ul style="list-style-type: none"> • REMOTE USER 	Blinks until RSC makes a logical connection to the remote station, then it stays on.	Remote station can access comm port with protocol. Console terminal operation is normal.

Figure 2-3 Keyswitch Positions USER PORT and REMOTE USER

Table 2-5 Other Switches and Indicators

SWITCH	INDICATOR	FUNCTION
LOCAL COPY	Shows that the keyswitch is set to REMOTE and the LOCAL COPY switch is ON.	Forces the local console terminal or other print/display terminal to print or display a record of all remote console I/O activity.
DATA RATE SWITCHES	There is no indicator.	Used to set RSC interfaces to same data rates as local console terminal and modem.
There is no power switch; RSC runs continuously.	POWER - (Green)	Shows that AC power is ON.
	FAULT - (Red)	Shows RSC failure if it stays on after the one-second self-test at power up.

2.3 POWER INDICATOR

The POWER indicator comes on when the RSC unit is plugged in; there is no power switch. The indicator tells you that the RSC unit has ac power applied.

2.4 FAULT INDICATOR

The FAULT indicator comes on when the RSC unit is plugged in. It stays on for about one second to show that the RSC power-up self-test is running. When the test is finished and there is no fault, the indicator goes off. If the test finds a fault the indicator stays on.

The RSC logic runs a self-test program continuously when the unit is not busy and turns on the FAULT indicator if it finds a fault.

2.5 DATA RATE SWITCHES

Since RSC is a data path switch, it must operate at the same data rate as the I/O devices that are connected to it. RSC has front panel switches for setting the data rate of each of its two paired interfaces (4 ports). There are three switches labeled BAUD T and three labeled BAUD M. Figure 2-4 shows you how to set the switches for data rates of 300, 1200, 2400, 4800, and 9600 b/s.

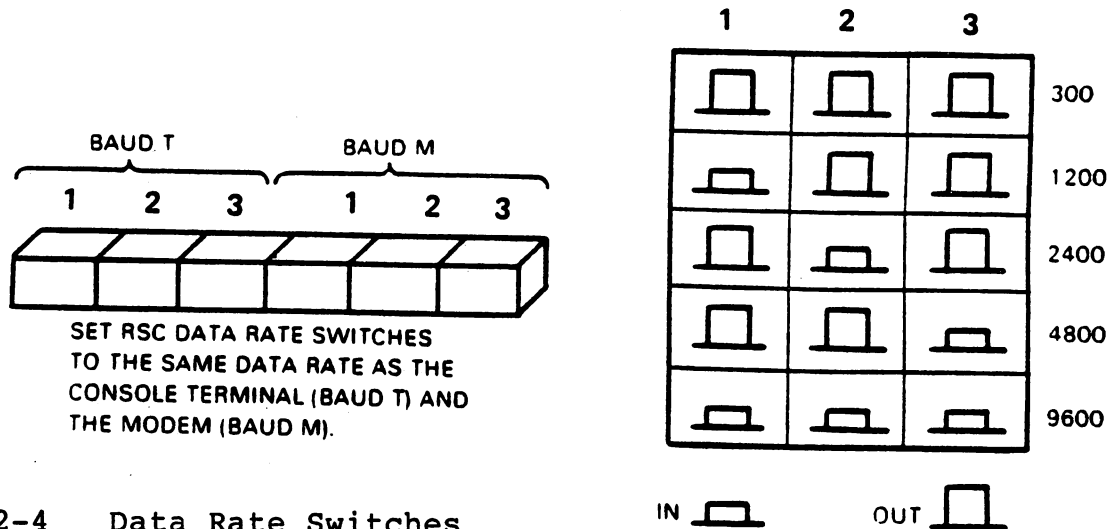

Figure 2-4 Data Rate Switches

For example, if the console terminal is operating at 9600 b/s, you must set the BAUD T data rate switches to 9600. The chart shows that the three switches must be latched in. If the modem is operating a 1200 b/s also, switch 1 latched in, switches 2 and 3 out.

VAX/PC38N NOTE

The VAX Console Remote Port is not a traditional console terminal port; it is a modem control port. Set the BAUD T switches to the same rate as the VAX Console Remote Port.

2.6 KEYSWITCH

The keyswitch controls the RSC's modes of operation. Figures 2-2 and 2-3 show the logical data paths for each keyswitch position. An operator can control remote access to the customer's system, either with or without protocol, or can prevent all remote access through the RSC modem port. By removing the key from the switch (only in the LOCKOUT and USER PORT positions), the operator can prevent anyone without a key from changing the setting, giving an added level of security.

There is an indicator for each of the four positions of the keyswitch. The indicator comes on to show the keyswitch setting. The two remote indicators blink to show RSC remote access status as explained in the following paragraphs.

2.6.1 REMOTE

The local operator sets the keyswitch to REMOTE to give a remote station (terminal or host) control of the system. DDCMP protocol is enabled to ensure data integrity. RSC logically connects the remote station to function as the system console terminal. All functions normally done by the local console terminal can be done from the remote station. The local console terminal can be enabled by either the remote operator or local operator to print a record of remote console terminal I/O activity (Paragraph 2.8). The local keyboard is normally disabled to prevent interruption of remote operation but it is enabled when the remote station invokes Talk or Parallel Control mode.

The REMOTE indicator comes on, blinking, when the keyswitch is turned to the REMOTE position. The blinking shows that the RSC logic is enabled and waiting for a remote logical connection. The console message (RSC 001) REMOTE PORT ENABLED is printed on the console terminal (Paragraph 2.7). When the connection is established, the indicator stops blinking (it stays on).

+-----+
VAX/PC38N NOTE

If, after the remote station connection is established, the operator disables the VAX Console Remote Port, all efforts made at the console keyboard to re-enable the port and establish the logical connection again will be unsuccessful. Both the telephone connection and the modem will appear to be normal.

The remote station must break, then re-make the connection after the VAX Console Remote Port has been re-enabled.

+-----+

2.6.2 LOCKOUT

The local operator can set the keyswitch to LOCKOUT (Figure 2-2) to prevent all remote access to the system through the RSC modem port. The local console terminal operates normally, but the comm port is logically disabled by RSC. The Lockout function may be a security requirement for a customer's system. If the keyswitch Lockout function is working correctly, the modem's DTR signal is

inhibited and the LOCKOUT indicator comes on. If the keyswitch is set to LOCKOUT and the indicator does NOT come on, RSC design provides two levels of security:

FIRST - it warns the operator that there is a fault and remote access may be possible.

SECOND - the RSC logic defaults to USER PORT functionality which means any possible remote access will be limited to the CPU comm port with no access to the console terminal port.

2.6.3 USER PORT

The local operator can disable remote protocol access to the system by setting the keyswitch to USER PORT (Figure 2-3). A LED indicator comes on to show this keyswitch position. With the keyswitch set to USER PORT, RSC is logically transparent and the local console terminal functions normally. When a communications port application is using the modem and telephone line, that operation is normal also (no protocol).

2.6.4 REMOTE USER

The local operator sets the keyswitch to REMOTE USER to let a remote station, using DDCMP protocol, log in to the system through the communications port. Note that local console terminal operation is normal (Figure 2-3).

The REMOTE USER indicator comes on, blinking, when the keyswitch is turned to the REMOTE USER position. The blinking shows that the RSC logic is enabled and waiting for a remote logical connection. When the connection is established, the indicator stops blinking (it stays on).

2.7 CONSOLE TERMINAL MESSAGES

RSC logic senses changes in remote access status and transmits messages that can be displayed or printed on the local console terminal. These messages tell the local operator when the remote station is making or breaking connection to the system. The messages appear only when the RSC keyswitch is set to the REMOTE position. In VAXclusters and VAX/PC38N systems, hardcopy terminals for this purpose are optional and may not be present to display or print these messages.

- o (RSC 001) REMOTE PORT ENABLED

This message is transmitted by RSC immediately after the keyswitch is turned to the REMOTE position. Unless the RSC TERMINAL DATA RATE switches are set to match the data rate of the local console terminal, the message will be garbled. (See Paragraph 2.8.)

- o (RSC 001) CONNECTION LOST

This message is transmitted when the remote station terminates the telephone connection (hangs up). This message can be transmitted also as a result of a hardware failure or loose connection, for example.

+-----+
 | VAX/PC38N NOTE |
 |
 | The VAX Console can display similar messages for the local |
 | operator when it is set up to detect a remote connection. |
 |
 +-----+

2.8 LOCAL COPY SWITCH

When the local operator sets the RSC keyswitch to REMOTE, control of the system is given to a remote station. When the remote station is the CSC, the host software usually disables the target system console terminal. The customer may want to display or print a record of what the remote station does while it has control of the system. A record of that I/O activity is displayed or printed when:

- o The CSC invokes Local Copy mode (in RSC firmware), or
- o The local operator sets the RSC LOCAL COPY switch ON, and
- o A hardcopy or display terminal has been provided for that purpose.

To summarize RSC's Local Copy functionality:

- o The local operator can force local copy by setting the RSC LOCAL COPY hardware switch.
- o The CSC can invoke (force) local copy by setting the local copy mode in RSC firmware.
- o Neither the hardware switch nor firmware setting can override the other to disable local copy.

The LOCAL COPY switch and indicator are logically functional only when the keyswitch is set to REMOTE.

VAX/PC38N NOTE

Table 2-4 shows that there are three possible configurations for terminals and/or displays to monitor remote station I/O activity.

3.1 INTRODUCTION

This chapter tells you how to do basic testing of the telephone line, the modem, and the RSC unit. The field maintenance philosophy for RSC is unit swapping. If you have any problem the CSC can help you solve it.

3.2 TROUBLESHOOTING PROCEDURES

The following paragraphs describe the procedures for RSC troubleshooting. You can do some of them, the CSC must do the others. Each procedure stands alone and should be passed successfully before going on to the next procedure. Table 3-1 is a troubleshooting aid.

3.3 CABLE TEST AND RSC BYPASS

If you cannot successfully complete a test and you suspect that either a cable or the RSC unit itself is at fault, cable patching is a "quick check". In this procedure you disconnect cables only at the RSC unit.

- o If you want to bypass RSC and test console terminal operation, disconnect (at connector A1 on the the RSC unit) the cable that goes to the console terminal. Disconnect (from RSC connector A2) the cable that goes to the CPU console terminal port. Plug the two cable connectors into each other. Console terminal operation should be normal with RSC out of the circuit.
- o If you want to bypass RSC and test the communications port, disconnect (from RSC connector B1) the cable that goes to the communications port. Disconnect (from RSC connector B2) the cable that goes to the modem. Plug the two cable connectors into each other. Communications port operation should be normal with RSC out of the circuit.
- o If the RSC unit should fail, or you want to remove it temporarily, do both of the previous steps.

3.4 POWER-UP TEST

When the RSC unit passes this test, the basic unit is working correctly. Note that the I/O interfaces are not tested until Paragraph 3.5. The tests can be made with, or without, I/O cables connected.

1. Set the RSC keyswitch to USER PORT.
2. Check to make sure that the RSC voltage select switch is set for the correct operating voltage.
3. Check to make sure that the fuse is good and is the correct value for the operating voltage.
4. Plug in the ac power cord.
5. If the POWER indicator does not come on, make sure there is ac power at the receptacle. If there is, check the power cord and the RSC fuse (again). (Installation Step 3 has information that may help you when you are replacing a fuse.) If the ac supply, the power cord, and the fuse are good, (and there is still no RSC power) replace the RSC unit.
6. If the POWER indicator comes on, the USER PORT indicator should also.
7. The FAULT indicator should come on. It should stay on for about one second while the RSC power-up self-test runs.
8. If the RSC unit is working correctly, the FAULT indicator should go out. If the self-test finds a fault, the FAULT indicator will stay on.
9. If the FAULT indicator stays on, replace the unit.

+-----+
VAX/PC38N NOTE

If you are working with a VAX/PC38N system, see Tables 2-3 and 2-4 for system set-up information which may help as you continue RSC testing.

+-----+

3.5 USER PORT TEST

If you can successfully complete this procedure, the RSC console terminal and communications port I/O interfaces are working correctly. Note that RSC can support a comm port but does not require one for its operation.

1. Set the keyswitch to USER PORT.
2. Type on the console terminal keyboard and make sure operation is normal. RSC should be completely transparent.
3. If the customer has a comm port application, ask the local operator to log in through the the communications port, telephone line, and modem. This tests not only the RSC communications port I/O interface, but also the telephone line and modem. If this test passes, you can skip Paragraph 3.6.

3.6 TELEPHONE LINE AND MODEM TEST

1. Change the keyswitch to REMOTE USER or REMOTE.
2. Check the modem to make sure the DTR indicator (if there is one) is on.
3. From a nearby telephone, dial the number of the telephone line connected to the modem.
4. You should hear a ring signal and the modem ring indicator should come on.
5. You should hear a carrier signal. Whistle into the phone at about the same frequency as the carrier signal. The modem DSR indicator should come on.
6. Hang up. The modem indicators should go off.

3.7 REMOTE USER TEST

You must have the CSC do this test. It verifies remote protocol access through the CPU communications port.

1. Set the keyswitch to REMOTE USER.
2. The REMOTE USER indicator should come on, blinking (RSC remote access is enabled and it is waiting to make a logical connection).
3. Type on the console terminal keyboard and make sure that operation is normal.

4. When the CSC makes connection, the REMOTE USER indicator should stop blinking and stay on.
5. The CSC will log into the system as a user.

3.8 REMOTE TEST

You must have the CSC do this test. It verifies remote protocol access that allows a remote station to take control of the system.

1. Set the keyswitch to REMOTE.
2. The REMOTE indicator should come on, blinking (RSC remote access is enabled and it is waiting to make a logical connection).
3. The console terminal should print the message "(RSC 001) REMOTE PORT ENABLED".
4. Check to see that the console terminal keyboard is disabled.
5. When the CSC completes the telephone connection, the REMOTE indicator stops blinking (it stays on).
6. The CSC tests RSC for correct remote operation.
7. When the CSC hangs up, the console terminal prints the message "(RSC 001) CONNECTION LOST".
8. The REMOTE indicator should start blinking.
9. After a 4 second delay, the console terminal should print the message "(RSC 001) REMOTE PORT ENABLED".

Table 3-1 Troubleshooting Chart

SYMPTOM	CAUSE OR ACTION
POWER indicator does not come on.	Check ac at receptacle and power cord. Check fuse.
FAULT indicator stays on.	The RSC unit has failed. To bypass a faulty RSC unit, disconnect console terminal cables from A1 and A2 and patch them together. Disconnect modem/comm port cables from B1 and B2 and patch them together.
LOCKOUT indicator does not come on.	If the RSC Lockout logic fails, the indicator is turned off and RSC defaults to USER PORT mode.
No remote access.	The CPU LOCAL/REMOTE switch must be set to LOCAL for RSC operation. For VAX/PC38N - If the VAX Console remote port is disabled after the remote station is connected, it cannot be re-enabled except by having the remote station break, then re-make the connection.
No USER PORT access and no DTR signal at modem.	Check modem power and connections. CPU Comm Port software may be set to "no modem".
Printout garbled or characters printed twice on terminal.	CSC has set Local Copy mode or GIVE mode and the RSC LOCAL COPY switch is also set. This problem has been resolved in MDS01 units with revisions of B1 or greater (See Page 2-13)
Printout garbled.	Terminal must be set for 8-bit, no parity.
CPU will not boot.	If the RSC keyswitch is set to REMOTE, the local console terminal is disabled.

APPENDIX A

USER GUIDE

INTRODUCTION

This appendix is a copy of the RSC User Guide, EK-KCRSC-UG, that is shipped with the RSC unit. The guide is printed on heavy paper stock and is intended for use by the customer.

A second RSC User Guide, EK-KCRSC-SM, is also shipped with the RSC unit. That guide has the same information, but it is printed on plain paper and is to be inserted into the Site Management Guide binder behind the "R/D" tab.

Remote Services Console

User Guide



LOGICAL DATA PATHS FOR EACH KEYSWITCH POSITION

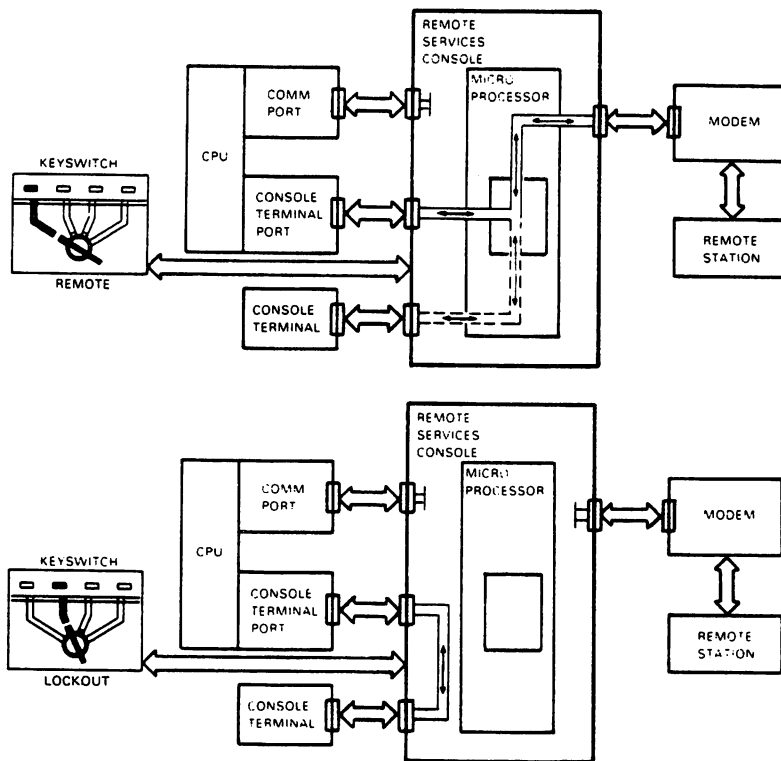

KEYSWITCH POSITION	INDICATOR	FUNCTION
<ul style="list-style-type: none"> ● REMOTE 	Blinks until RSC makes a logical connection to the remote station, then it stays on.	Remote station is logically connected as console terminal. DDCMP protocol is enabled to ensure data integrity. The comm port is logically disconnected.
<ul style="list-style-type: none"> ● REMOTE USER 	Blinks until RSC makes a logical connection to the remote station, then it stays on.	Remote station can access comm port with protocol. Console terminal operation is normal.
<ul style="list-style-type: none"> ● USER PORT 	Shows that keyswitch is in USER PORT position.	RSC is transparent. Console terminal operation is normal. Comm port and modem operation are normal (no protocol).
<ul style="list-style-type: none"> ● LOCKOUT 	Shows that keyswitch is in LOCKOUT position.	No remote access through RSC modem port. Console terminal operation is normal.

LOGICAL DATA PATHS FOR EACH KEYSWITCH POSITION

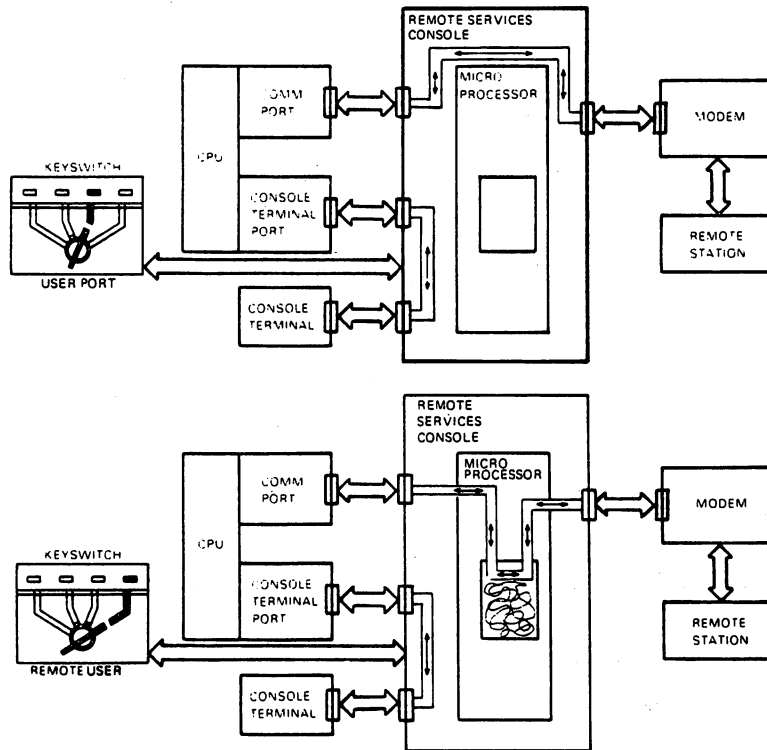

THE OTHER SWITCHES AND INDICATORS

SWITCH	INDICATOR	FUNCTION
LOCAL COPY SWITCH	Shows that keyswitch is set to REMOTE and local copy switch is ON.	Forces local console terminal to print a record of remote console terminal I/O activity.
DATA RATE SWITCHES (BAUD T AND BAUD M)	No indicator	These switches set RSC interfaces to same data rates as local console terminal and modem.
No power switch	POWER - Green	Shows that ac power is on.
-	FAULT - Red	Shows RSC fault if on after one second self-test at power-up.

REMOTE SERVICES CONSOLE USER GUIDE

OPERATION

1. Make sure RSC Data Rate Switches are set correctly.
2. Set RSC keyswitch to select mode of operation.
3. Check the RSC indicators -
 - POWER - on
 - FAULT - off
 - KEYSWITCH position indicator - on
 - LOCAL COPY - on if the RSC keyswitch is set to remote and the LOCAL COPY switch is latched in.
4. For VAX/PC38N or VAX Cluster - You may have to connect and/or enable a hardcopy terminal if you want to use LOCAL COPY.
5. For VAX Cluster - You will have to change the Z Box (VCS Disable) switch setting to disconnect the target CPU from the cluster and enable a hardcopy terminal.

TO SET DATA RATE SWITCHES

RSC must operate at the same data rate as the console terminal and modem that are connected to it. The BAUD T and BAUD M switch settings determine the data rates of those RSC interfaces.

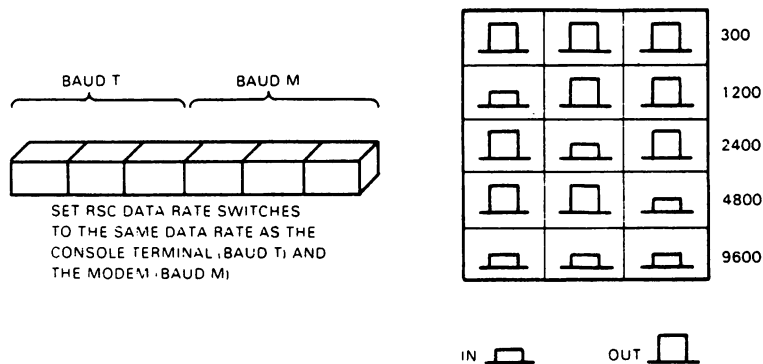

RSC OPERATION NOTES

- The key can be removed from the RSC keyswitch when it is set to LOCKOUT or USER PORT.
- The CPU LOCAL/REMOTE switch must be set to LOCAL or LOCAL DISABLE (not a remote position) for RSC operation.
- System setup must specify "modem" or "modem/perm" to enable RSC remote operation.
- The CPU will not boot if the RSC keyswitch is set to REMOTE. The console terminal is disabled.
- The LOCAL COPY indicator comes on only when the RSC keyswitch is set to REMOTE because the local copy logic is not functional in the other keyswitch positions.
- If the lockout logic fails, the LOCKOUT indicator will not come on and RSC will default to USER PORT mode.
- To bypass a faulty RSC unit, unplug console terminal cables from A1 and A2 and patch them together. The B1/B2 cables can be patched to connect the comm port to the modem.
- For VAX/PC38N - If, after the remote station connection is established, the operator disables the console remote port, all efforts made at the console keyboard to re-enable the port and re-establish the logical connection again will be unsuccessful. Both the telephone connection and modem operation will appear to be normal. The remote station must break, then re-make the connection after the console remote port has been re-enabled.

INDEX

A

AC power, 1-2
 Accessibility of RSC, 1-3
 Adapter,
 for VAX/PC38N, 1-1, 1-3, 1-14

B

Baud M/T, see Data Rate switches
 BC22D, 1-11
 BC22E/BC22F cable, 1-3
 installation, 1-14
 Booting, 2-2, 3-5
 Bypassing a failed RSC, vii, 3-1

C

Cable,
 BC22D, 1-7, 1-11
 BC22E/BC22F, 1-3
 configuration table, 1-14
 installation, 1-7, 1-11
 RSC configuration, 1-12
 test, 3-1
 type required, 1-3
 Certifications, vii
 Comm port, 1-2
 test, 3-3
 "Connection Lost message",
 1-16, 2-13
 Console terminal, 1-7, 2-2
 messages, 1-16, 2-12
 Console terminal port, 1-14, 1-15
 CPU LOCAL/REMOTE switch, 2-2

D

Data Rate switches,
 vii, 1-15, 2-2, 2-4, 2-9
 DDC/RDC
 installation test, 1-18
 user account, 1-7
 DDCMP protocol, vi, 2-2, 2-4
 DF03/DF112 modem, 1-2
 Documentation, viii
 RSC User Guide, A-1
 Site Management Guide, A-1
 DSR/DTR, 1-16

E

EIA connectors, 1-14, 3-1

F

Fault indicator, 2-9, 3-2
 FCC modem data, 1-2
 Features, vi
 Field Transaction Report, 1-18
 Fuse, 1-4

G

Generic installation overview, 1-8

I

Installation,
 DDC testing, 1-18
 FCC modem data, 1-2
 kit contents, 1-3
 modem, 1-1, 1-14
 procedure, 1-3
 removing, 1-20
 site preparation, 1-1

K

Key, vii, 2-10
 Keyswitch,
 operation, 2-2, 2-4, 2-7, 2-10
 testing, 1-16, 1-17
 Kit contents, 1-3

L

Label, RSC front, 1-5
 Local copy, 2-9, 2-13
 Lockout keyswitch position,
 operation, 2-2, 2-4, 2-7, 2-11
 testing, 1-17
 Logical connection, 2-7, 2-11

INDEX

M

Messages, console terminal,
 1-16, 2-12
 Modem on/perm, no modem
 1-17, 2-2, 2-4
 data rates, 1-15
 DF03/DF112, 1-2
 test, 1-15, 3-3
 type required, 1-1

N

/no modem, 1-17, 2-2, 2-4

O

Operator Information
 generic systems, 2-2
 VAX/PC38N, 2-4

P

PC38N - See VAX/PC38N
 Power indicator, 2-9
 Protocol, DDCMP, vi, 2-2, 2-4

R

Remote keyswitch position,
 operation, 2-2, 2-4, 2-7, 2-11
 testing, 1-15, 3-4
 Remote diagnosis, vii
 "Remote port enabled" message,
 1-16, 2-13
 Remote services delivery, vi
 Remote User keyswitch position,
 operation, 2-2, 2-4, 2-8, 2-12
 testing, 1-16, 3-3
 Removing RSC, 1-20

S

Self-test, 1-6, 2-1, 2-9
 Site Management Guide, A-1
 Site preparation, 1-1
 Switch,
 data rate, vii, 1-15, 2-9
 keyswitch, 2-10
 local copy, 2-13
 voltage select, 1-4

T

Talk, 2-5
 Telephone line, 1-1
 test, 3-3
 Terminal set-up, 1-15, 2-2
 Transaction Report Form, 1-18
 Troubleshooting, 3-5

U

User account, 1-7
 User Guide, 1-18, A-1
 User port keyswitch position
 operation, 2-2, 2-4, 2-8, 2-12
 testing, 1-17, 3-3

V

VAXcluster information will be
 added in the next revision.
 VAX/PC38N,
 adapter, 1-1, 1-3, 1-14
 BAUD T switches, 1-15, 2-10
 console, 2-4
 commands, 2-4
 remote port, 1-15, 2-4
 installation overview, 1-9
 operator information, 2-4, 2-5
 Remote Port, 2-11
 Voltage Select switch, 1-4