

PHILIPS

P855M

MIOS Drivers

Users Guide



**Data
Systems**

M.I.O.S. DRIVERS P855/860

An option to SRTM / BRTM

Users Guide

List of Effective Pages

This software manual, publication number 5122 991 12342, was originally published in September 1973; Revision 1 was issued in February 1974.

1 through 3	Rev. 1	15 through 18	Original
4 through 5	Original	19 through 28	Rev. 1
6	Rev. 1	29	Original
7 through 10	Original	30 through 30.1	Rev. 1
11 through 12	Rev. 1	31 through 35	Original
13	Original	36 through 55	Rev. 1
14	Rev. 1		

A publication of
Philips-Electrologica B.V.
Main Marketing Group - OEM
Apeldoorn, Netherlands

Publication number 5122 991 12342

January 1974

Copyright © by Philips-Electrologica B.V., 1973
All rights strictly reserved. Reproduction or issue to
third parties in any form whatever is not permitted
without written authority from the publisher.

This handbook describes the MIOS input/output drivers, which are part of the Small Real Time Monitor and can be fitted into the Basic Real Time Monitor without any modification.

The related manuals are:

P855M/P860M Basic Real Time Monitor	5122 991 11581
P855M/P860M Small Real Time Monitor	5122 991 12321
P855M/P860M Timer Function SRPM	5122 991 12331

Great care has been taken to ensure that the information contained in this handbook is accurate and complete. Nevertheless, should a user find any errors or omissions or wish to suggest improvements, he is invited to write his comments on the sheet provided at the end of the book and send it to:

Mr. D.G.M. Bos or Mr. A.C.P. Debie
NV Philips
MID - PIT/IDS
Building TQV-3
Eindhoven
Tel. 040 - 782563/784009

CONTENTS.

	<u>Page:</u>
1. Introduction.	1
2. Functional Characteristics.	4
3. MIOS' Monitor Request.	5
4. Programming Conventions.	11
5. Configuration.	12
6. Loading Sequence.	14
7. Block Diagrams.	15
8. Testprogram.	35

1. Introduction.

1.1. The drivers specified below perform the following functions:

MIOS 4D or 4A

- digital input
- digital output
- analog input
- analog output

MIOS 4C stand alone

- analog input
- analog output

1.2. Applicable documents

PIT service publications:

- PC 1203/00 for MIOS 4D
- PC 1204/00 for MIOS 4C

The MIOS 4A can use one out of three analog-to-digital converters (see diagram 1):

- DVM (Digital Volt Meter)
- Stand alone ADC
- MIOS 4C

1.3. The drivers are part of the SRTM (Small Real Time Monitor) and can be fit into the BRTM (Basic Real Time Monitor) without modification.

1.4. The MIOS handling is not inserted into the existing input-output handling requested by "LKM - DATA 1", but treated by a new monitor request "LKM - DATA 19".

Reasons:

- The handling of the MIOS on programmed channel, being a double addressing system, differs essentially from the handling of a character device on programmed channel.

- Implementation of the MIOS handling into the BRTM can be done without modification of the character device handling.
- Some MIOS modules require an extremely fast handling, which can only be reached by a dedicated monitor request.

1.5. The number of possible MIOS modules is much larger than the nine modules handled in this guide. Therefore one should regard this MIOS software system as the way how the different modules shall be programmed.

2. FUNCTIONAL CHARACTERISTICS

The MIOS software system includes nine drivers.

- MIOS 4D/4A
- digital input (programmed channel, non-interrupt basis)
- digital/analog output (programmed channel, non-interrupt basis)
- analog input (programmed channel, interrupt basis) (ADC)
- analog input (programmed channel, interrupt basis) (DVM)
- analog input (programmed channel, interrupt basis) start conversion by MIOS 4D (MIOS 4C)
- MIOS 4C stand alone (only designed, not coded)
- analog input (programmed channel, interrupt basis) (external start ADC)
- analog input (programmed channel, interrupt basis) (internal start ADC)
- analog input (multiplex channel) (internal/external start ADC)
- analog output (programmed channel, non-interrupt basis)

word 3 : Effectieve length which has been transmitted (in words)
word 4 : Status bits; bit 15 set means control error during trans-
word 5 : Can contain two formats, specified by bit 0 mission.
of word 2.

- Format 1 F = 1

Word 5 contains the control data parameter itself.
For parameter specification see 3.6.

Use of format 1:

- the required length is one
- the required length exceeds one;
the parameters are identical for all consecutive modules
or channels.

The module/channel number is increased by the driver.

- Format 2 F = 0

Word 5 contains the address of the control data parameter
block. This block holds as many parameters as indicated by
the required length. The parameters are the same as used with
format 1, so see 3.6.

Use of Format 2:

- the module/channel numbers are not consecutive;
- the required length exceeds one: the parameters are
not the same for all modules/channels.

Note: In case of MIOS 4C stand alone, word 5 is not used.

3.3. MIOS - codes

The MIOS-codes consist of 2 hexadecimal characters. Each MIOS-
code refers to a device via the MIOS-code table. In here the
linkage is made between MIOS-code and Device Work Table.

Standard MIOS-code assignments:

- 1 digital input (DISM)
- 2 digital/analog output (DOSM)
- 3 analog input DVM
- 4 analog input ADC
- 5 analog input M4C
- 6 analog input M4C - ext.
- 7 analog input M4C - int.
- 8 analog input M4C - DMC
- 9 **analog outputs M4C**

3.4. Device Work Tables MIOS - drivers

To each driver a Device Work Table is associated, formatted as follows:

(activation) driver address	word 0
ECB address	word 1
buffer address	word 2
required length	word 3
effective length	word 4
parameter (block address)	word 5
controller status address	word 6

In the MIOS monitor request, the kind of driver is specified by the MIOS-code in ECB Word 0.

3.5. Controller status block

To each controller a status block is assigned, which has the following format:

F		word 0
DWT - address		word 1

word 0 : bit 0 = 1 : controller free
 = 0 : controller busy
 word 1 : addr. of the DWT operating now

The CSB's of the MIOS drivers are part of the CSB pool declared in the SRTM. If BRTM is used, the module C:SBM is to be loaded, in which the CSB's are declared particularly.

3.6. Parameter and input/output data specification.

The information given below is necessary to know in which format data can be send to a MIOS-module and in which format data is received from a MIOS-module.

3.6.1. DI - Digital Input.



A = address of the D.I. - channel

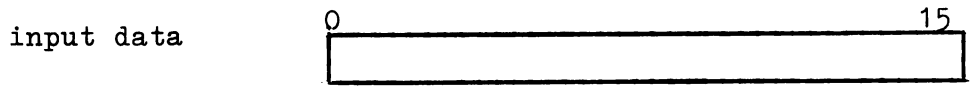

- a) 16 individual values : bit by bit.
- b) 4 hexa-decimals

3.6.2. DO - Digital Output.



A = address of the DO - channel

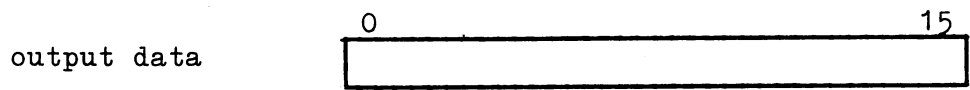

- a) 16 individual values : bit by bit
- b) 4 hexa-decimals

3.6.3. AV - Analog input DVM

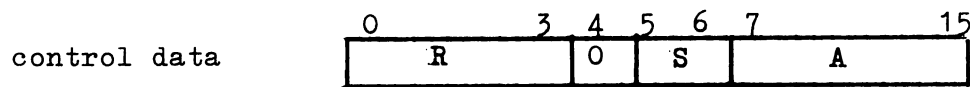

R = range, coded as follows:

0110	20 mV
0101	200 mV
0100	2 V
0011	20 V
0010	200 V
0001	1000 V
1000	AUTO

S = sampling time, coding :

00	2 msec.
01	2 msec.
10	20 msec.
11	100 msec.

A = address of the AI-channel

max. channel no : /1FF

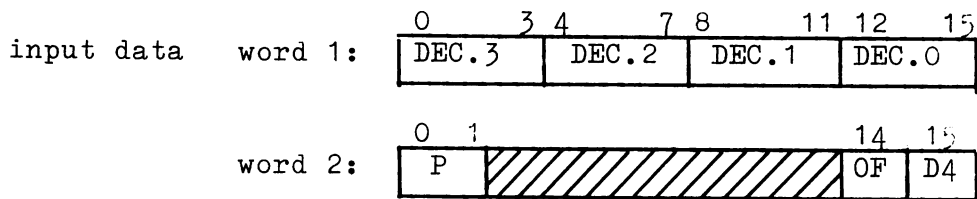

P = polarity, coding

10 positive

01 negative

OF = overflow when bit set

D4 = most significant decade.

3.6.4. AA - Analog input ADC.

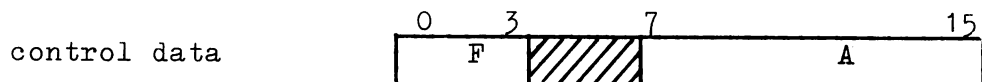

F = function bits, specifying the gain as follows:

0000	AIDC	switched off
0001	check	offset ADC
0010	check	offset amp. 2x
0011	check	offset amp. 5x
0100		

0101	SOMA 3	1x
0110	SOMA 3	2x
0111	SOMA 3	5x
1000		
1001	SOMA 2	1x
1010	SOMA 2	2x
1011	SOMA 2	5x
1100		
1101	SOMA 1	1x
1110	SOMA 1	2x
1111	SOMA 1	5x

A = address of the AI - channel

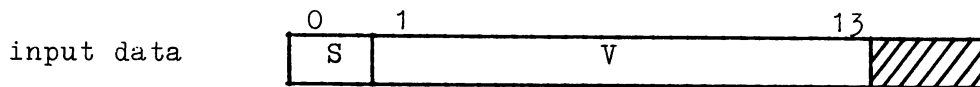

S = sign bit

V = binary value

If the sign bit is set, the negative value is given in two's complement.

3.6.5. AC - Analog input M4C

Identical to Analog input ADC, see 3.6.4.

4. PROGRAMMING CONVENTIONS.

- 4.1. The MIOS monitor request can only be used in software priority level programs(levels 50 - 63).
- 4.2. The DWT's are part of the monitor. The ECB's have to be composed by the user.
- 4.3. For analog inputs, the user itself can give a Wait monitor request for synchronisation purposes.
- 4.4. MIOS - drivers cannot be attached to a software level program.
- 4.5. Interrupt from digital input modules shall be processed by a user IM-program, labeled by I:DI.

5. CONFIGURATION

5.1. MIOS device address.

In case the device-address of the MIOS 4D is not /3E, one should change the equivalence specification at the top of each driver used.

5.2. MIOS-code Table.

Identifier : M:CT.

This table has already been build for the standard MIOS-codes.

If it has to be extended, mind the following points:

- start-address shall be the first address of the table minus 2. It shall be labeled by M:CT, the end-address (last location + 1) by M:CTEN. Both labels shall be declared in the entry-list.

- The linkages in this table, pointing to the Device Work Tables of the corresponding drivers shall be declared in the external-list.

5.3. Device Work Tables MIOS drivers.

Identifier : D:WTM

The DWT's for the standard MIOS drivers have already been made.

The lay-out has been given in 3.4. If the block of MIOS DWT's has to be extended mind the following points:

- contents of the DWT:

word 0 : start-address of the driver;
 shall be declared in the external list.

word 1 to word 5 : not to be filled in.

word 6 : controller status-address; shall be declared in the external-list.

If a new DWT is added, also a new CSB shall be made (see 5.4.).

- start-address of the DWT-pool shall be labeled by D:WTM, end-address by D:WTME.

Both labels shall be declared in the entry-list.

- start-address of each DWT shall be labeled by the name used in the MIOS-code table. These labels shall be declared in the entry-list.

5.4. Controller Status Blocks.

For each driver (controller) two locations shall be reserved to enable a check on controller free status.

For the standard drivers the CSB's have already been made.

If a driver is added, a new CSB shall be added to the block of CSB's.

For SRTM the MIOS-CSB's are part of the CSB-pool for all drivers.

For BRTM a separate CSB-pool has been made for MIOS-drivers.

By updating mind that :

- the first address of the CSB shall be labeled by the name used in the DWT (word 6). This label shall be declared in the entry list.

- both reserved locations need not to be filled with any value.

6. LOADING SEQUENCE.

If one of the MIOS-drivers is used, the following modules shall be loaded in this order:

- M:CT
- D:WTM
- C:SBM (only BRM)
- M:MIOS
- Drivers
- M:INM
- M:OTM
- R:TRNM
- I:MIOS

Loading of these modules can be done as a continuation of monitor-loading, before loading the user-tasks.

Survey of Mios modules.

Disk-no.	Name	Length
M100.S	M:CT	5
M101.S	D:WTM	35
M102.S	M:MIOS	44
M103.S	D:RDI	17
M104.S	D:RDO	30
M105.S	D:RAV	37
M106.S	D:RAA	27
M107.S	D:RAC	22
M108.S	M:INM	20
M109.S	M:OTM	19
M110.S	R:TRNM	17
M111.S	C:SBM	6
M112.S	I:MIOS	10

7. Block Diagrams.

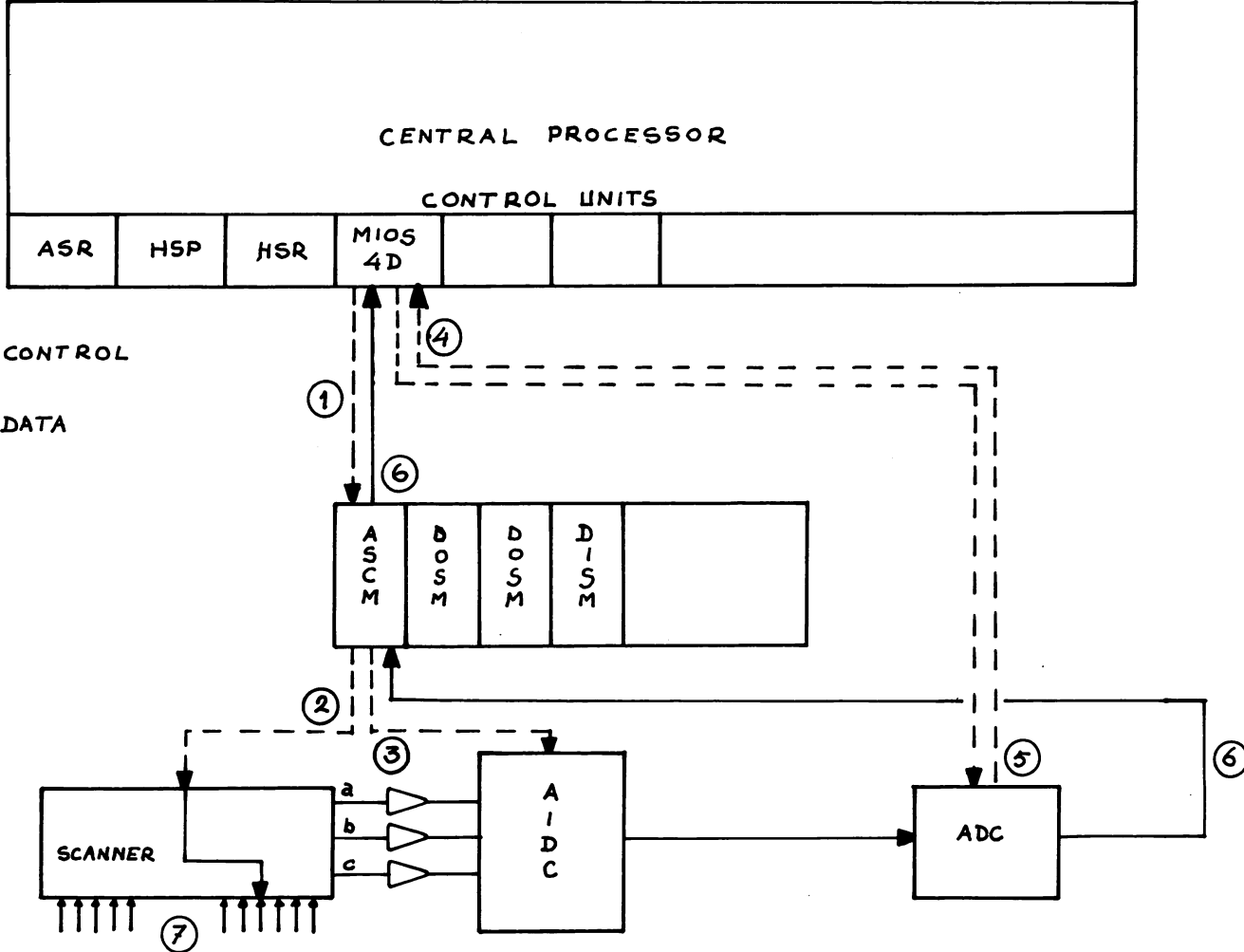

----- CONTROL
 _____ DATA

Diagram 1
 MIOS 4D/A WITH ADC CONVERTOR

- ① SELECT ANALOG SCAN CONTROL MODULE
- ② SELECT ANALOG INPUT CHANNEL
- ③ SELECT RANGE
- ④ START ADC (CONVERSION)

- ⑤ READY SIGNAL ADC
- ⑥ CONVERTED ANALOG VALUE
- ⑦ ANALOG INPUTS

MAIN AMPLIFIERS :
 a. LOW LEVEL REED
 b. HIGH LEVEL REED
 c. SOLID STATE

MIOS 4D/A WITH M4C CONVERTOR

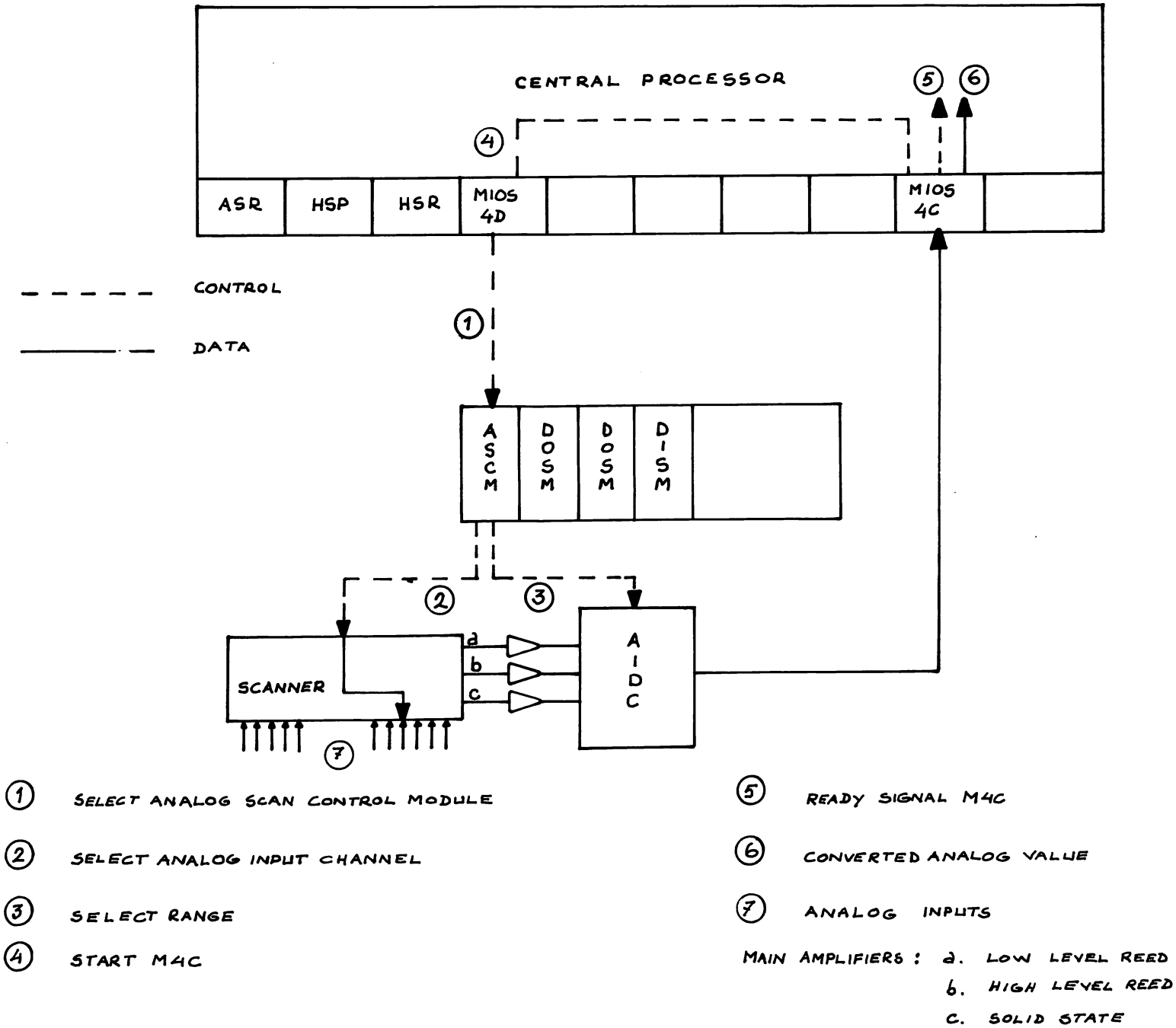

2. MIOS MONITOR REQUEST

ENTRY : A8 : ECB-
ADDRESS

EXIT : A6 : DWT-
ADDRESS

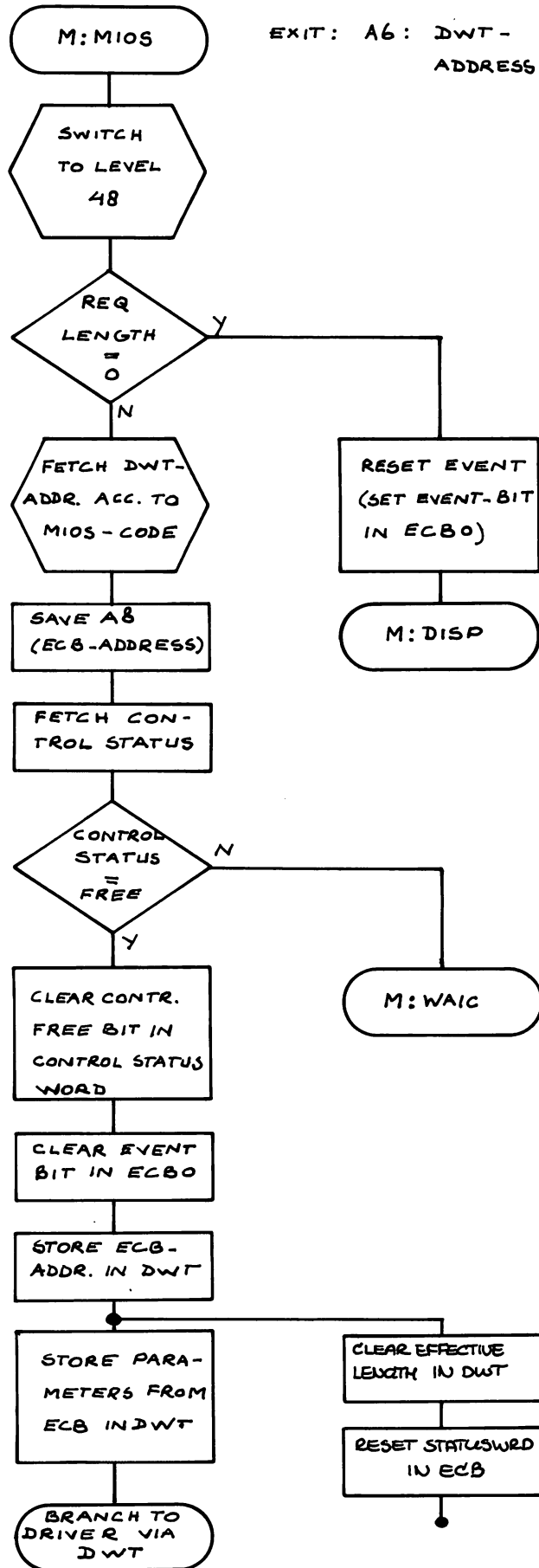

3. DIGITAL INPUT DRIVER

ENTRY: A6: DWT
ADDRESS

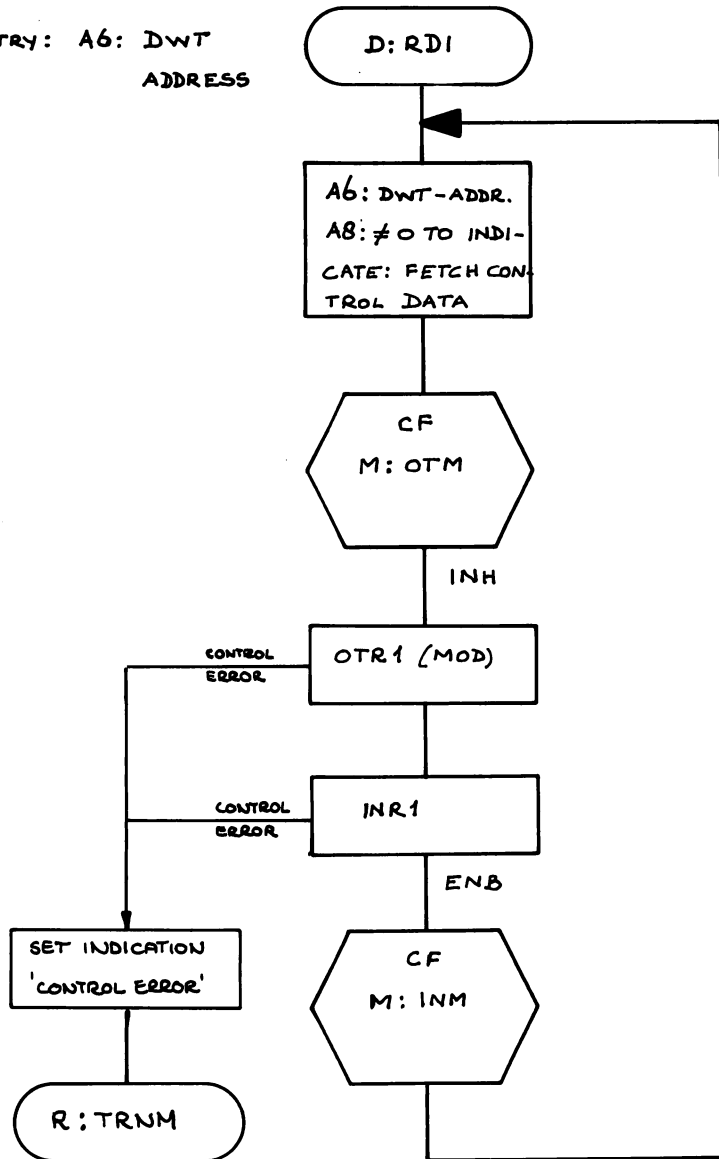

4. DIGITAL OUTPUT
ANALOG OUTPUT } DRIVER

ENTRY: A6: DWT -
 ADDRESS

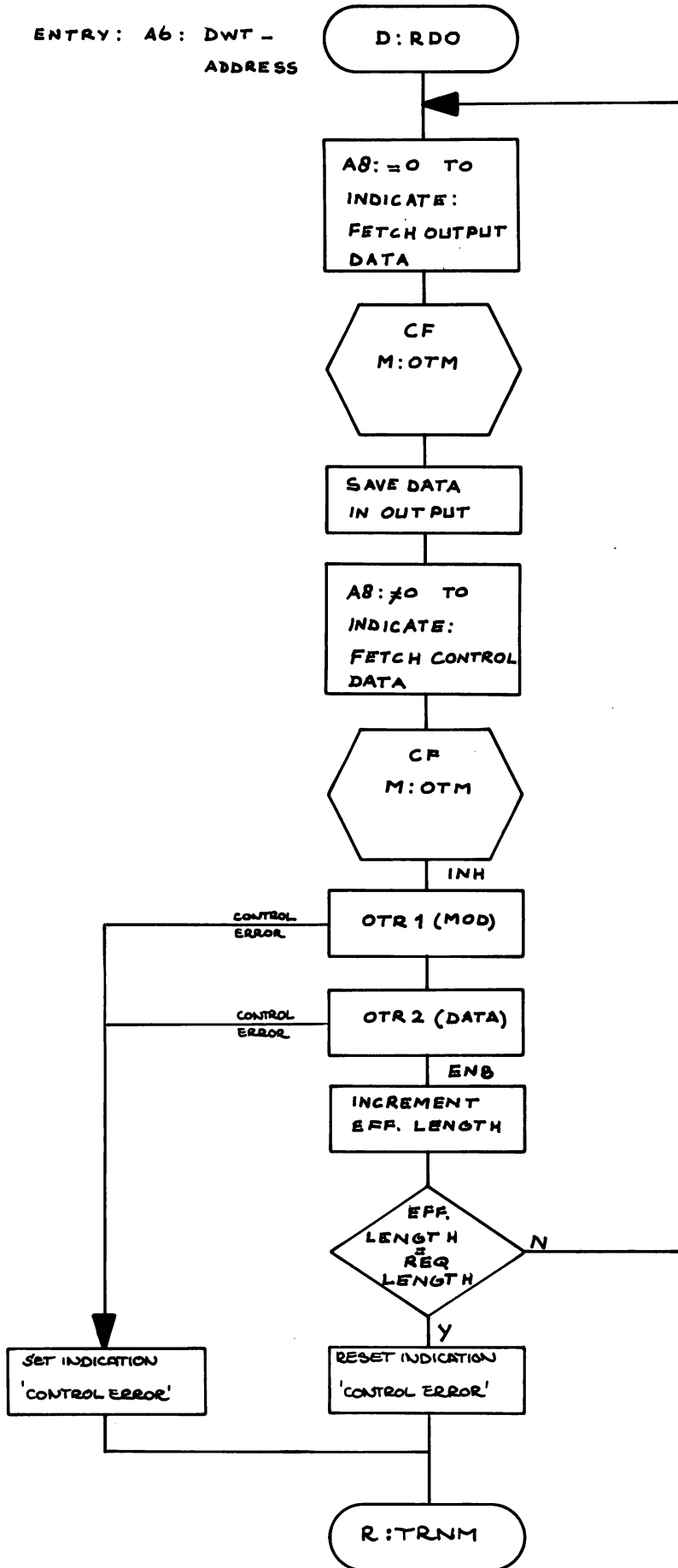

5. ANALOG INPUT DRIVER

DVM

Activation

ENTRY: A6: DWT -
ADDRESS

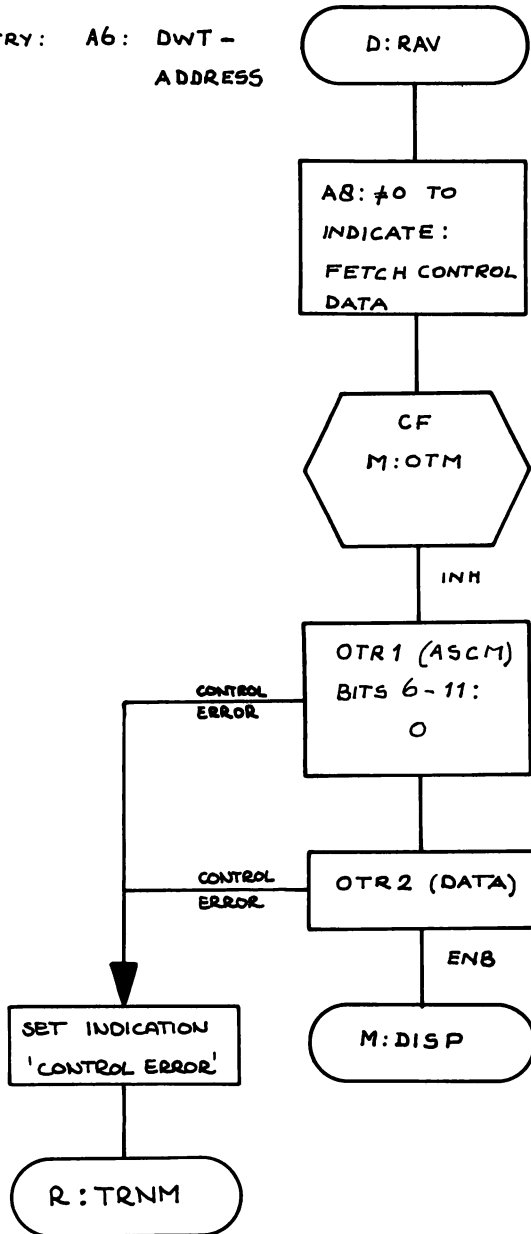

SELECTION OF ASCM
OUTPUT MODE (SCANNER)

SELECTION OF CHANNEL,
RANGE AND MEASURING
SPEED

5. ANALOG INPUT DRIVER

DVM

Interrupt Mode Part

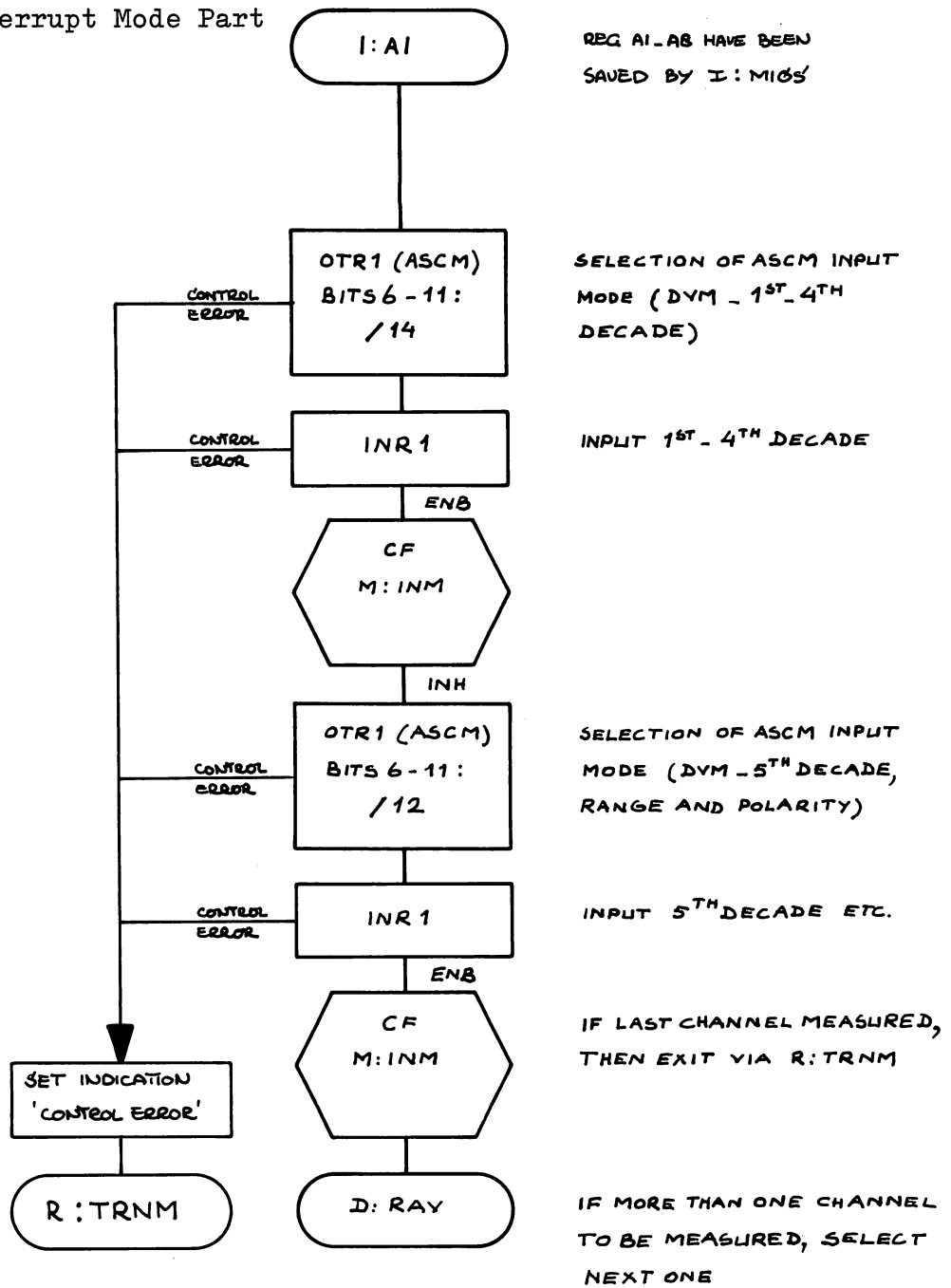

6. ANALOG INPUT DRIVER

ADC

Activation

ENTRY: A6: DWT-
ADDRESS

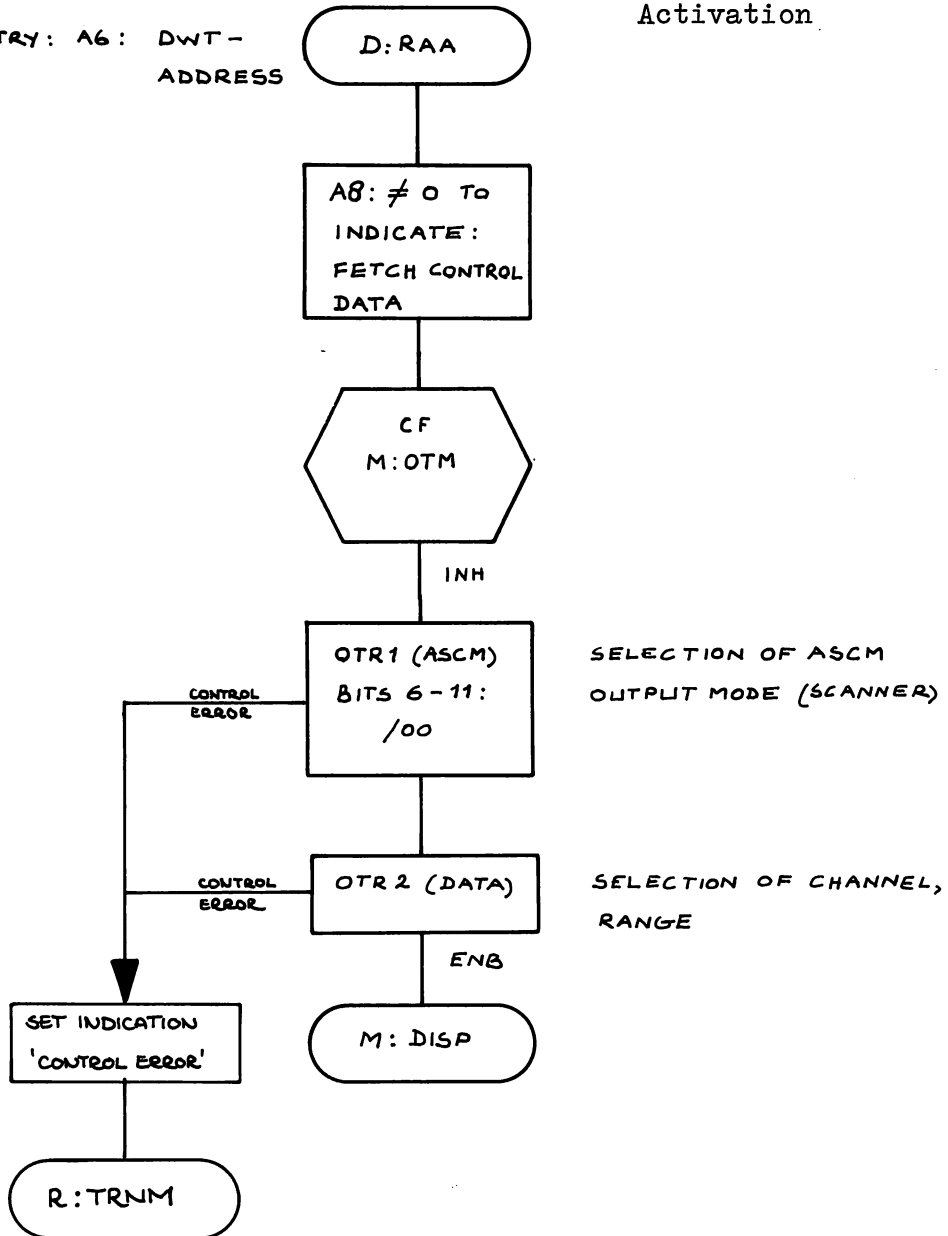

6. ANALOG INPUT DRIVER

ADC

Interrupt Mode Part

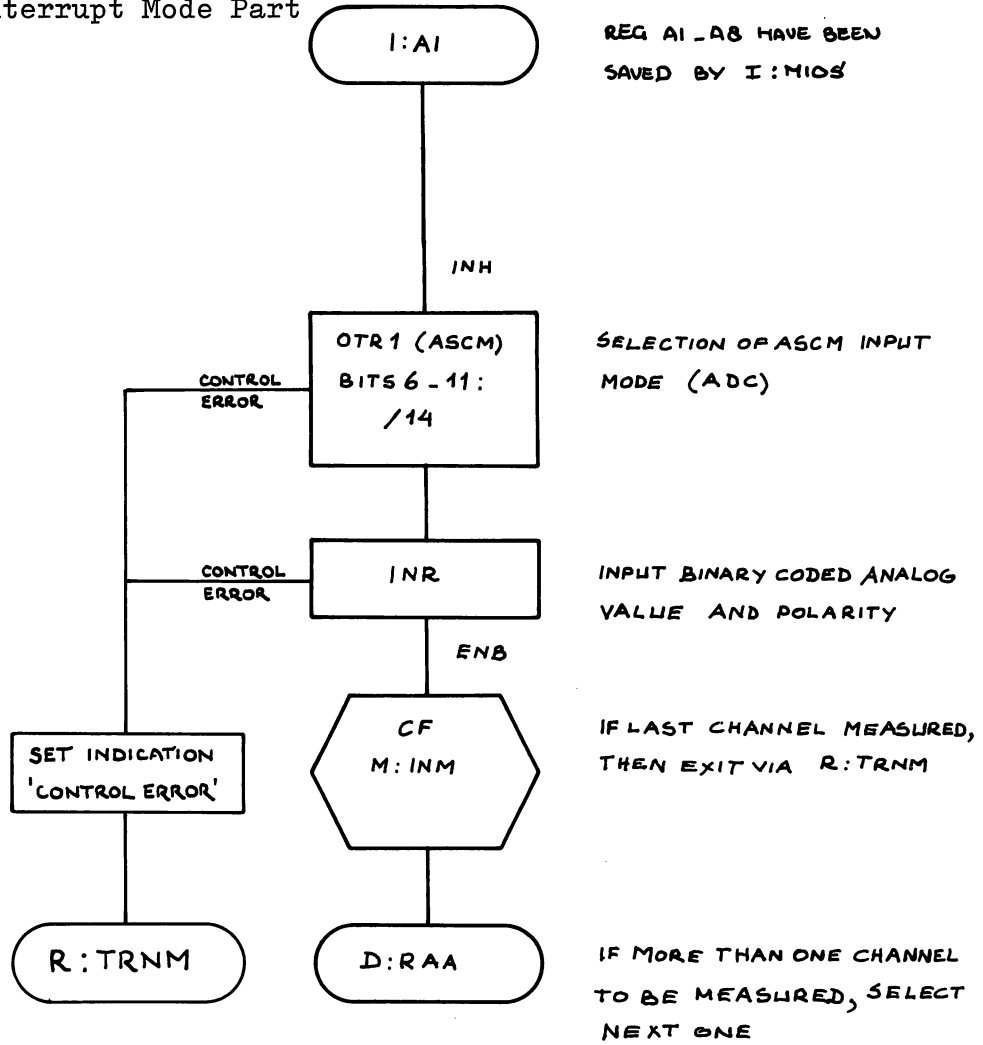

7. ANALOG INPUT DRIVER

M4C

Activation

ENTRY : A6: DWT-
ADDRESS

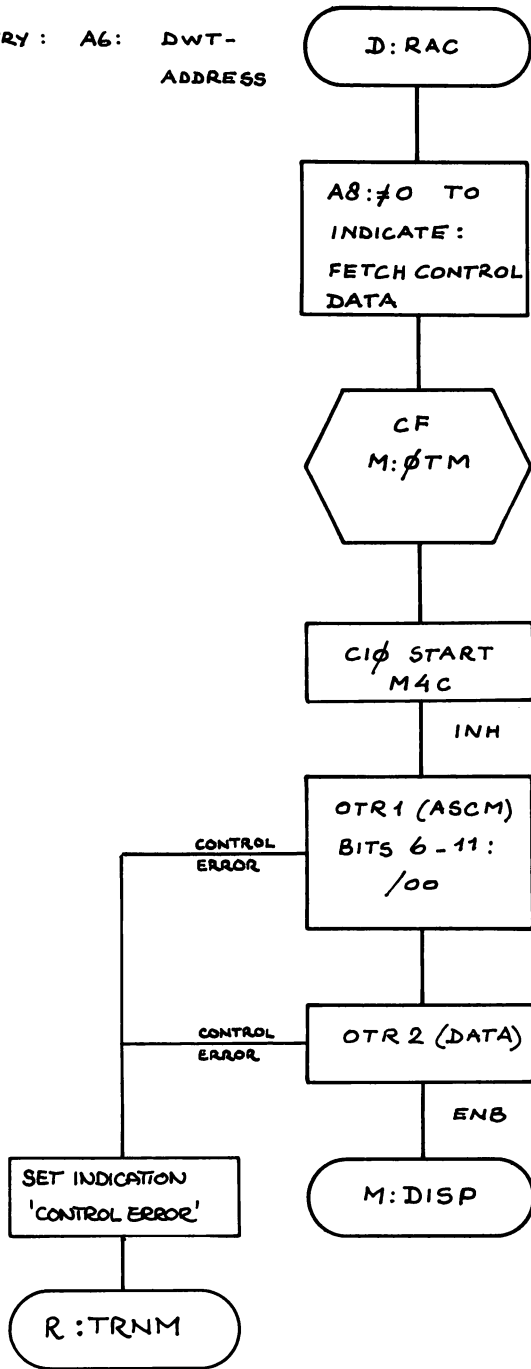

SELECT A6CM OUTPUT MODE (SCANNER)

SELECTION OF CHANNEL AND RANGE

7. ANALOG INPUT DRIVER

M4C

Interrupt Mode Part

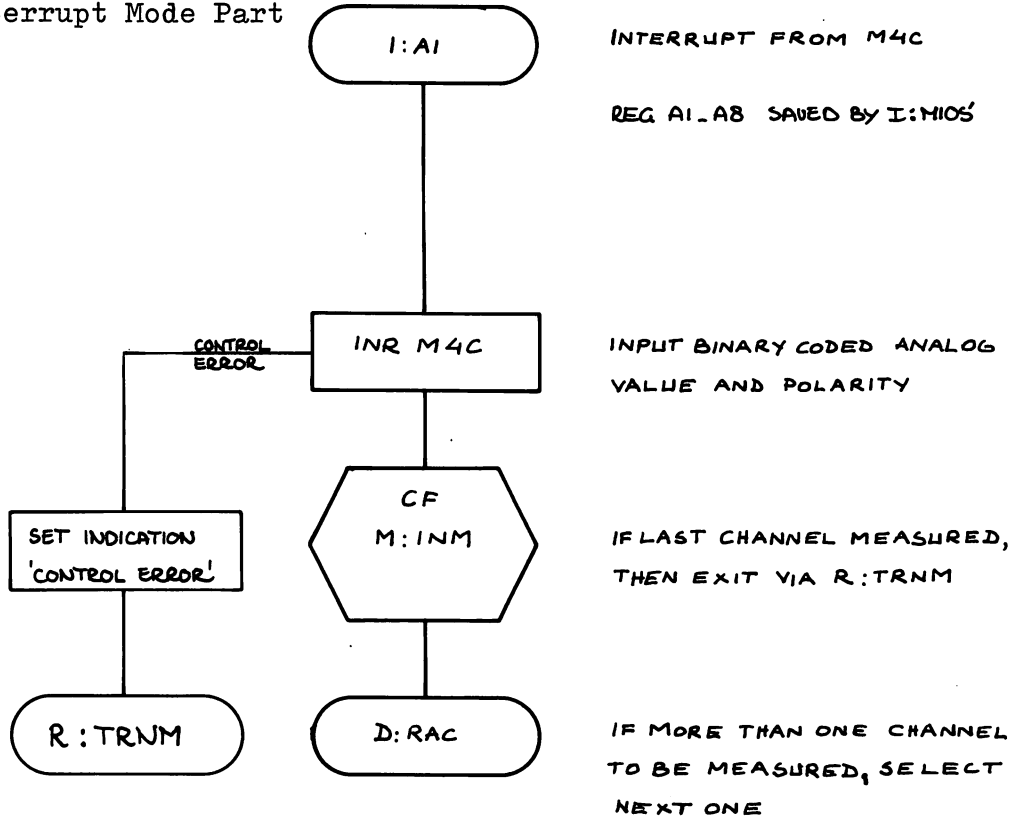

8. COMMON SUBROUTINE
MIOS INPUT

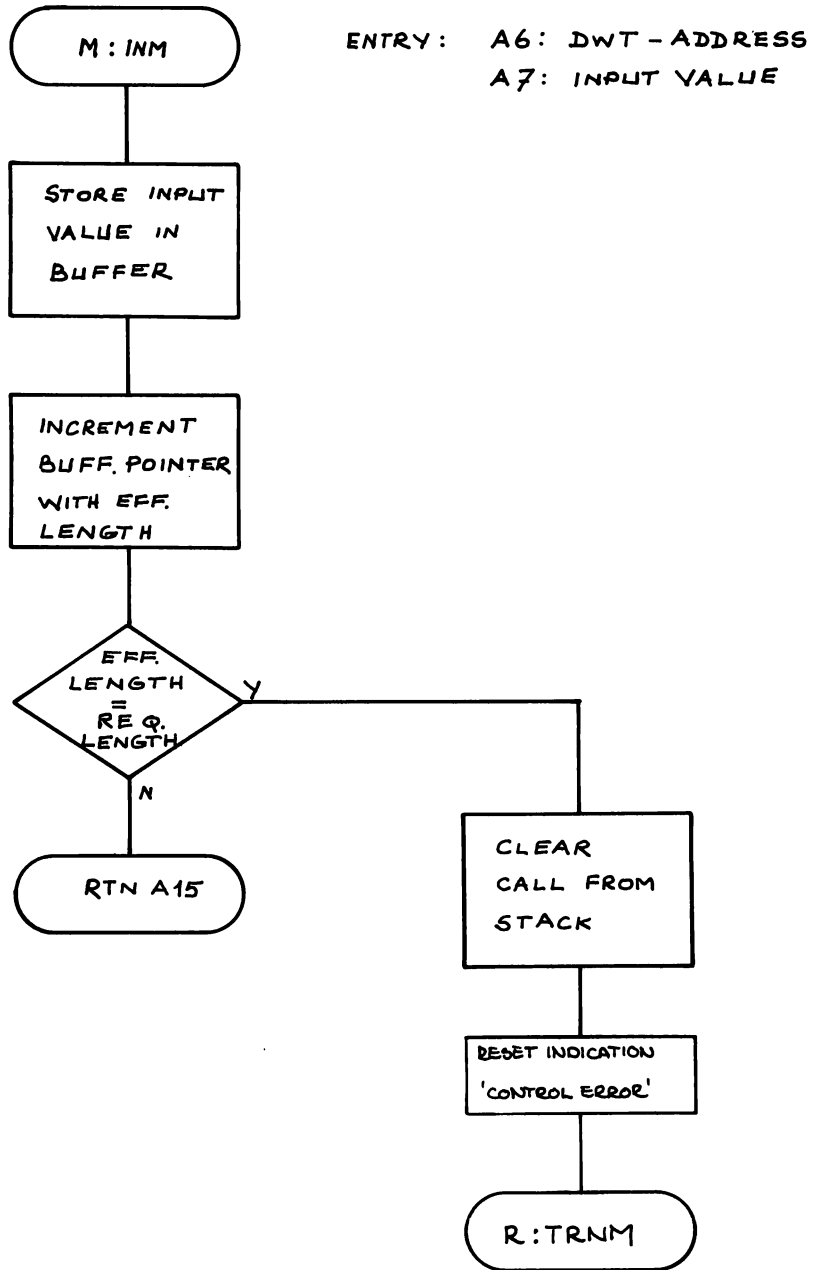

9. COMMON SUBROUTINE
MIOS OUTPUT

ENTRY: A6: DWT-ADDRESS
 A8: = 0 DATA IN BUFFER
 ≠ 0 DATA IN PARA-
 METER BLOCK

EXIT: A6: DWT-ADDRESS
 A7: OUTPUT DATA

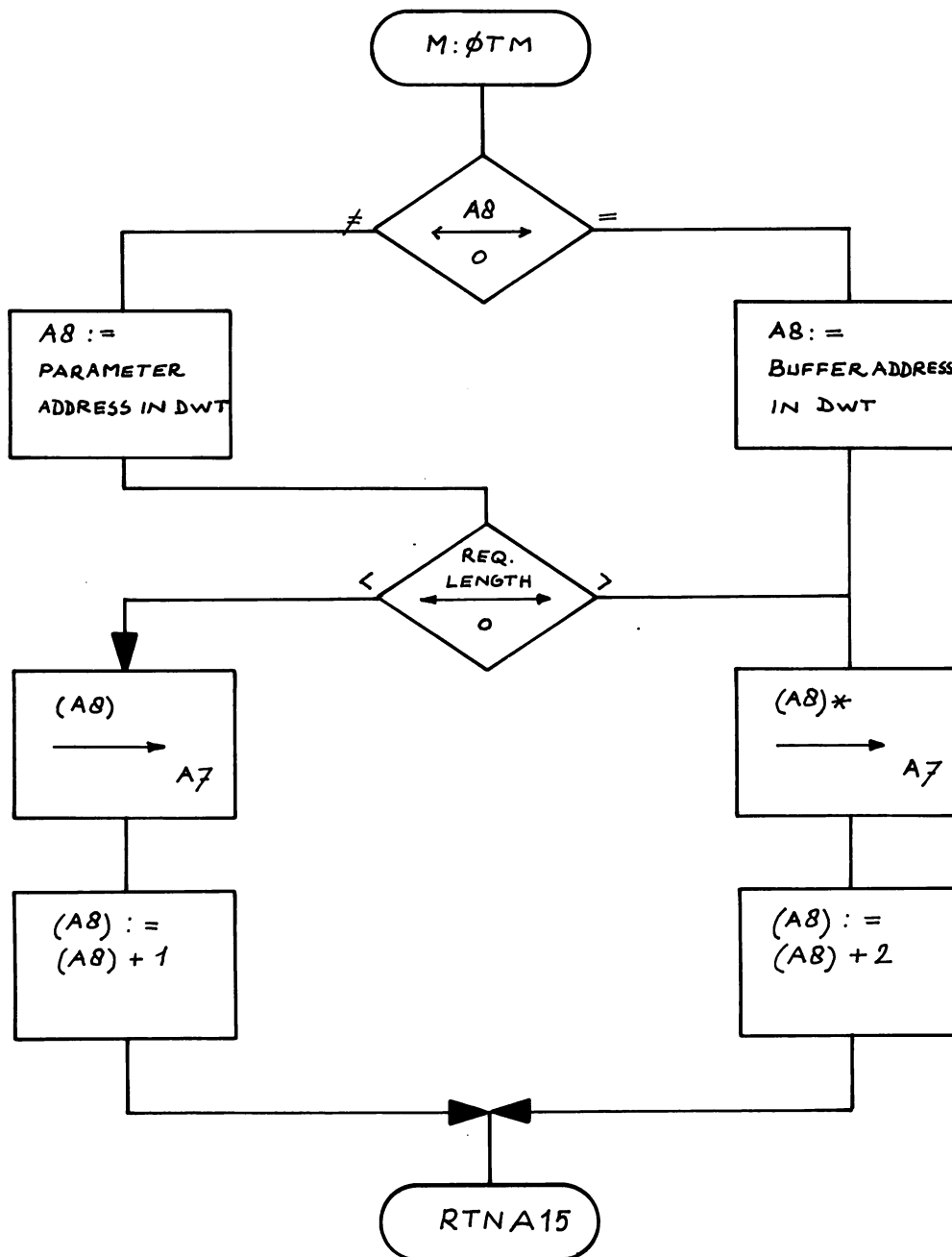

10. END OF MIOS HANDLING.

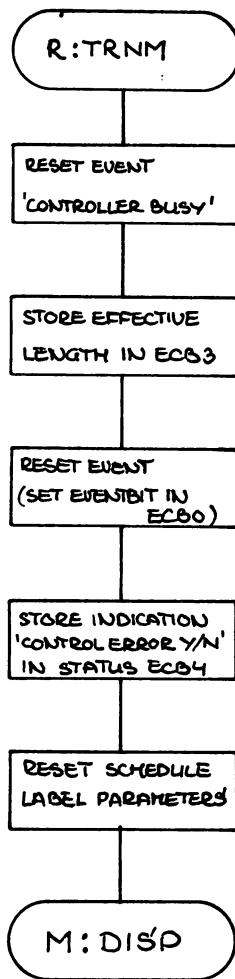

11. MIOS INTERRUPT DISCRIMINATOR.

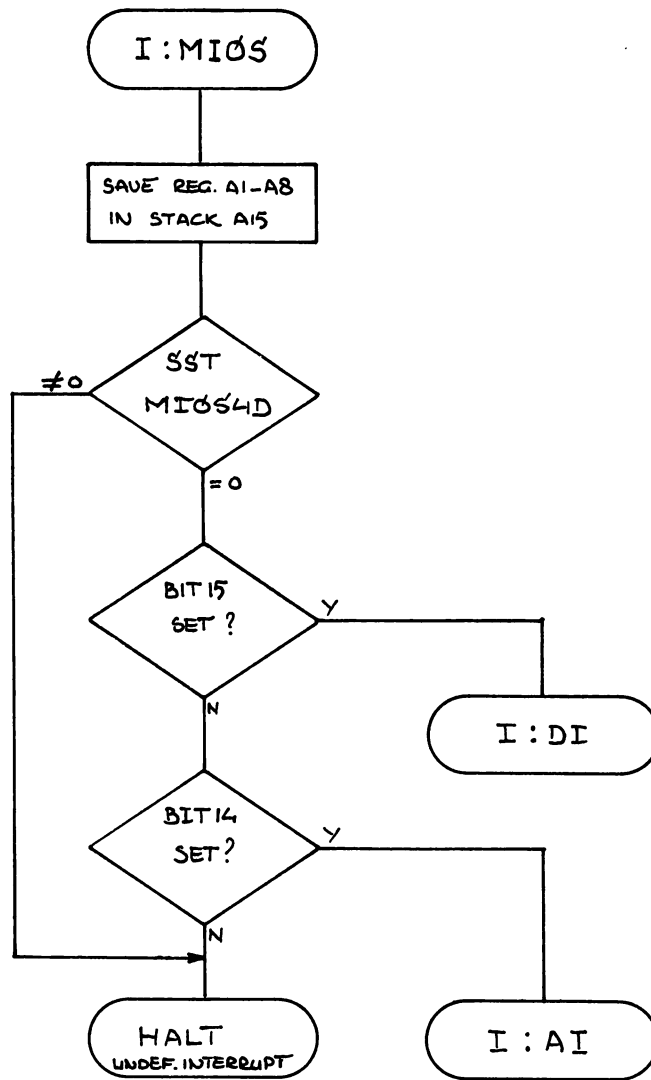

DRIVER MIOS 4C
ANALOG INPUTS
Programmed channel
external start ADC

ACTIVATION

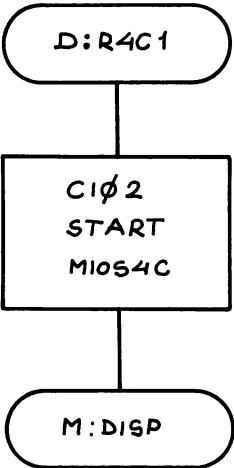

RETURN TO CALLER

INTERRUPT MODE

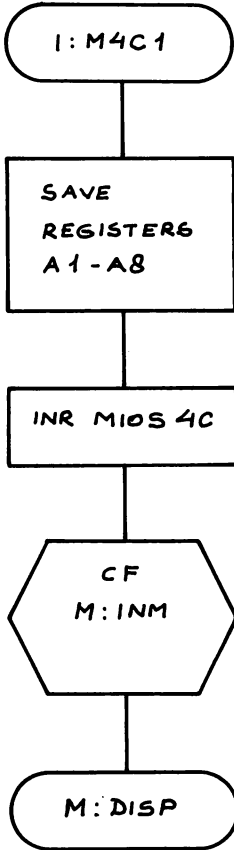

INPUT BINARY CODED ANALOG
VALUE + POLARITY

IF LAST CHANNEL MEASURED,
EXIT VIA R:TRNM

DRIVER MIOS 4C
ANALOG INPUTS
Programmed channel
internal start ADC

ACTIVATION

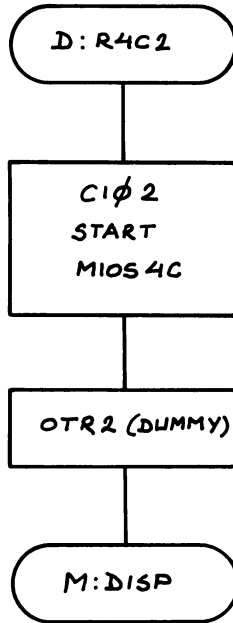

INTERRUPT MODE

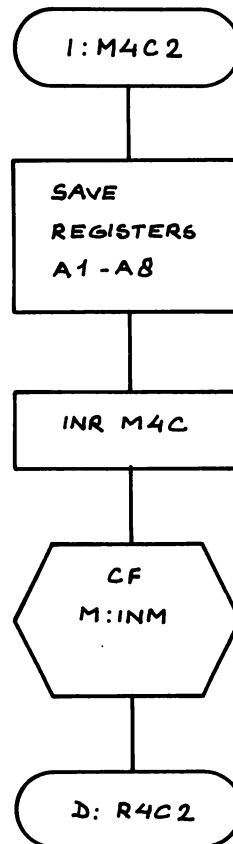

IF LAST CHANNEL MEASURED,
RETURN VIA R: TRNM

IF MORE THAN ONE CHANNEL
TO BE MEASURED, SELECT
NEXT ONE

DRIVER MIOS 4C
ANALOG INPUTS
DMC
external/internal start ADC

ACTIVATION

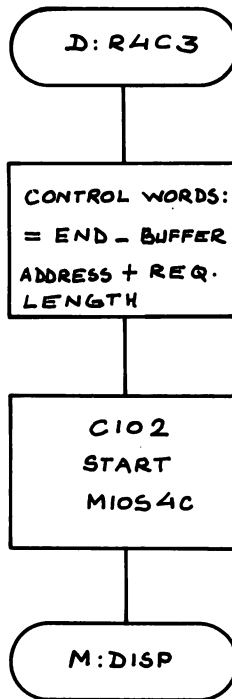

RETURN TO CALLER

INTERRUPT MODE

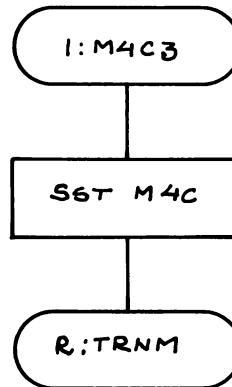

RESET INTERRUPT

SET EVENT FINISHED,
GO TO DISPATCHER-
TOP

DRIVER MIOS 4C
ANALOG OUTPUTS
Programmed channel

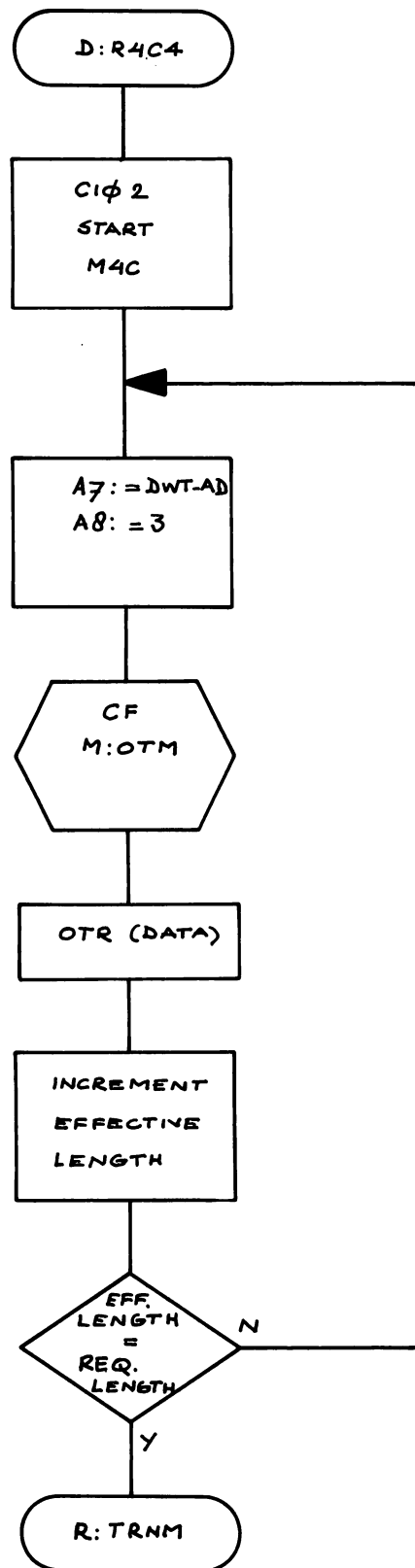

8. Testprogram MIOS-drivers.

This testprogram can be used for testing equipment fitted with MIOS-modules.

For user instructions see heading on listing.

```

00026      *
00027      * TFSTPROGRAM FOR MIOS-DRIVERS
00028      *
00029      * THE VARIOUS DRIVERS ARE ACTIVATED AFTER A DIALOGUE WITH THE OPERATOR,
00030      * TO BE STARTED BY OPERATORS PANEL INTERRUPT. IN THE DIALOGUE THE DE-
00031      * VICES AND I/O PARAMETERS ARE SPECIFIED. THE FOLLOWING DIALOGUE SEQUEN-
00032      * CES ARE POSSIBLE.
00033      *
00034      * QUESTIONMARK AND CHARACTERS GIVEN BEFORE THE COLUMN ARE OUTPUT BY THE
00035      * PROGRAM, THE OTHER ONES ARE TO BE TYPED IN BY THE OPERATOR. NUMBERS
00036      * SHALL BE GIVEN IN HEXADECIMAL CODE.
00037      *
00038      *-----
00039      *
00040      * ?DI,S
00041      * CHAN:5
00042      * NMB :3
00043      * DIGITAL INPUT OF CHANNELS 5, 6, 7.
00044      *
00045      *-----
00046      *
00047      * ?DI,N
00048      * CHAN:1,2,D
00049      * DIGITAL INPUT OF CHANNELS 1, 2, D.
00050      *
00051      *-----
00052      *
00053      * ?DO,S
00054      * CHAN:9
00055      * NMB :2
00056      * VAL :1234,5678
00057      * DIGITAL OUTPUT OF VALUE 1234 TO CHANNEL 9, VALUE 5678 TO CHANNEL A
00058      *
00059      *-----
00060      *

```

00061 * ?DO,N
00062 * CHAN:2,4,A,C
00063 * VAL :1834,012A,F120,2231
00064 * DIGITAL OUTPUT OF VALUES 1834, 012A FTC. TO RFSP. CHANNELS 2, 4 FTC.
00065 *
00066 *-----
00067 EJECT

```

00068 *
00069 * ?AV,S
00070 * CHAN:3048
00071 * NMB :8
00072 * ANALOG INPUT OF CHANNELS 48 - 4F WITH GAINFACTOR 3
00073 * CHANNELNO. INCLUDES BITSETTINGS FOR RANGE(GAIN) AND SAMPLETIME
00074 *
00075 *-----
00076 *
00077 * ?AV,N
00078 * CHAN:1048,1049,304A
00079 * ANALOG INPUT OF CHANNELS 48, 49, 4A WITH GAIN RESP. 1, 1, 3.
00080 * CHANNELNO. INCLUDES BITSETTINGS FOR RANGE(GAIN) AND SAMPLETIME
00081 *
00082 *-----
00083 *
00084 * FOR ANALOG INPUTS WITH ADC: USE COMMAND AA
00085 *
00086 * FOR ANALOG INPUTS WITH M4C: USE COMMAND AC
00087 *
00088 *-----
00089 *
00090 * ENTRY POINTS
00091 *
00092 *          ENTRY      STRTTS
00093 *          ENTRY      U:INIT
00094 *          ENTRY      I:CP
00095 *
00096 * EXTERNAL DECLARED LABELS
00097 *
00098 *          FXTRN      PCTTS          STATUSWORD PCT TSMIOS
00099 *          FXTRN      NAMTS          PROGRAMNAME  ,,
00100 *          EXTRN      M:DISP        ENTRY DISPATCHER
00101 *
00102 * EQUATES

```

```

00103
00104      0006      *
00105      0004      EFFFEB EQU      6
00106      0002      REQFCB EQU      4
00107      000A      BUFEBC FQU      2
00108
00109      *
00110      * DEVICE SPECIFICATIONS
00111      0000      0005      *
00112      0002      FCB DIA DATA      05      FILE CODF ASR-KEYBOARD
00113
00114      000A      *
00115      000C      ECBMIO RES      1      FILE CODE MIOS FUNCTIONS
00116
00117      *
00118      * COMMAND LINKAGE TABLE
00119      0016      4449      *
00120      0018      0214      R      T:COM DATA      'DI'
00121      001A      444F      DATA      DIMOD
00122      001C      021F      R      DATA      'DO'
00123      001E      4156      DATA      DOMOD
00124      0020      0250      R      DATA      'AV'
00125      0022      4141      DATA      AVMOD
00126      0024      0264      R      DATA      'AA'
00127      0026      4143      DATA      AAMOD
00128      0028      026F      R      DATA      'AC'
00129      002A      T:COME EQU      *
00130
00131      *
00132      * TEXT STRINGS
00133      002A      4348      *
00134      002C      414F      TXTC DATA      'CHAN:'
00134      0030      4E4D      TXTN DATA      'NMB : '
00134      0032      4220
00134      0034      3A20
    
```

```

00135 0036 5641          TXTV      DATA      'VAI : '
        0038 4C20
        003A 3A20
00136 003C 3F20          TXTQ      DATA      '? '
00137 003E 2020          SPA2      DATA      ' '
00138 0040 0D0A          CRLF      DATA      /0D0A
00139
00140          * BUFFERS
00141          *
00142 0042          INPBUF    RES          75
00143 00D8          OUTBUF    RES          25
00144 010A          PARBLK    RES          16          PARAMETER BLOCK FOR MIOS FUNCTIONS
00145          *
00146          * VARIABLES
00147          *
00148 012A          STADMD    RES          1          ADDR. STARTADDRESS MODULE
00149          *
00150          * INTERRUPT FROM CONTROL PANEL
00151          *
00152 012C  BC3F          I:CP      MSR          8,A15
00153 012E  20DF          RIT          /OF          RESET INTERRUPT LINE
00154 0130  2840          ENB
00155 0132  8720          LDKL          A7,NAMTS          A7:= ADDR NAME PROGRAM
        0134  0000          X
00156 0136  80A0          LDKL          A8,DUMBLK
        0138  0142          R
00157 013A  2804          LKM
00158 013C  000C          DATA          12          ACTIVATE TESTPROGRAM
00159 013E  8F20          ABL          M:DISP
        0140  0000          X
00160 0142          DUMBLK    RES          2
00161          * END OF I:CP
00162          *
00163          * USER INITIALISATION
00164          *
00165 0146  8F20          U:INIT    ABL          M:DISP          START SYSTEM DIRECTLY

```

00166	0148	0000	X			
00167				*		
00168	014A			* SAVE AREA TESTPROGRAM		
00169				RES 16		
00170				*		
00171				* THIS IS THE ENTRY FROM DISPATCHER		
00172				*		
00173	016A	80A0		* OUTPUT QUESTION MARK		
	016C	0000	R	STRTTS LDKL A8,FCBDIA		
00174	016E	0201				SET REQ. LENGTH
00175	0170	8320		LDK A2,1		SFT ADDR. '?'
	0172	003C	R	LDKL A3,XTQ		
00176	0174	F7A1		CF A15,SOUTT		OUTPUT QUESTION MARK
	0176	02EF	R			
00177				* INPUT OPERATOR COMMAND		
00178	0178	F7A1		CF A15,SINPL		INPUT A LINE
	017A	0302	R			
00179				* INVESTIGATE OPERATORS COMMAND		
00180	017C	8220		LDKL A2,T:COM		SFT POINTER TO TABLE START
	017F	0016	R			
00181	0180	8340		LD A3,INPBUF		FETCH COMMAND INPUT
	0182	0042	R			
00182	0184	EA20		NXPOS CWK A2,T:COME		TABLE END REACHED?
	0186	002A	R			
00183	0188	5820		RB(0) STRTTS		YES, INPUTCOMMAND NOT FOUND
00184	018A	EB28		CWR* A3,A2		COMPARE COMMAND WITH TABLE CONTENTS
00185	018C	8820		ABL(0) STRCMD		EQUAL, STORE COMMAND
	018F	0194	R			
00186	0190	1204		ADK A2,4		RUMP TO NEXT TABLE POS.
00187	0192	5F10		RB NXPOS		COMPARE WITH NEXT POSITION
00188	0194	1202		STRCMD ADK A2,2		SAVE ADDR. STARTADDRESS MODULF
00189	0196	8241		ST A2,STADMD		
	0198	012A	R			
00190	019A	F7A1		CF A15,SSEQF		SFT/RFSET SEQ.FLAG ACC. TO 4TH CHAR.
	019C	02DA	R			

00191				* ASK FOR CHANNELNO.		
00192	019F	0205		OUTCHL LDK	A2,5	
00193	01A0	8320		LDKL	A3, TXTC	
	01A2	002A	R			
00194	01A4	F7A1		CF	A15, SOUTT	OUTPUT 'CHAN:'
	01A6	02EF	R			
00195	01A8	F7A1		CF	A15, SINPL	INPUT A LINE
	01AA	0302	R			
00196	01AC	8620		LDKL	A6, FCBMIO	A6: FCB-ADDR. MIOS FUNCTIONS
	01AF	000A	R			
00197	01B0	8240		LD	A2, SEQFI	CHECK IF SEQUENTIAL INPUT WANTED
	01B2	02EC	R			
00198	01B4	8820		ABL(0)	NONSEQ	NON-SEQUENTIAL WANTED
	01B6	01E6	R			
00199				* SEQUENTIAL		
00200	01B8	8320		LDKL	A3, INPBUF	FETCH ADDR. OF CHARACTER CHANNFLNO.
	01BA	0042	R			
00201	01BC	F7A1		CF	A15, SSASH	CONVERT TO HEXA
	01BE	0324	R			
00202	01C0	8459		ST	A4, PARECB, A6	STORE TO PARAMETER IN ECB
	01C2	000A				
00203				* ASK FOR NUMBER OF CONSEQ. CHANNFLS		
00204	01C4	0205		OUTNMB LDK	A2,5	
00205	01C6	8320		LDKL	A3, TXTN	
	01C8	0030	R			
00206	01CA	F7A1		CF	A15, SOUTT	OUTPUT 'NMB :'
	01CC	02EF	R			
00207	01CE	F7A1		CF	A15, SINPL	INPUT A LINE
	01D0	0302	R			
00208	01D2	8320		LDKL	A3, INPBUF	FETCH ADDR. CHARACTER FOR NUMBFR
	01D4	0042	R			
00209	01D6	F7A1		CF	A15, SSASH	CONVERT TO HEXA
	01D8	0324	R			
00210	01DA	AC20		ORKL	A4, /8000	SFT F-BIT FOR SEQ. MODE
	01DC	8000				
00211	01DF	8459		ST	A4, REQECB, A6	STORE TO REQ.LENGTH IN ECB

00212	01E0	0004				
	01F2	8F60		ABI*	STADMD	GO TO SPECIFIC MODULE
	01E4	012A	R			
00213				*		
00214				* NON-SEQUENTIAL		
00215				*		
00216	01F6	8120		NONSEQ	LDKL A1,PARBLK	A1: POINTER TO PARAM.BLOCK
	01E8	010A	R			
00217	01EA	8159		ST	A1,PARECB,A6	SFT PAR.ADDR. IN FCB
	01EC	000A				
00218	01EE	8320		LDKL	A3,INPBUF	A3: POINTER TO CHAR'S OF CHANNELNO.
	01F0	0042	R			
00219				* CONVERT CHANNELNO.'S		
00220	01F2	F7A1		CVCHNX	CF A15,SSASH	CONVERT ASCII-CHAR. TO HFXA
	01F4	0324	R			
00221	01F6	8425		STR	A4,A1	STORE TO PARAMETERBLOCK
00222	01F8	020D		LDK	A2,/0D	SET ASCII-CODE FOR CR
00223	01FA	EA2D		CCR	A2,A3	IS CLOSING CHAR. A CR?
00224	01FC	5006		RF(0)	RQCALC	YFS
00225	01FE	1102		ADK	A1,2	NO, TALLY POINTER TO PAR.BLOCK
00226	0200	1301		ADK	A3,1	TALLY POINTER TO CHAR. BUF
00227	0202	5F12		RB	CVCHNX	CONVFT NEXT CHANNEL
00228				* CALCULATE REQ. LENGTH		
00229	0204	9920		RQCALC	SUKL A1,PARBLK	
	0206	010A	R			
00230	0208	3961		SRL	A1,1	
00231	020A	1101		ADK	A1,1	
00232	020C	8159		ST	A1,REQECB,A6	STDRF REQ. LENGTH IN FCB
	020F	0004				
00233	0210	8F60		ABI*	STADMD	GO TO SPECIFIC MODULE
	0212	012A	R			
00234				FJECT		

```

00235
00236
00237
00238 0214 0401
00239 0216 8441
      0218 000A R
00240 021A 8F20
      021C 0278 R
00241
00242
00243
00244
00245
00246 021F 0205
00247 0220 8320
      0222 0036 R
00248 0224 F7A1
      0226 02EF R
00249 0228 F7A1
      022A 0302 R
00250 022C 8120
      022F 0042 R
00251 0230 8320
      0232 0042 R
00252 0234 F7A1
      0236 0324 R
00253 0238 8425
00254 023A 020D
00255 023C FA2D
00256 023F 5006
00257 0240 1102
00258 0242 1301
00259 0244 5F12
00260
00261 0246 0402

```

```

*
* DIGITAL INPUT MODULE
*
DIMOD   LDK       A4,1           SFT MIOS CODE DI
        ST        A4,FCBMIO      IN FCB WORD 0
        ABL       PERFMI         PERFORM MIOS FUNCTION
*
* DIGITAL OUTPUT MODULE
*
* ASK FOR VALUE
*
DOMOD   LDK       A2,5           BASIC WRITE
        LDKL      A3,XTXV
        CF        A15,SOUTT      OUTPUT 'VAL : '
        CF        A15,SINPL      INPUT A LINE
        LDKL      A1,INPBUF      SET POINTER TO OUTPUTBUFFER
        LDKL      A3,INPBUF      SFT POINTER TO BUF WITH ASCII-VALUES
DOVLNX  CF        A15,SSASH      CONVERT VALUE TO HEXA
        STR       A4,A1          STORF TO OUTPUTBUFFER
        LDK       A2,70D         SFT ASCII-CODE FOR 'CR'
        CCR       A2,A3          IS CLOSING CHAR. A CR?
        RF(0)     PERFDO         YES, PERFORM DO
        ADK       A1,2           NO, TALLY POINTER TO OUTPUTBUFFER
        ADK       A3,1           TALLY POINTER TO CHARACTER BUFFER
        RB        DOVLNX        CONVERT NEXT ASCII-VALUE
* PERFORM DIGITAL OUTPUT
PERFDO  LDK       A4,2           SET MIOS CODE DO

```

00262 0248 8441
 024A 000A R
 00263 024C 8F20
 024F 0278 R
 00264

ST A4,FCBMIO IN WORD 0 ECB
 ABL PFRFMI PERFORM MIOS I/O REQUEST
 EJECT

```

00265      *
00266      * ANALOG INPUT DVM MODULE
00267      *
00268 0250 0403      AVMOD   LDK       A4,3           SFT MIOS CODE AI/DVM
00269 0252 8441      ST       A4,FCBMIO        IN WORD 0 OF ECB
           0254 000A   R
00270 0256 8458      LD       A4,REQECB,A6     MULTIPLY REQ.LENGTH BY 2
           0258 0004
00271 025A 3C41      SLL      A4,1
00272 025C 8459      ST       A4,REQECB,A6
           025F 0004
00273 0260 8F20      ABL      PFRFMI          PERFORM MIOS I/O REQUEST
           0262 0278   R
00274      *
00275      * ANALOG INPUT ADC MODULE
00276      *
00277 0264 0404      AAMOD   LDK       A4,4           SFT MIOS CODE AI/ADC
00278 0266 8441      ST       A4,FCBMIO        IN WRD 0 ECR
           0268 000A   R
00279 026A 8F20      ABL      PFRFMI          PERFORM MIOS I/O REQUEST
           026C 0278   R
00280      *
00281      * ANALOG INPUT M4C MODULE
00282      *
00283 026E 0405      ACMOD   LDK       A4,5           SFT MIOS CODF AI/M4C
00284 0270 8441      ST       A4,FCBMIO        IN WORD 0 OF ECB
           0272 000A   R
00285 0274 8F20      ABL      PFRFMI          PERFORM MIOS I/O REQUEST
           0276 0278   R
00286      EJECT

```

```

00287
00288
00289
00290 0278 8220
00291 027A 0042 R
00291 027C 8259
00291 027F 0002
00292 0280 8098
00293 0282 2804
00294 0284 0013
00295 0286 2804
00296 0288 0002
00297
00298
00299
00300
00301
00302
00303 028A 8558
00303 028C 0004
00304 028F A520
00304 0290 7FFF
00305 0292 8620
00305 0294 0042 R
00306 0296 81A0
00306 0298 0008
00307 029A 8318
00308 029C 8220
00308 029F 00D8 R
00309 02A0 F7A1
00309 02A2 035F R
00310 02A4 8140
00310 02A6 003F R
00311 02A8 8129
00312 02AA 1302

```

*
* MIOS I/O REQUEST
*
PERFMI LDKL A2,INPBUF
ST A2,BUFECB,A6 SFT INPUT BUFFER ADDR.
LDR A8,A6 A8: FCB-ADDR.
LKM
DATA 19 MIOS I/O REQUEST
LKM
DATA 2 WAIT FOR INPUT FINISHED

*
* FOR ALL MIOS I/O REQUESTS VALUES ARE PRINTED
* ALSO FOR DO, SO THAT A CHECK IS AVAILABLE ON
* VALUES INPUT BY THE OPERATOR.
*
* PRINT VALUES
PRVAL LD A5,REQECB,A6 GFT REQ, LENGTH
ANKL A5,/7FFF MASK OUT NO. OF CHANNELS
LDKL A6,INPBUF A6:= ADDR. VALUE TO CONVERT
NXLINE LDKL A9,8 A9: MAX NO. OF VALUES ON ONE LINE
LDR A3,A6 A3:= POINTER TO INPUTBUFFER
LDKL A2,OUTBUF A2: ADDR CHAR. BUFFER
NXVAL CF A15,S4HAS CONVERT VALUE TO ASCII
LD A1,SPA2 STORE TWO SPACES FOR LAY-OUT
STR A1,A2 IN CHARACTER BUFFER
ADK A3,2 INCR. VALUE POINTER

00313	02AC	1202		ADK	A2,2	INCR. BUFFER POINTER
00314	02AF	1D01		SUK	A5,1	ALL VALUES PRINTED?
00315	02B0	5006		RF(0)	OUTVAL	YES
00316	02B2	99A0		SUKL	A9,1	CHECK LINE FINISHED
	02B4	0001				
00317	02B6	5918		RB(1)	NXVAL	NO, NEXT VALUE
00318				* LINE FINISHED		
00319	02B8	8140		OUTVAL	LD	STORE CR/LF
	02BA	0040	R			
00320	02BC	8129		STR	A1,A2	IN CHAR. BUFFER
00321	02BE	1202		ADK	A2,2	CALCULATE REQ, LENGTH OUTPUTP
00322	02C0	9A20		SUKL	A2,OUTBUF	
	02C2	00D8	R			
00323	02C4	860C		LDR	A6,A3	SAVE A3
00324	02C6	8320		LDKL	A3,OUTBUF	SET CHAR. BUFFER ADDR.
	02C8	00D8	R			
00325	02CA	80A0		LDKL	A8,FCBDIA	SET ECB-ADDR.
	02CC	0000	R			
00326	02CF	F7A1		CF	A15,SOUTT	OUTPUT A LINE
	02D0	02EF	R			
00327	02D2	8514		LDR	A5,A5	CHECK ALL VALUES PRINTED
00328	02D4	5940		RB(1)	NXLINE	NO NEXT LINE
00329				* PRINT FINISHED		
00330	02D6	2804		LKM		EXIT TEST PROGRAM, RESTART BY OP. PANEL I
00331	02D8	0003		DATA	3	
00332				EJECT		

```

00333      *
00334      * SUBROUTINE SET/RESET SEQUENTIAL FLAG
00335      *
00336  02DA  0301      SSEQF   LDK      A3,1           SET SEQ, FLAG
00337  02DC  0253      LDK      A2,/53          A2: 'S'
00338  02DE  EA41      CC        A2,INBUF+3      COMPARE WITH 4TH CHAR. INPUT
          02E0  0045  R
00339  02E2  500?      RF(0)   SAVFFL          IF NOT 'S' THEN
00340  02E4  0300      LDK      A3,0           RESFT SEQ. FLAG
00341  02E6  8341      SAVFFL  ST        A3,SEQFL  SAVF FLAG
          02E8  02EC  R
00342  02FA  F03F      RTN      A15           RETURN TO CALLER
00343  02FC      SEQFL  RES        1           SEQUENTIAL FLAG
00344      * END OF ROUTINE SSEQF
00345      EJECT

```

```

00346      *
00347      * SUBROUTINE OUTPUT TEXT
00348      *
00349      * ENTRY: A2: REQ.LENGTH
00350      *          A3: ADDR. TFXTBUFFER
00351      *          A8: ADDR. ECB
00352      *
00353 02FF 8243      SOUTT      ST          A2,REQECB,A8          SET REQ, LENGTH
          02F0 0004
00354 02F2 8343          ST          A3,BUFECB,A8          SET ADDR. BUFFER
          02F4 0002
00355 02F6 0705          LDK          A7,5          BASIC WRITE
00356 02F8 2804          LKM
          DATA          1          I/O REQUEST
00357 02FA 0001          LKM
00358 02FC 2804          DATA          2          WAIT FOR OUTPUT FINISHED
00359 02FF 0002          RTN          A15          RETURN TO CALLER
00360 0300 F03F
00361      * END OF ROUTINE SOUTT
00362      EJECT

```

```

00363
00364      *
00365      * SUBROUTINE INPUT A LINE
00366      *
00366      0302  0296      SINPL   LDK      A2,150      SET REG, LENGTH
00367      0304  8243      ST       A2,REQECB,A8    MAY NOY EXCFED 75 LOCATIONS
00368      0306  0004
00368      0308  8220      LDKL    A2,INPBUF    SET BUFFERADDR.
00369      030A  0042      R
00369      030C  8243      ST       A2,BUFECB,A8
00369      030F  0002
00370      0310  0702      LDK      A7,2      STANDARD READ
00371      0312  2804      LKM
00371      0312  2804      LKM      I/O REQUEST
00372      0314  0001      DATA   1
00373      0316  2804      LKM
00373      0316  2804      LKM      WAIT ON INPUT FINISHED
00374      0318  0002      DATA   2
00375      031A  9242      AD       A2,FFFECEB,A8  MAKE LAST CHAR. INPUT = CR
00375      031C  0006
00376      031F  070D      LDK      A7,/D
00377      0320  E729      SCR     A7,A2      STORF TO INPUTBUFFER
00378      0322  F03F      RTN     A15
00379      * END OF ROUTINE SINPL
00380      EJECT
    
```

```

00381          *
00382          * SUBROUTINE CONVERT STRING OF ASCII-CHAR'S TO HEXA
00383          * THIS STRING SHALL BE CLOSED BY ANY CHARACTER NOT
00384          * BEING A HEXADECIMAL CONSTANT
00385          *
00386          * ENTRY: A3: STARTADDRESS STRING
00387          *
00388          * EXIT : A3: ADDRESS OF CLOSING CHARACTER
00389          *         A4: HEXADECIMAL VALUF
00390          *
00391 0324 0400  SSASH  LDK      A4,0          SET INITALE HEXA VALUE
00392 0326 F7A1  CVNXA  CF      A15,SIASH    CONVERT 1 ASCII
00393 0328 0338  R
00393 032A 8208  LDR      A2,A2          SET CONDITION A2
00394 032C 5602  RF(6)   ADTVAL      IF CHAR. IS HEXADFC.CONSTANT, THEN ADD TO
00395 032E F03F  RTN      A15           FLSE RETURN TO CALLER; A4: CONVERTFD VALU
00396 0330 3C44  ADTVAL  SLL      A4,4    SHIFT PRFVIOUS HEXADECIMAL
00397 0332 9408  ADR      A4,A2        ADD JUST CONVERTED HEXADFC.
00398 0334 1301  ADK      A3,1         TALLY POINTER TO NEXT CHAR.
00399 0336 5F12  RB      CVNXA        GO AND COVERT NEXT ASCII
00400          * END OF ROUTINE SSASH
00401          EJECT

```

```

00402      *
00403      * SUBROUTINE CONVERT 1 ASCII CHAR. TO HEXADFCIMAL
00404      *
00405      * ENTRY: A3: ADDR. ASCII-CHAR.
00406      *
00407      * EXIT: A2: HEXADECIMAL VALUE
00408      *       IF A2<0: CHAR. IS NOT A HEXADFCIMAL CONSTANT
00409      *
00410 0338 F22C      SLASH   LCR       A2,A3      FFTCH CHAR.
00411 033A 22FF      ANK      A2,/FF     MASK OUT LEAST SIGN 8 BITS
00412 033C EA20      CWK      A2,'0'     COMPARE TO LOWEST POSSIBLE CYPHER
        033F 0030
00413 0340 5218      RF(2)    ERRCHR     ILLEGAL CHAR.
00414 0342 EA20      CWK      A2,'9'     COMPARE TO HIGHEST POSSIBLE CYPHER
        0344 0039
00415 0346 550F      RF(5)    CORCHR     CORRECT CHAR.
00416 0348 EA20      CWK      A2,'A'     COMPARE TO LOWEST POSSIBLE CHARACTER
        034A 0041
00417 034C 520C      RF(2)    ERRCHR     ILLEGAL CHAR.
00418 034F EA20      CWK      A2,'F'     COMPARE TO HIGHEST POSSIBLE CHARACTER
        0350 0046
00419 0352 5106      RF(1)    ERRCHR     ILLFGAL CHARACTER
00420 0354 1209      ADK      A2,9      CONVERT CHARACTER TO HEXA
00421 0356 220F      CORCHR  ANK      A2,/F     MASK OUT HEXA
00422 0358 F03F      EXIT     RTN      A15
00423 035A FA08      FRRCHR  C1R      A2,A2     SFT INDICATION ILIFGAL CHAR.
00424 035C 5F06      RB      RB      EXIT
00425      * END OF ROUTINE SLASH
00426      EJECT

```

```

00427      *
00428      * SUBROUTINE CONVERT 4 HEXA'S TO ASCII
00429      *
00430      * ENTRY: A3: ADDRESS OF VALUE TO CONVERT
00431      *          A2: ADDRESS OF BUFFER TO STORE ASCII-CODE
00432      *
00433      * USED : A1, A2, A4, A7
00434      *
00435 035F 0104      S4HAS   LDK       A1,4           INITIATE LOOP FOR 4 HEXA'S
00436 0360 842C      LDR*     A4,A3           GET VALUE
00437 0362 3CC4      SPCLP   SLC       A4,4           SHIFT HEXA TO LEAST SIGN POS.
00438 0364 8710      LDR     A7,A4
00439 0366 270F      ANK     A7,/F           MASK OUT HEXA
00440 0368 E75C      LC       A7,HEXVAL,A7       FETCH ASCII-CODE
00440 036A 0376      R
00441 036C E729      SCR     A7,A2           STORE CHARACTER TO BUFFER
00442 036F 1201      ADK     A2,1           INCR. BUFPOINTER
00443 0370 1901      SUK     A1,1           CHECK IF 4 HEXA'S DONE
00444 0372 5912      RB(1)  SPCIP          NO, DO NEXT ONE
00445 0374 F03F      RTN     A15          RETURN TO CALLER
00446 0376 3031      HEXVAL  DATA      '0123456789ABCDEF'
00446 0378 3233
00446 037A 3435
00446 037C 3637
00446 037F 3839
00446 0380 4142
00446 0382 4344
00446 0384 4546
00447      * END OF TSMIOS
00448      0000      END

```

P855M/P860M MIOS Drivers

5122 991 12341

Name _____

Company _____

Address _____

Telephone number _____ Ext. _____

Comments or suggestions